

# Radio-Electronics®

FOR MEN WITH IDEAS IN ELECTRONICS

## New Way To Select Replacement Transistors

## Microwave Ovens—A Look Inside

491168 PUL 5809L090 JUL79 3 A  
02 4  
T POULIN  
5809 LONDON RD  
DULUTH MN 55804

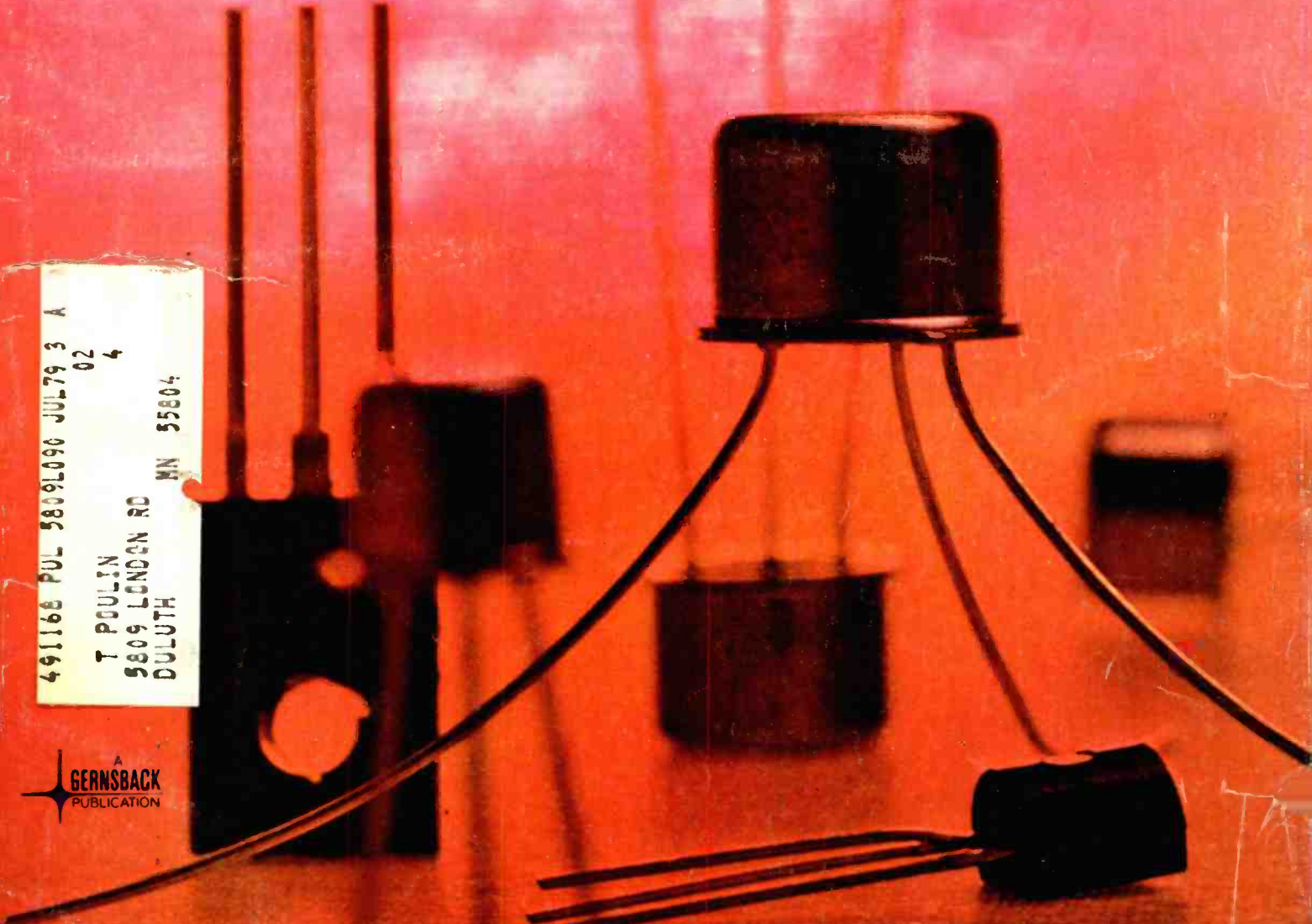

**BUILD: Low-Cost IC Audio Generator  
Darkroom Temperature Monitor • Pocket Pimper**

**Designing Hi-Fi Amplifiers**



# 5 new RCA VOM's\* Priced from \$9.95\*\* to \$48.00\*\*



\*Complete with test leads,  
batteries and full  
RCA warranty  
(12 months parts and labor).

Input resistances  
from 2000 to 100,000  
ohms per volt.

\*\*Optional Distributor Resale Price



RCA | Electronic Components | Harrison, New Jersey 07029

If You Plan To **STAY IN** and **MOVE AHEAD IN** Electronics

# UPGRADE YOUR KNOWLEDGE and your paycheck

Yes, *upgrading* is the name of the game. More knowledge to supplement your experience brings more pay and greater job security. And to hold an *accredited degree* from Grantham School of Engineering is another important *plus*, which you can "chalk up" for your side while you are upgrading your electronics knowledge at the college level.

## Are You Ready For an Employment Cutback?

Don't let an *employment cutback* get your job. Those who have *real* knowledge and ability are the ones who **STAY IN** their jobs when the unemployment axe begins to fall. And the stronger your knowledge and ability, the more likely you are to *stay in* and also to **MOVE AHEAD** to higher and more profitable levels of employment.

Grantham School of Engineering knows what it takes for an electronics technician to advance. Our entire program is devoted to preparing technicians to upgrade, step-by-step, to better positions. You can advance from technician to engineering technician, and then to electronics engineer. Upon completion of our educational program you are awarded the *Degree of Associate in Science in Electronics Engineering* — the ASEE Degree.

This *accredited* ASEE Degree program includes a review of basic electronic circuits and systems, a thorough coverage of applied engineering mathematics (including algebra, trigonometry, and calculus), classical and modern physics, technical writing, computer science, electrical networks, and semiconductor circuit analysis and design.

## Not For Beginners

The Grantham educational program in electronics engineering is *not for beginners*. Every point is explained just as carefully as if you were a beginner, but this program is designed, written, and taught *for and to* experienced technicians; beginners are not accepted for enrollment. As a technician, you already know the "hardware" side of electronics, and you can upgrade from technician to engineering technician, and then to engineer, while you continue your employment in electronics.

## Study By Correspondence, At Home

The Grantham ASEE Degree program is offered entirely by correspondence except for the final two weeks. After completing 390 correspondence lessons, you then go to School for a two-week *graduation seminar*, at which time you are awarded your degree.

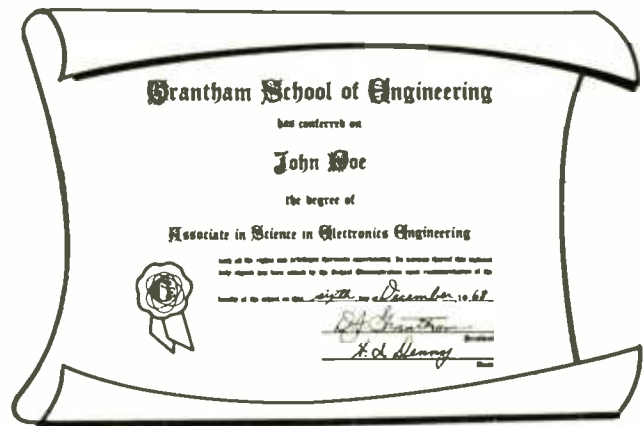

## Accreditation and G. I. Bill Approval

Grantham School of Engineering is *accredited* by the Accrediting Commission of the National Home Study, is *approved* under the G. I. Bill, and is *authorized* under the laws of the State of California to grant academic degrees.

## Find out how you can advance in electronics

- Mail the coupon below for our free Bulletin ●

**Grantham School of Engineering** RE-2-71  
1505 N. Western Ave., Hollywood, Calif. 90027

Gentlemen:

Please send me your free Bulletin which gives complete details on the Grantham educational program leading to the Associate Degree in Electronics Engineering. I understand no salesman will call.

Name \_\_\_\_\_

Address \_\_\_\_\_

City \_\_\_\_\_ State \_\_\_\_\_ Zip \_\_\_\_\_

I have been in electronics for \_\_\_\_\_ years.

## Grantham School of Engineering

• Established in 1951 •

1505 N. Western Ave.  
Hollywood, Calif. 90027

Telephone:  
(213) 469-7878



• Circle 19 on reader service card

Circle 1 on reader service card



# NEW & TIMELY

Volume 42 Number 2

RADIO-ELECTRONICS . . . FOR MEN WITH IDEAS IN ELECTRONICS

February 1971

## TALKING COMPUTER IN THE LAB



MURRAY HILL, N.J.—“The party you have just called has been assigned a new number. The number is . . .” Sound familiar? These and other helpful words may one day be spoken to Bell System customers by a “talking” computer.

Recent work by three Bell Laboratories scientists makes it practical to store large vocabularies of synthetic speech in talking computers.

L. R. Rabiner, R. W. Schafer and J. L. Flanagan have devised a method of producing computer-spoken synthetic speech using about one-fiftieth the amount of digital information normally required. The method includes the techniques of speech analysis, concatenation (linking words together), and synthesis and is a research step toward providing computers with a practical means for supplying answers by voice.

According to J. L. Flanagan, head of Bell's Acoustic Research Department, “Individual words spoken by a human are analysed, converted into numerical information, and stored in a computer. Pre-programmed instructions tell the machine to link the stored data into the numerical equivalent of sentences,

and then convert this digital information into synthetic speech.”

When computers are able to talk as easily as they can now print or display information, they may provide a whole new range of communications services. A user, desiring information from a computer library, might call the computer from home and have the machine speak the information over his telephone. Numerical data, entered from a telephone, could be processed by stored programs and the result reported verbally. Similarly, talking computers might supply spoken weather reports, provide inventory accounting, give verbal status reports from aircraft and space vehicles, or provide information to help people complete telephone calls that reach disconnected or changed numbers through the Bell System's automatic intercept service.

To provide computers with a store of words they can use for talking, human speech must be broken down into basic elements and converted into digital information a machine can understand. These basic elements describe the natural resonances produced by the vocal

tract when people talk. Determining these elements and converting them into computer language is accomplished through an analysis of real speech. The resulting information describes speech sounds that require only about one fiftieth of the digital storage capacity that is presently used to record natural speech.

To produce a sentence, the stored elements for individual words and phrases are consolidated or linked together by the computer. The final step in the process, digital synthesis, converts the data into intelligible sound waves that can be fed to an ordinary loudspeaker or transmitted over a con-



ventional telephone system.

Different sounding speech can be produced by telling the computer to lengthen or shorten words; insert pauses; and superimpose pitch variations for the sentence.

One such system has just been put into use in Long Island, N. Y. It handles inquiries about disconnected or changed numbers. ★

### MICROWAVE OVENS

They're new, they're electronic, and they're on page 68 of this issue of RADIO-ELECTRONICS.

See how they work, how to keep them working, and a brief on microwave safety problems.

## SHOOT THE SUN BY X-RAYS

PITTSBURGH, PA.—A TV camera, with a SEC (Secondary Electron Conduction) tube similar to the one our astronauts used to send moon pictures back to earth, is being used to test an x-ray telescope that will fly on the Skylab orbiting satellite to be launched in 1972.

The imaging x-ray telescope, to be used to obtain high-resolution photographs of the sun in x-rays, is being designed, built, and tested by the American Science and Engineering Corporation of Cambridge, Mass. When in actual use in space, the telescope will image soft x-rays from the sun onto photographic film.

In the laboratory long exposures are required because of the weakness of laboratory x-ray sources. To conduct tests with the telescope, exposure times have been shortened by substituting the SEC camera for the film. Images are portrayed on a TV monitor and then photographed with Polaroid film.

Since soft x-rays don't travel very far in our atmosphere without being absorbed, space conditions are simulated using a vacuum



chamber. In the chamber the Westinghouse SEC camera is coupled by the laboratory's own optical relay with an x-ray image intensifier.

The test setup enables the lab to better evaluate the properties of the x-ray telescope and further perfect it prior to the 1972 launch of Skylab. (continued on page 6)

# Radio-Electronics.

FOR MEN WITH IDEAS IN ELECTRONICS

February 1971 • Over 60 Years of Electronics Publishing

## SPECIAL FEATURES

- Replacement Transistors** . . . . . **33** . . . . . Jack Darr  
*New way to select the right one fast*
- What's A Frequency Synthesizer** . . . . . **50** . . . . . Larry Allen  
*How to make an accurate radio transmitter*
- Microwave Ovens** . . . . . **68** . . . . . Larry Steckler  
*A brand new way to cook with electronics*

## TELEVISION

- In The Shop** . . . . . **26** . . . . . Jack Darr  
*Checking the chip*
- Kwik-Fix Troubleshooting Charts** . . . . . **59** . . . . . Forest Belt  
*Transistor video amplifiers*
- Service Clinic** . . . . . **82** . . . . . Jack Darr  
*Reader questions answered by the Service Editor*

## BUILD ONE OF THESE

- One-IC Audio Generator** . . . . . **37** . . . . . R. D. Crawford  
*Low-cost high-quality unit is easy to build*
- Darkroom Temperature Monitor** . . . . . **40** James A. Gupton, Jr.  
*Use a thermistor and get it right*
- Pocket-Pipper** . . . . . **46** . . . . . Tom Annes  
*Portable pulse generator fits the palm of your hand*

## STEREO—HI-FI—AUDIO

- Solid-State Amplifier Design** . . . . . **64** . . . . . Mannie Horowitz  
*Part III: Transistors in audio circuits*

## GENERAL ELECTRONICS

- Looking Ahead** . . . . . **4** . . . . . David Lachenbruch  
*Current happenings with future overtones*
- Engineers & Doctors** . . . . . **39** Dr. P. Reichert, M. D.  
*A new kind of partnership centered around electronics*
- The Laser** . . . . . **43** . . . . . Bureau of Radiological Health  
*Part II: Operation and applications today*
- Resistor Polygons** . . . . . **48** . . . . . J. T. Heydt  
*New way to build a substitution box*
- Using Operator "j"** . . . . . **49** . . . . . John R. Collins  
*A very important letter of the alphabet*
- Patent Talk** . . . . . **53** . . . . . Arthur S. Cookfair  
*Some words about getting a patent*
- Logic Laboratory** . . . . . **87** . . . . .  
*Part III: Complete parts list and source of suppliers*

## DEPARTMENTS

- Coming Next Month** . . . . . **83**      **New & Timely** . . . . . **2**
- Correspondence** . . . . . **22**      **New Literature** . . . . . **77**
- New Products** . . . . . **72**



**Microwave ovens are here now:** perhaps in your kitchen tomorrow. Do you know how they work, their hazards, maintenance techniques? . . . see page 68



**Low-Cost audio generator** is built around one IC, yet offers extremely low-distortion output. You'll want one for your bench. Get complete details.

. . . see page 37

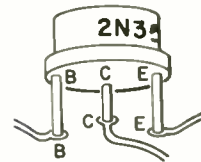

ORIGINAL

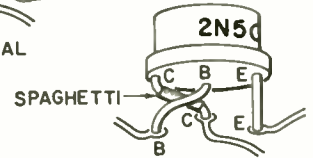

REPLACEMENT

**Replacement transistors are always a problem.** Here's a new method for finding the "right" replacement with a minimum of fuss. . . . see page 33

- Noteworthy Circuits** . . . . . **86**
- Try This One** . . . . . **85**

RADIO-ELECTRONICS, Feb. 1971, Vol. 42, No. 2  
 Published monthly by Gernsback Publications, Inc., at 200 Park Avenue South, New York, New York 10003.  
 Editorial, Advertising, and Executive offices: 200 Park Ave. S., New York, N.Y. 10003. **Subscription Service: Boulder, Colo. 80302.**  
 Second-class postage paid at New York City and additional mailing office. Printed in U.S.A. One-year subscription rate: U.S.  
 and possessions, Canada, \$7. Pan-American countries, \$8. Other countries, \$8.50. Single copies 60¢.

©1971 by Gernsback Publications, Inc. All rights reserved.

POSTMASTER: Notices of underdelivered copies (Form 3579) to Boulder, Colo. 80302.



Radio-Electronics is indexed in  
*Applied Science & Technology  
 Index (formerly Industrial  
 Arts Index)*



# LOOKING AHEAD

Volume 42 Number 2

RADIO-ELECTRONICS . . . FOR MEN WITH IDEAS IN ELECTRONICS

February 1971

by **DAVID LACHENBRUCH**  
CONTRIBUTING EDITOR

## Great leap forward

The electronics-communications story of the year may well be a loosely-knit organization which goes under the initials "BCN" and is shrouded in self-imposed secrecy. BCN stands for Broadband Communications Networks, and to the best of our knowledge, at our presstime, it had received no mention in any general-circulation publication.

BCN was mentioned briefly in *Looking Ahead* last month, and the more information that comes to light the more intriguing the whole idea seems. BCN basically is an effort to speed up the timetable of the future of electronic communication into and out of the home, businesses and educational institutions. Its members quite casually admit that nothing at all may come of it. But, on the other hand, BCN could give birth to a new giant in the field of communications of the future.

BCN's basic premise is that the communications and electronics wonders of the future can be turned into reality much sooner if major corporations pool money and know-how and work together, than if everybody goes off in a different direction. The list of member companies in BCN is still—officially—a closely guarded secret, but there are understood to be at least 20 of them, including many of America's top firms in technology and information.

It is known that the members include IBM and Honeywell in the data-processing field; Magnavox, Motorola and Sylvania in the electronic hardware area; such financial firms as Dow-Jones (*Wall Street Journal*) and Merrill, Lynch, Pierce, Fenner & Smith; CATV operators TV-Communications and American TV & Communications; CATV equipment manufacturer Vikoa; publisher-broadcasters *New York Times* and Times-Mirror Co. (Los Angeles Times), and miscellaneous giants including American Express, Canadian Pacific and Eastman Kodak.

Many of these firms have little in common except an interest in orienting their own businesses to future technology. Their participation is currently exploratory. Some may back out later, while others may subsequently join up. The establishment of BCN has been informally cleared, from the legal standpoint, by the Justice Department and the FCC.

## BCN's goals

The prime mover in BCN is Arthur D. Little Inc., a management consultant and research firm which has been in the forefront in assessing the potential and impact of advancing technologies. The eventual goal of BCN is a working pilot communications system linking 10,000 to 15,000 homes in one or two locations in the U.S. to provide major new services.

"We have no idea what we'll come up with," we were told by someone close to the operation of BCN. Just about every type of service ever mentioned in the communications of the future will be examined. Among them: computerized information banks to provide consumers with such data as stock quotations, recipes, magazines, books electronically; electronic banking; television shopping; individual programmed learning in the home; airline and theater ticket sales direct to the home; prerecorded video program selection on demand; facsimile newspapers and magazines; fire and intrusion surveillance of homes; mail or telegram delivery; public opinion surveys; two-way video telephone.

The firms currently in BCN are committed only to the early phases of the program, principally involving research as to what is technically feasible and what types of services are likely to be wanted by the public. After this initial research stage, plans will be drawn up to put the results into an actual working system. After this planning stage will come the go/no-go point. If it's decided to go ahead with the actual project, a new company—BCN Inc.—will be formed, jointly owned by all participating firms. It will also offer stock to the public, with the goal of raising possibly \$15 to \$20 million for construction.

The pilot system would be in operation by 1975, according to the tentative plans of the BCN consortium, and would be designed to test the feasibility and desirability of the various services. After the initial system is operating, many options are open to BCN and its members: To set up and operate more systems, linking them into a nationwide network and becoming, in effect, a competitor of AT&T; to license other firms to establish further systems using principles and techniques proven in the pilot project; to permit various members of BCN to go their own individual ways and manufacture and sell hardware and software used in the test.

BCN is a bold concept, reminiscent in some ways of Comsat, the multi-corporation firm formed with the U.S. government to get communications satellite technology into operation. The prestigious list of companies which have been attracted into the BCN fold—and already put up preliminary seed money for the initial phases—gives some indication of how American business views its potential.

## First Teleplayer deliveries

The CBS-developed EVR player and film cartridges are now in production and being delivered. Receiving the first 200 Teleplayers, made by Motorola, was Equitable Life, which will use them to help improve the training of its agents. The consumer version of the EVR is still more than a year away.

Those firms planning to produce video tape recorders for the home have criticized CBS's EVR approach because it doesn't permit consumers to make their own home TV recordings. However, a patent recently issued to CBS Laboratories President Peter C. Goldmark may well reverse this situation. This patent covers a lightweight, low-cost camera which can make EVR recordings—on 8.3-mm black-and-white cartridge film which will play back in color through EVR Teleplayers. The color information is coded on separate frames adjacent to the optical picture frames. Unlike video tape, however, processing would be required before the EVR cartridges could be played through a color TV set. CBS Laboratories spokesmen said there are no immediate plans to produce the camera.

## Color TV prices rising

Even though the color television set market can still be described as soft and there are bargains to be had in last year's unsold models, the vast majority of manufacturers have increased the prices of their 1971 models—generally by \$10 to \$20 at retail. The story is the familiar problem which has been plaguing most industries in 1970 and 1971—rising costs of labor and materials. The popular new 25-inch super-rectangular screen-size sets have been hit with the steepest increases. However, most manufacturers are preparing lower-priced 25-inchers to fill in the gap left by raising prices on the existing models. **R-E**



## THE CAPACITOR YOU WANT, WHEN YOU WANT IT.

The widest line . . . off the shelf availability. Your nearby Mallory distributor stocks aluminums, tantalums, wet slugs, solids, foils, motor-start, motor-run, polystyrene and ceramic. In a variety that includes the capacitor you need for your immediate and future programs.



**MALLORY DISTRIBUTOR PRODUCTS COMPANY**

a division of P. R. MALLORY & CO. INC.  
Box 1658, Indianapolis, Indiana 46206

Batteries • **Capacitors** • Controls • CRIME ALERT® • DURATAPE® • Recorders • Resistors • Semiconductors • SONALERT® • Switches • Timers

*Circle 2 on reader service card*



(continued from page 2)

A similar solar telescope has been sent aloft five times on rockets and returned with x-ray photographs. Between flights, work has continued in the laboratory to further perfect and understand its imaging properties. Throughout the testing the SEC camera has been an invaluable tool.

When the Skylab is launched in 1972, it will be the first orbiting space lab. Three teams of astronauts will go up at different intervals. The first will fly 28 days and bring down a load of film with images obtained by the solar telescope. After a two-month interval, the second team will go up to spend 56 days and will return with two loads of film. After another month interval, the third team will go up for another 56-day visit and bring down a load of film from the telescope to complete the mission. ★

## CALLING ALL PHOTOGRAPHERS

There's an electronic thermometer construction article that starts on page 40. You'll find it to be an easily-built, yet extremely handy addition to your darkroom. It's written by our new photographic electronics editor; James A. Gupton, Jr.

# Safer; Sharper X-Ray Pictures

STAMFORD, CONN.—An automatic device that reduces patients' x-ray exposure, produces sharper x-ray pictures, and virtually eliminates the need for "retakes", has been introduced by The Machlett Laboratories, Inc., a subsidiary of the Raytheon Company.

Called "Dynadex", the new device acts like a variable choke or iris attached to the output window of an x-ray tube. It limits the beam of x-rays to the area of the film being used. X-rays falling beyond the dimensions of the film unnecessarily expose the patient's body while con-



tributing nothing to the diagnosis.

A recent survey by the U.S. Public Health Service indicated that as much as two-thirds of the x-rays from a typical diagnostic procedure fall beyond the limits of the film and hence should be eliminated.

The new Machlett device senses the size of the x-ray film being used and automatically shutters a series of lead leaves to make the beam conform. In addition to reacting to the size of the film being used, the "Dynadex" also generates a distance signal. Logic circuits do the calculating and the result is a sharp, accurately sized x-ray. ★

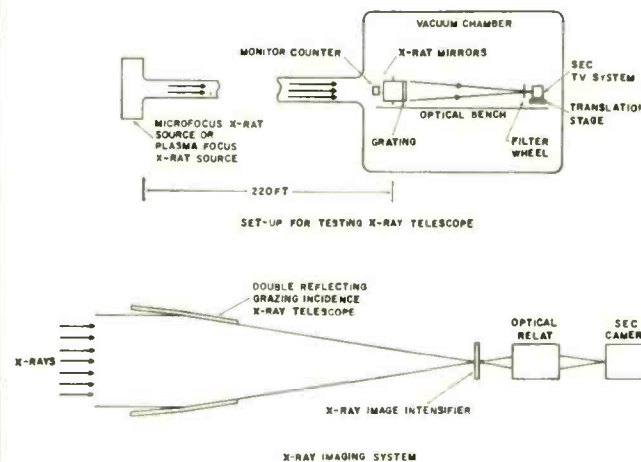

## 4-CHANNEL STEREO

Next month R-E looks into the latest happenings in 4-channel stereo. There's tape now, talk of records, and details of new FM compatible systems. Whatever your interest in 4-channel stereo don't miss RADIO-ELECTRONICS, March 1971 issue.

(continued on page 12)

# Radio-Electronics

HUGO GERNSBACK (1884-1967)  
founder

M. HARVEY GERNSBACK,  
editor-in-chief and publisher

LARRY STECKLER, editor

Robert F. Scott, W2PWC  
senior technical editor

Jack Darr, service editor

I. Queen, editorial associate

Matthew Mandl, contributing editor

David Lachenbruch, contributing editor

James A. Gupton, Jr.,  
photographic electronics editor

Vincent P. Cicenja, production manager

Barbara Rosefelt, production assistant

H. Matysko, circulation

Cover design by Marius Trinque

Cover photo by Phil Koenig

RADIO-ELECTRONICS is published by Gernsback Publications, Inc. 200 Park Ave. South New York, N.Y. 10003 (212) 777-6400

President: M. Harvey Gernsback  
Secretary: Bertina Baer

## ADVERTISING SALES

**EAST**  
Stanley Levitan, Eastern Sales Mgr.  
N.Y.C. (212) 777-6400

**MIDWEST/Texas/Arkansas/Okla.**

Ralph Bergen,  
6319 N. Central Ave.  
Chicago, Ill. 60646  
(312) 792-3646

**PACIFIC COAST/Mountain States**  
J. E. Publishers Representative Co.,  
8560 Sunset Blvd., Suite 601  
Los Angeles, Calif. 90069  
(213) 659-3810

420 Market St. San Francisco, Calif.  
94111, (415) 981-4527

**SOUTHEAST**  
E. Lucian Neff Associates  
25 Castle Harbor Isle  
Fort Lauderdale, Florida 33308  
(305) 566-5656

**SUBSCRIPTION SERVICE:** Send all subscription orders and correspondence to RADIO-ELECTRONICS, Subscription Department, Boulder, Colo. 80302.

**MOVING?** For change of address, allow six weeks, furnishing both the old and new addresses and if possible attaching label from a recent issue below. Otherwise please print clearly your name and address exactly as it appears on your label.

ATTACH LABEL HERE

name \_\_\_\_\_ (please print)  
address \_\_\_\_\_  
city \_\_\_\_\_ state \_\_\_\_\_ zip code \_\_\_\_\_

Mail to: RADIO-ELECTRONICS  
SUBSCRIPTION DEPT., BOULDER, COLO. 80302

RADIO-ELECTRONICS



# THE SANSUI QS-1 QUADPHONIC SYNTHESIZER®



**SANSUI QS-1**

## 4-CHANNEL SOUND FROM ANY 2-CHANNEL SOURCE Senses and recovers the ambient information hidden in your stereo discs, tapes and broadcasts

After having discovered that the ambient components of the original total sound field are already contained in hidden form, in conventional stereo records, tapes and broadcasts, Sansui engineers developed a method for sensing and recovering them. These subtle shifts and modulations, if re-introduced, breathtakingly recreate the total of the original sound as it existed in the recording or broadcast studio.

The heart of the Sansui Quadphonic Synthesizer® is a combination of a unique reproducing matrix and a phase modulator. The matrix analyzes the 2-channel information to obtain separate direct and indirect components, then redistributes these signals into a sound field consisting of four distinct sources.

This type of phase modulation of the indirect components, applied to the additional speakers, adds another important element. It sets up a complex phase interference fringe in the listening room that duplicates the multiple indirect-wave effects of the original field. The result is parallel to what would be obtained by using an infinite number of microphones in the studio (M1 through Mn in the accompanying illustration) and reproducing them through a corresponding number of channels and speakers.

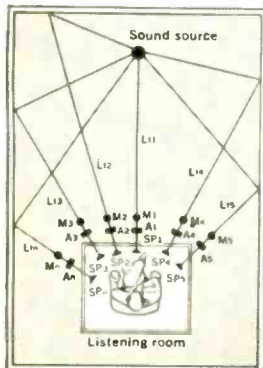
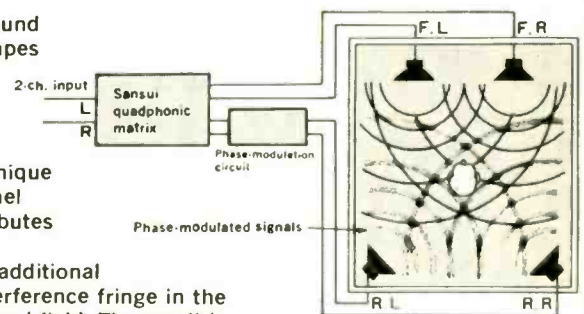

The startling, multidimensional effect goes beyond the four discrete sources used in conventional 4-channel stereo, actually enhancing the sense of spatial distribution and dramatically expanding the dynamic range. Also, the effect is evident anywhere in the listening room, not just in a limited area at the center. And that is exactly the effect obtained with live music! This phenomenon is one of the true tests of the Quadphonic system.

The Sansui Quadphonic Synthesizer QS-1 has been the talk of the recent high-fidelity shows at which it has been demonstrated throughout the country. You have to hear it yourself to believe it. And you can do that now at your Sansui dealer. Discover that you can hear four channels plus, today, with your present records and present stereo broadcasts. \$199.95.

\*Patents Pending



**SANSUI ELECTRONICS CORP.**

Woodside, New York • Gardena, California

SANSUI ELECTRIC CO., LTD., Tokyo, Japan • Frankfurt a M., West Germany  
Electronic Distributors (Canada), British Columbia

Circle 3 on reader service card

**NRI “hands-on” training  
in TV-Radio, Electronics  
can give you as much as  
2 years of on-the-job  
experience.**

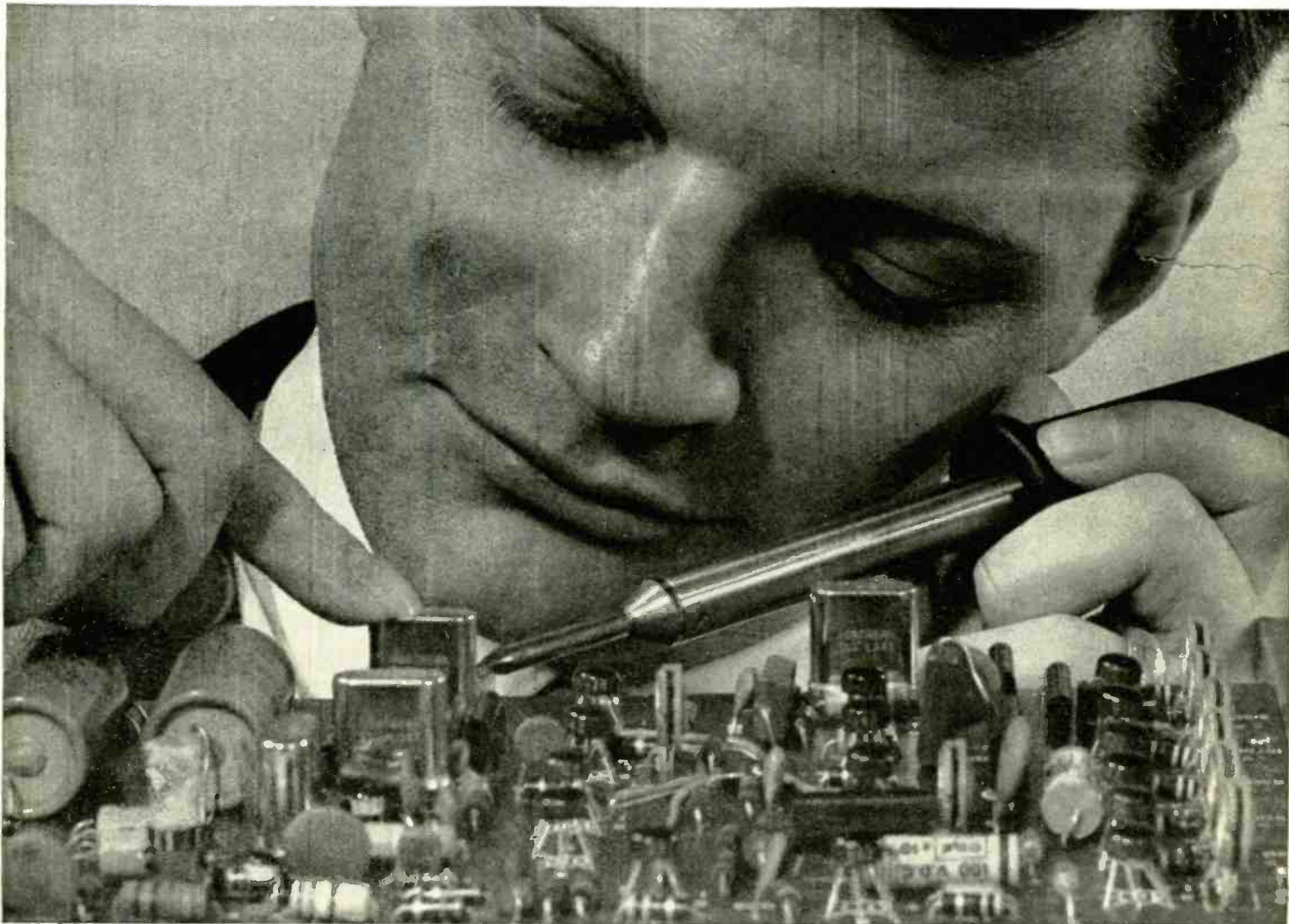

**EARN YOUR FCC LICENSE – OR YOUR MONEY BACK**

NRI Communications training programs will qualify you for a First Class Commercial Radiotelephone License issued by the FCC. If you fail to pass the FCC examinations for this license after successfully completing an NRI Communications course we will, on request, refund in full the tuition you have paid. This agreement is valid for the period of your active student membership and *for six months* after completion of your training. No school offers a more liberal FCC License agreement.



# Experience is still your best teacher

*...here's how you get it with unique NRI training at home*

Ask any teacher, job counselor, engineer, technician or prospective employer about the need for practical application of theory in Electronics. He'll tell you Electronics is as much a "hands-on" profession as dentistry or chemistry. That's how you learn at home with NRI. You prove the theory you read in "bite-size" texts, by actual experimentation with the type of solid-state, transistor and tube circuits you'll find on the job today — *not* hardware or hobby kits. You introduce circuit defects, analyze results, discover quickly the kind of trouble-shooting and design techniques that will make you employable in Electronics.

## *Train with the leader—NRI*

NRI lab equipment is designed from chassis up for effective, fascinating training — not for entertainment. The fact that end results are usable, quality products is a bonus. In Communications, for example, you build and analyze, stage by stage, your own 25-watt phone/cw transmitter. It's suitable for use on the 80-meter amateur band, if you have an interest in ham radio. In TV-Radio Servicing your practical training gives you your choice of monochrome or color TV sets. All training equipment is included in the low tuition — you pay nothing extra. Discover for yourself the ease, excitement and *value* of NRI training. Mail postage-free card today for new NRI Catalog . . . or use the coupon below. No obligation. No salesman will call on you. NATIONAL RADIO INSTITUTE, Washington, D.C. 20016.



**NRI Achievement Kit** is educator-acclaimed and the original "starter" kit in home study training. Imitated but never duplicated, this kit is designed and personalized for you and your training objective. It has one purpose — to get you started quickly and easily.

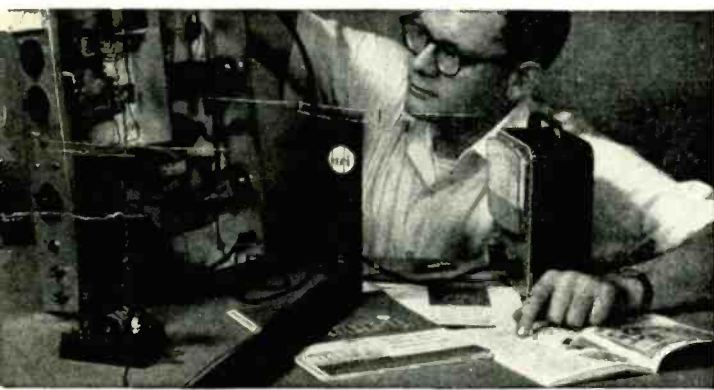

**"Bite-Size" Texts** average an easily-digested 40 pages of well-illustrated, scientifically prepared subject matter in the course of your choice. Questions in each book are carefully hand-graded and returned to you with helpful instructional notes. You get unlimited personal help from the day you enroll.



## **Designed-For-Learning Equipment**

Like this phone-cw transmitter (Kit #7 in the Communications course) is engineered from chassis up to demonstrate principles you must know. NRI does not use modified hobby kits for training, but the finest parts money can buy, professionally and educationally applied.

### APPROVED UNDER NEW GI BILL

If you have served since January 31, 1955, or are in service now, check GI line on postage-free card or in coupon.

MAIL THIS COUPON IF CARD IS GONE



**NATIONAL RADIO INSTITUTE**

Washington, D.C. 20016

3-021

Please send me your new NRI Catalog. I understand no salesman will call and there is no obligation.

Name \_\_\_\_\_ Age \_\_\_\_\_

Address \_\_\_\_\_

City \_\_\_\_\_ State \_\_\_\_\_ Zip \_\_\_\_\_

Check for facts on new GI Bill

ACCREDITED MEMBER NATIONAL HOME STUDY COUNCIL

## AUDIOVISUAL TV SERVICE AIDS FOR TECHNICIANS

HARRISON, N. J.—Three new audiovisual informational programs designed to furnish practical guidelines and solutions to technicians in everyday servicing of television receivers and other electronic equipment are available from RCA distributors.

The new technical service aids cover critical areas in specific detail to save service technicians time and trouble. Each program consists of a series of color slide presentations containing professional graphics and illustrations, an audibly-synchronized cassette tape recording and a brochure recapping the salient points necessary to achieve maximum effectiveness. 35mm projector and a standard cassette tape recorder are required for group or individual presentation.

The first tape-cassette/slide-film presentation is

entitled "Color TV Picture Tube Installation and Associated Receiver Adjustments". It offers specifics on color picture tube replacement; outlines safety precautions; indicates short cuts on tube removal and replacement; and provides a step-by-step guideline covering convergence, purity, and tracking—intermixed with electronic theory for greater understanding of TV electronics.

The second aid covers "Basic Techniques For Transistor Checking" (1L1337). It explores the use of basic test equipment; provides simple techniques for transistor checking; reveals quick ways to identify unknown transistor leads and types, and offers cost-saving information on good servicing practices, techniques and short cuts.

The third service aid deals directly with a no-raster problem and is entitled "Tele-

vision Servicing; No Raster Condition". This presentation provides a preliminary check list and a diagrammatic procedure recommended by RCA television specialists. Both "no raster—no sound" and "no raster—sound present" conditions are discussed in detail. Servicing techniques are presented that will save the technician's most important commodity—his time. ★

### CASSETTE ELECTRONICS

If you aren't really familiar with the electronics used in today's cassette tape recorders you won't want to miss the programmed article in the March 1971 issue. It covers cassette electronics from A to Z. In April, the mechanical side of cassette machines is detailed in the same step-by-step fashion.

## STEREO TAPE CASSETTE COMPATIBILITY

NEW YORK, N.Y.—A solution to the problem of quad-stereo-mono compatibility in cassettes has been proposed by Norelco. It calls for 3-way 4-2-1 compatibility—the capacity to play four-channel, stereo or mono cassettes interchangeably without loss of quality on any cassette machine.

Edward R. Hanson, technical manager states, "The basic mono-stereo compatibility that has prevailed so far in the cassette industry can and should be extended to the suggested four-track medium. Although it's far from clear whether the public will eventually accept four-channel as a standard mode, we must be prepared for the eventuality."

Hanson adds that the system is being offered as a basis (continued on page 14)

# NEW from the originators of "NO NOISE"

You've tried others, now try the best!

**3 years of constant research and testing have put us way ahead!**

NO NOISE has been an innovative force in the development and production of cleaners and lubricants for 25 years. Our technical people, who made us No. 1, were turned loose to create a new line that would out-perform anything on the market. Three years of experimentation and testing developed these 2 new products. Approved by leading service organizations.

### SUPER-LUBE

A miracle concentrated formulation for heavy duty jobs. Its clinging action foams away corrosion, dirt and oxidation—and polishes all tuners continuously without drift or detuning. SUPER-LUBE's built-in lubricating quality makes channel selecting smooth and easy. For color and black & white.



8 oz. \$2.35

Introductory Offer

BUY 4 CANS OF SUPER-LUBE AND GET 2 EXTRA CANS FREE FROM YOUR JOBBERS! MONEY BACK GUARANTEE!

**SUPER SPRAY BATH** dissolves and flushes away grease, dirt, oil and oxidation. Simply spray! tuners, its penetrative action cleans and restores tuners inside and out.

All NO NOISE products are non-toxic - non-flammable - no carbon tet - safe for all plastics.



24 oz. \$3.25

# ecc

Often imitated but never duplicated

813 Communipaw Avenue  
Jersey City, N. J. 07304

ELECTRONIC CHEMICAL CORP.

Circle 4 on reader service card

## TeleMatic

## BRIGHTENERS For Those Problem Picture Tubes



### BLACK & WHITE

UNIVERSAL • for all voltages and currents

TYPE MODEL

DOUDECAL CR-69

RCA 110° CR-154

SYLVANIA 110° CR-159

MINIATURE BASE CR-12

### COLOR

70°—CR-200

90°—CR-250

### 2 IN ONE ISOLATION COLOR

Test for and cure Cathode-Heater shorts and low emission.

70°—CR-300

90°—CR-350

Ask Your Distributor

TELEMATIC, BKLYN, N.Y. 11207

Circle 5 on reader service card

Circle 6 on reader service card →





# CALMS TAPE TENSION.

Headache? Take aspirin.

Tape tension trouble? Take TEAC.

For instance, take the A-6010U stereo tape deck here – with its unique tape tension control system: an inertial flywheel and compliance-arm for precision record/playback running speeds and smooth, fast winding. This system helps reduce external factors contributing to wow and flutter, such as warped reels and splices.

TEAC offers fast relief for other common complaints, too: unique *phase sensing auto reverse* operates electronically at any chosen point on the tape, or takes a sensing foil if you'd rather. Separate heads permit *source- or off-the-tape monitoring while recording* for easy A/B comparisons. And our exclusive *symmetrical control system* makes tape handling logical and easy – fast or slow, forward or back, at a flick of the finger.

This tape deck can't cure everything that ails you, but you're bound to feel better once you own one.

## TEAC

TEAC Corporation of America • 2000 Colorado Avenue • Santa Monica, California 90404



# New & Timely

(continued from page 12)

for industry standardization in much the same manner as the original Norelco/Philips cassette was offered a number of years ago.

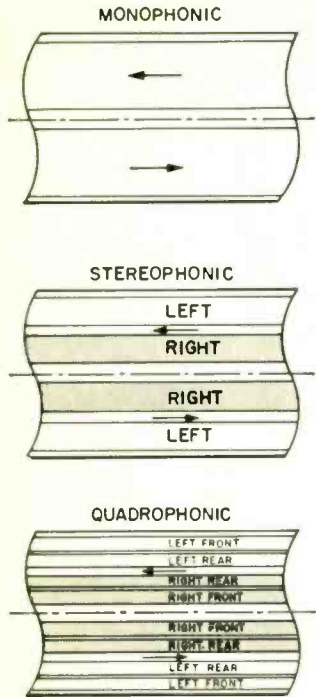

In the Norelco approach, four discrete channels are placed in the space occupied by the two stereo tracks on a standard cassette tape. Since cassettes record and play back in two directions, the process results in a dual four-

channel configuration, with four tracks for recording and playback in one direction and four tracks in the other.

The new format places two distinct sound sources in the space now occupied by one source in a stereo cassette. The width of individual tracks is reduced from 0.0264 inches to 0.0110 inches.

The smaller channels produce a reduction in signal-to-noise ratio, but in practice dispersion is said to reduce the disturbance level. ★

**PROPOSED TAPE STANDARDS** for cassettes. Left: positions of tracks for compatible mono, stereo and 4-channel stereo. Below: 4-channel specifications.

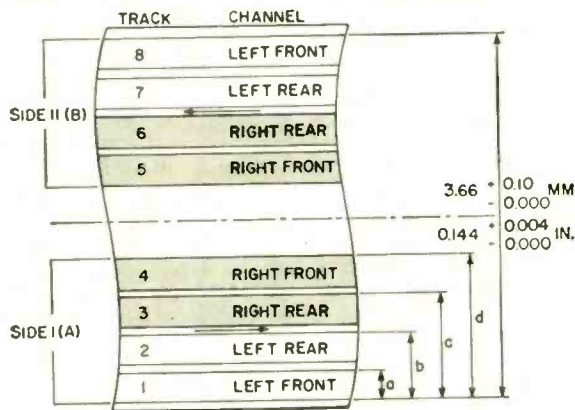

## CODE-COM READY

COLUMBUS, OHIO—This new instrument, now available to telephone users permits deaf, or deaf-blind, persons to communicate via the telephone.



The set contains a light, sending key and vibrating disc. A deaf person watches the flashes of light; a deaf-blind person feels the vibrations. The key is used to transmit messages using a pre-arranged code for simple messages or Morse code. R-E

## NO COMPETITORS

Nobody else but **EMC** designs in so much value



Tube Tester Model 213

Compact, light-weight portability. Use it on the bench or in the field.

Full-view meter gives direct, clear-cut quality indications.

Three heavy-duty controls for quick set-up of all tests. Check a fistful of tubes in the time it often takes to test one.

12 slide switches for individual selection of tube pins provides versatility in testing, prevents obsolescence.

Full complement of sturdy sockets accepts compactron (12-pin), nuvistor, novar, 10-pin, 9-pin, octal, loctal, and miniature tubes.

Precise programming. Only one socket per tube-base configuration prevents accidental plug-in.

THE MODEL 213 saves you time, energy, money ■ Checks for shorts, leakage, intermittents, and quality ■ Tests all tube types including magic eye, regulator, and hi-fi tubes ■ Checks each section of multi-purpose tubes separately ■ Gives long, trouble-free life through heavy-duty components, including permanently etched panel ■ Your best dollar value in a tube tester. Available in high-impact bakelite case with strap: \$33.40 wired; \$21.90 in kit form. Wood carrying case (illustrated) slightly higher.



**ELECTRONIC MEASUREMENTS CORPORATION**  
625 Broadway, New York 12, New York  
Export: Pan-Mar Corp., 1270 B'way, N. Y. 1, N. Y.

EMC, 625 Broadway, New York 12, N. Y.  
Rush me FREE catalog describing all EMC value-loaded test instruments and name of local distributor.

NAME \_\_\_\_\_  
ADDRESS \_\_\_\_\_  
CITY \_\_\_\_\_ ZONE \_\_\_\_\_ STATE \_\_\_\_\_

**THOUSANDS OF BARGAINS—TOP VALUES IN Electronic Parts**

Transistors, Modules, Speakers, Stereo, Hi-Fi, Photo Cells and thousands of other Electronic Parts. Send for **FREE** Catalog

**ELECTRONIC DISTRIBUTORS INC.**  
Dept. TA-2, 4900 Elston  
Chicago, Ill. 60630

RUSH CATALOG

Name \_\_\_\_\_  
Address \_\_\_\_\_  
City \_\_\_\_\_ State \_\_\_\_\_ Zip Code \_\_\_\_\_

Circle 7 on reader service card

RADIO-ELECTRONICS



# LOTS

# NEW

A broad new line of exciting, laboratory grade test instruments from Leader, for servicing all electronic equipment—priced to give you the best dollar-for-dollar value—and built to the highest standards in the industry!

Leader's got it in New, Portable Triggered Scopes; Battery Operated Color Bar Generators; Post Injection Sweep Marker Generators; and lots more. Accessories too. Seeing is believing. Send for your new catalog. See your distributor.

FROM

# LEADER

## LOTS OF SCOPE...



LBO-301

Here's the only 3" Portable Triggered Scope with vertical and horizontal calibration! All solid state, it features highest sensitivity, wide bandwidth and an easy-to-use, horizontal panel design for testing under all conditions. Great for servicing color TV and computer circuitry. It's compact, it's portable, it's remarkably low-priced. \$334.50

## LOTS OF STABILITY...



LCG-384

Our fabulous, new, Mini-Portable Color Bar Generator that's battery operated, yet offers test patterns of the highest stability. Features Leader's digital clock and binary system that acts as a miniature computer. Has two switch selectable frequencies, four basic patterns including gated rainbow for testing NTSC color sets. With carry case, extra battery compartment and all accessories. \$109.50

## LOTS OF SENSITIVITY...



LBO-54B

This 5" Wideband Scope features calibrated vertical input, 10MVp/cm sensitivity and unstinting operational stability. Bandwidth is DC to 10MHz and the high linearity sweep range has automatic synch. DC coupling and push-pull amplifiers help deliver distortion-free displays. \$249.50

## AND LOTS MORE...

- From left to right here's our
- LBO-501—5" Triggered Scope/  
Vectorscope ..... \$339.50
- LSW-330—Solid State Post  
Injection Swemar  
Generator ..... \$399.50
- LBO-32B—3" Wideband  
Oscilloscope ..... \$189.50
- LDM-810—Grid Dip  
Meter ..... \$44.50

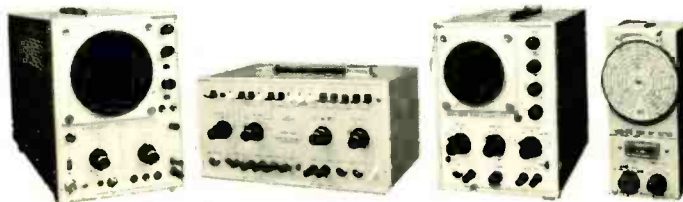

Seeing is believing.

# Leader

TEST INSTRUMENTS

37-27 27th Street, Long Island City  
New York 11101.

Telephone: (212) 729-7410

Circle 8 on reader service card

# **FREE! YOUR FIRST CAN OF TUN-O-BRITE IS ON US!**



ONLY ONE  
FREE CAN  
TO A  
TECHNICIAN.

This offer expires  
March 1, 1971

We say TUN-O-BRITE is head and shoulders above any other tuner spray you've ever tried. You say you've heard that song before.

It's time for us to put our money where our claims are. Tell you what we're gonna do. Buy a can of TUN-O-BRITE from your favorite distributor — at the regular price.

When you've used the TUN-O-BRITE up, send the empty can to us. We'll send you a new can *OF YOUR FAVORITE TUNER SPRAY FREE!*

There are no strings attached to this offer. If you ask for TUN-O-BRITE, we'll be delighted to send you another can absolutely free. If you ask for a competitive brand, we'll be disappointed, but we'll send it to you anyhow. Either way, you can't lose. You get to try TUN-O-BRITE at our expense because you can swap the empty can for a free can of your favorite tuner spray.

Of course, we're betting that once you try TUN-O-BRITE, you simply won't settle for any other product, no matter how cheap you can buy it. After all, you can tell a professional TV technician by the tools he uses.

## **CHEMTRONICS** I N C



1260 RALPH AVE.  
BKLYN., N.Y. 11236

Circle 9 on reader service card



# WHO

stands to benefit most from Color TV?

Everyone, including the service technician, has a lot to gain. That's why Sprague wants to help you get your fair share of this increasing business.

# NEEDS

of the service technician are of great importance to Sprague. That's why we supply capacitors with the exact ratings required to meet the exacting requirements of Color TV.

# COLOR

has been both boon and bane of the service trade. While it has added to service volume, it has also caused some headaches. That's why Sprague is constantly striving to simplify Color TV capacitor selection.

# TV?

Yes, TV repair represents a big portion of your business. And color is boosting it even higher. You do faster, surer work with Sprague replacement capacitors for Color TV.

---

**THE BROAD-LINE PRODUCER OF ELECTRONIC PARTS**



Sprague® and '®' are registered trademarks of the Sprague Electric Co.

*Circle 10 on reader service card*

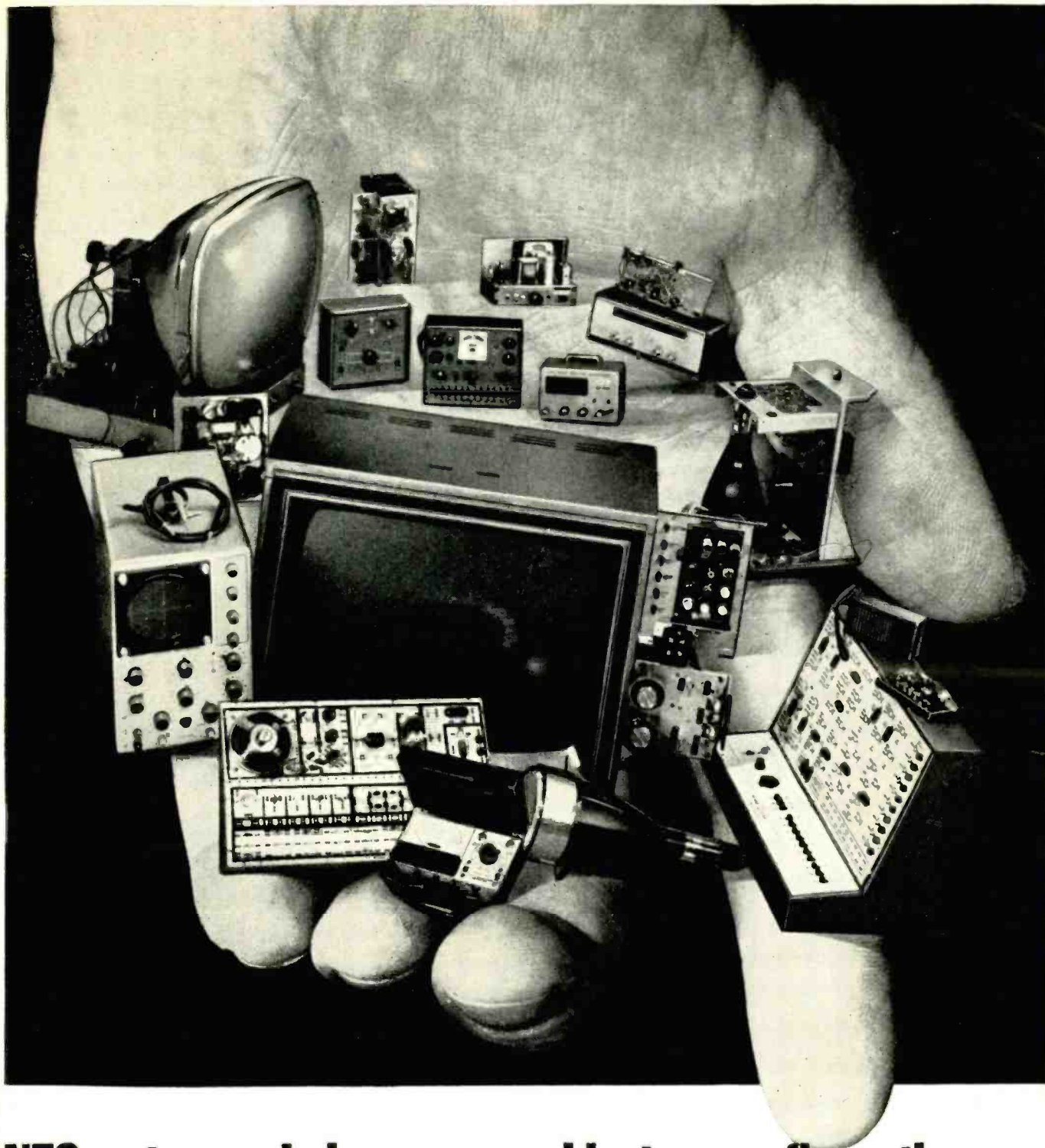

## NTS puts a whole new world at your fingertips.

NTS home training can put a whole new way of life in the palm of your hand. A new, exciting job, a much bigger income is now easily within your reach.

NTS training is something special. We provide all the kits you need for the most effective training. National Technical Schools sends kits with every course, and teaches you to build and test a

wide range of professional equipment — the same kind of equipment you'll actually use on the job. That's the NTS "Project Method" — training that's practical and in-depth. You learn everything from fundamentals to the latest innovations. From beginning to end, NTS makes it fascinating and fun to learn this way. And all you need is a little

spare time and an interest in electronics.

Each year, men are moving into important new jobs, or their own businesses, straight out of NTS electronics training. NTS is what's happening to men everywhere. Check the coupon. Take hold of the career you want most. Do it now. No obligation. No salesman will call.



**We pack your electronics course with kits to make your training fast. You'll enjoy every minute of it.**

**NTS COLOR TV SERVICING**

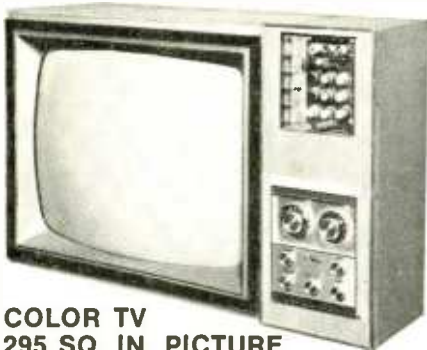

**COLOR TV  
295 SQ. IN. PICTURE**

NTS training provides an easy way to become a professional home-entertainment service technician. You receive a big screen Color TV with many unique features. The unit even includes self servicing equipment that permits you to make all normal test operations. No additional test equipment is needed for adjusting your set. In addition you get an AM-SW radio, Solid-State radio, Field-Effect Transistor Volt-Ohmmeter, and Electronic Tube Tester. You learn about Electronic principles and trouble shooting, hi-fi, multiplex systems, stereo, and color TV servicing.

**NTS COMPUTER ELECTRONICS**

This is the future. And it's happening now. The number of computers will *increase many times* in the next few years.

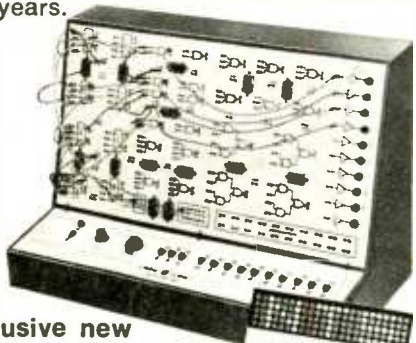

**Exclusive new Compu-Trainer®**

If card is missing check coupon and mail for free color catalog and sample lesson. Now.



**National Technical Schools**  
4000 S. Figueroa St., Los Angeles, Calif. 90037  
Please rush Free Color Catalog and Sample Lesson, plus information on course checked below. No obligation. No salesman will call.

NTS offers a solid grounding in computer operation, wiring, data processing and programming. One of the 10 important kits included is our exclusive Compu-Trainer®. It's a fully operational computer logic trainer — loaded with integrated circuits — the first ever offered in home study. It introduces you quickly to how, what, when and why of computers . . . from theory to practical servicing techniques. This unit is capable of performing 50,000 operations per second.

**NTS ELECTRONICS COMMUNICATIONS**

Choose from two exciting courses to get into the big-paying fields of transmitting and receiving equipment: (1) The FCC License Course. (2) The Master Course in Electronic Communications (more comprehensive, with Citizens' Band Two-Way-Radio). Either Communications program qualifies you for your FCC First Class Commercial Radio-Telephone License — *NTS assures you will pass this FCC exam within six months after successfully completing your course or your tuition is refunded.* Kits include an Amateur-Phone 6 Meter VHF Transceiver — NTS exclusive, 6 transistor Solid-State Radio, Volt-Ohmmeter (fully transistorized).



**5 Watt AM Transmitter/Receiver**

**NTS AUTOMATION/ INDUSTRIAL ELECTRONICS**

Let NTS put you into the age of electronic controls. Systems Automation is rapidly becoming the emphasis of modern industry. Your NTS training in automation electronics includes equipment like a 5" wide band Oscilloscope. You also get the new NTS Electronics Lab. It's an exclusive NTS experimental laboratory — a complete workshop that simplifies learning about solid-state, miniature and integrated circuits.

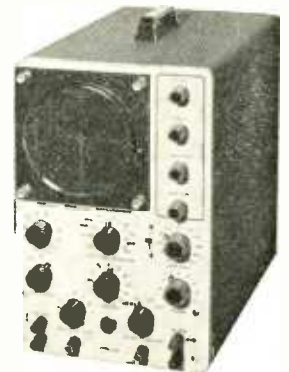

**5" Oscilloscope**

**CLASSROOM TRAINING AT LOS ANGELES**

You can take classroom training at Los Angeles in sunny Southern California. NTS occupies a city block with over a million dollars in facilities devoted exclusively to technical training. Check box in coupon.

**NATIONAL TECHNICAL SCHOOLS**  
WORLD-WIDE TRAINING SINCE 1905

4000 South Figueroa Street  
Los Angeles, Calif. 90037, U.S.A.

**APPROVED FOR VETERANS**

Accredited Member: National Association of Trade and Technical Schools; National Home Study Council.

- Master Course in Color TV Servicing
- Color TV Servicing
- Master Course in TV & Radio Servicing
- Practical TV & Radio Servicing
- Master Course in Electronic Comm.
- FCC License Course
- Master Course in Electronics Tech.
- Industrial and Automation Electronics
- Computer Electronics
- Basic Electronics

Name \_\_\_\_\_ Age \_\_\_\_\_

Address \_\_\_\_\_

City \_\_\_\_\_ State \_\_\_\_\_ Zip \_\_\_\_\_

- Check if interested in Veteran Training under new G.I. Bill
- Check if interested *only* in Classroom Training at Los Angeles

Dept. 206-021

# Correspondence

## THANKS FOR THE MIXER

I had been looking for a good straight-forward mixer circuit when I saw the cover article in the October 1970 issue of RADIO-ELECTRONICS. It

seemed to be exactly what I was looking for so I decided to try it. I have been extremely satisfied with the final

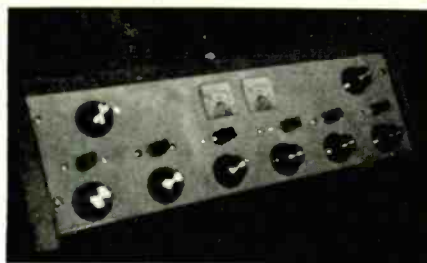

results. My final project does not look anything like yours (see photos), but it does exactly what I want it to and more.

I incorporated a number of features not found in your original design and eliminated a few you had put in, only because my needs are different.

A small cue amplifier is incorporated in the console as well as monitor muting. This was all easily accomplished because of your no-pop

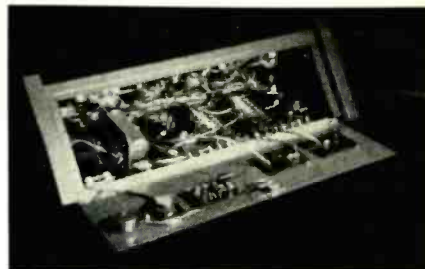

no-click circuit. All switching is done with non-shorting switches with no problems.

I have made frequency response, distortion and noise tests for both channels and they are not too bad. The only thing I would like to see a bit better would be the noise figure. The overall noise increases considerably when either the master or pre-amp gains are increased from the test levels. I'm sorry to say that I couldn't use the same transistors you did because they are not as readily available as others in this area. I used 2N3393's for low level, GE-20 and GE-18 for line amplifier and mixer boards.

I did have one problem, but it was probably due to the different transistors. The output transistor in the power supply kept opening. I inserted a 10-ohm, 1/2-watt resistor in series with the transformer secondary and had no further problem.

I did find the gain from the mike preamps is tremendous, even with low output cardioid mikes. This probably helps to account for some of the noise.

Thanks for your time and a good circuit when it was needed most.

JULIAN E. JETZER  
Sheboygan, Wis.

*Julian, when you start substituting transistors you never know exactly what will happen. If you stuck to the units specified you might have gotten the better results you were looking for. Your unit looks great and we're pleased to see that you were able to make good use of the article.*

*We'd like to see pictures of other construction projects assembled by readers, especially when they've made modifications and changes. Other readers would like to hear about them too. Just drop us a short note and include a snapshot or two of your gear. Maybe you'll get to see yours in this column too.*

R-E

# PUT IT TO THE TEST

Leave it to B&K to come up with a new model 179 FET/VOM with features that almost make it unbelievable at its price. Complete DC voltage ranges from .3V to 1000V; DC current ranges .03 to 300 mA; AC voltage ranges .3 to 1000V and AC current ranges .03 to 300 mA. Resistance 0 to 500 Meg and stable operation 0° to 40°C. Fastest and easiest to use.

The 179 uses Field Effect Transistors for drift-free accuracy. High input impedance minimizes circuit loading. And the 179's super-wide variety of ranges makes this an ideal FET/VOM for shop, lab, production line, or school. Includes mirror scale, and stay-put handle.

Now is the time to update your shop with a stable, protected FET/VOM. And the economical, yet professional B&K 179 is the instrument that will give the most usefulness and satisfaction for your money.



Ask your distributor or write us for catalog.

There is a difference in test equipment . . . ours works!

**B&K Model 179 FET/VOM \$74.95**  
The new standard of stability



A Product of  
DYNASCAN CORPORATION  
1801 W. Belle Plaine  
Chicago, Illinois 60613

Circle 11 on reader service card



Winter can't drag the new ruggedized  
Color Crossfire down!



Now the world's most popular color TV antenna has even greater strength to keep it standing firm through the Winter storms!

The new ruggedized Color Crossfire features 30% stronger rear elements that take heavy snow and ice loading and still deliver their message.

Other body building improvements include a rugged, one-piece all aluminum harness

that won't rust or wrench out of shape, and will keep all elements working in perfect harmony. And preassembled hardware that makes the Color Crossfire the world's easiest, as well as strongest antenna installation.

So now, with Winter wind, snow and ice dragging lesser antennas down to earth, the Color Crossfire is keeping its new blue boom up, and its elements on target!

## The new ruggedized Color Crossfires

### **CHANNEL MASTER**

DIV. OF AVNET, INC., ELLENVILLE, N.Y. 12428

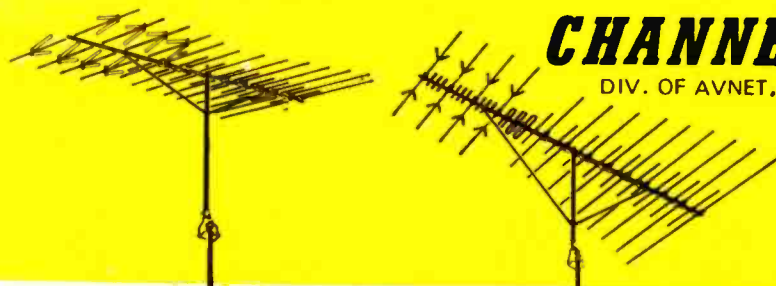

Circle 12 on reader service card



# YOUR SOLDERING GUN IS OBSOLETE

Ungar's New #6760 Makes it so.

Now Ungar gives you the better gun to tackle the most critical soldering jobs... the kind of jobs demanded by today's sophisticated electronics. Here's why it's better. You get total electrical isolation—We grounded the gun— with a 3 wire NEMA plug and cord... so your sensitive I.C.s and densely packed components are safe from static electricity and stray currents. (It's also safer for you too.) The Isolated-Grounded Tip—a simple idea that protects both you and your circuitry.

But we didn't stop there. We designed an entirely new soldering gun for you. Instead of the usual heavy, transformer you get reliable advanced circuitry. It makes this new gun a feather-light five ounces! Now you can accurately pinpoint solder in hard-to-get-to spots without hand fatigue.

Next we added versatility. You get two heat ranges (500° and 900° F approx.)— all with the same gun. And, you have a choice of three thread-on replaceable tips that won't give or bend in constant use—select the shape that fits your needs best. For greater accessibility, you can easily lock the tip to the exact angle needed for your job.

A few other standard bonuses you get only with Ungar's new trigger-activated #6760: a virtually shatter-proof case—U.L. listed—a guarantee of excellence on each and every gun—and separately replaceable parts. But don't just take our word for it. Try one... or ask another pro who has one. Then make up your own mind.

Prove for yourself that in the age of solid state, Ungar really outguns the heavyweights.

 Division of Eldon Industries Inc.

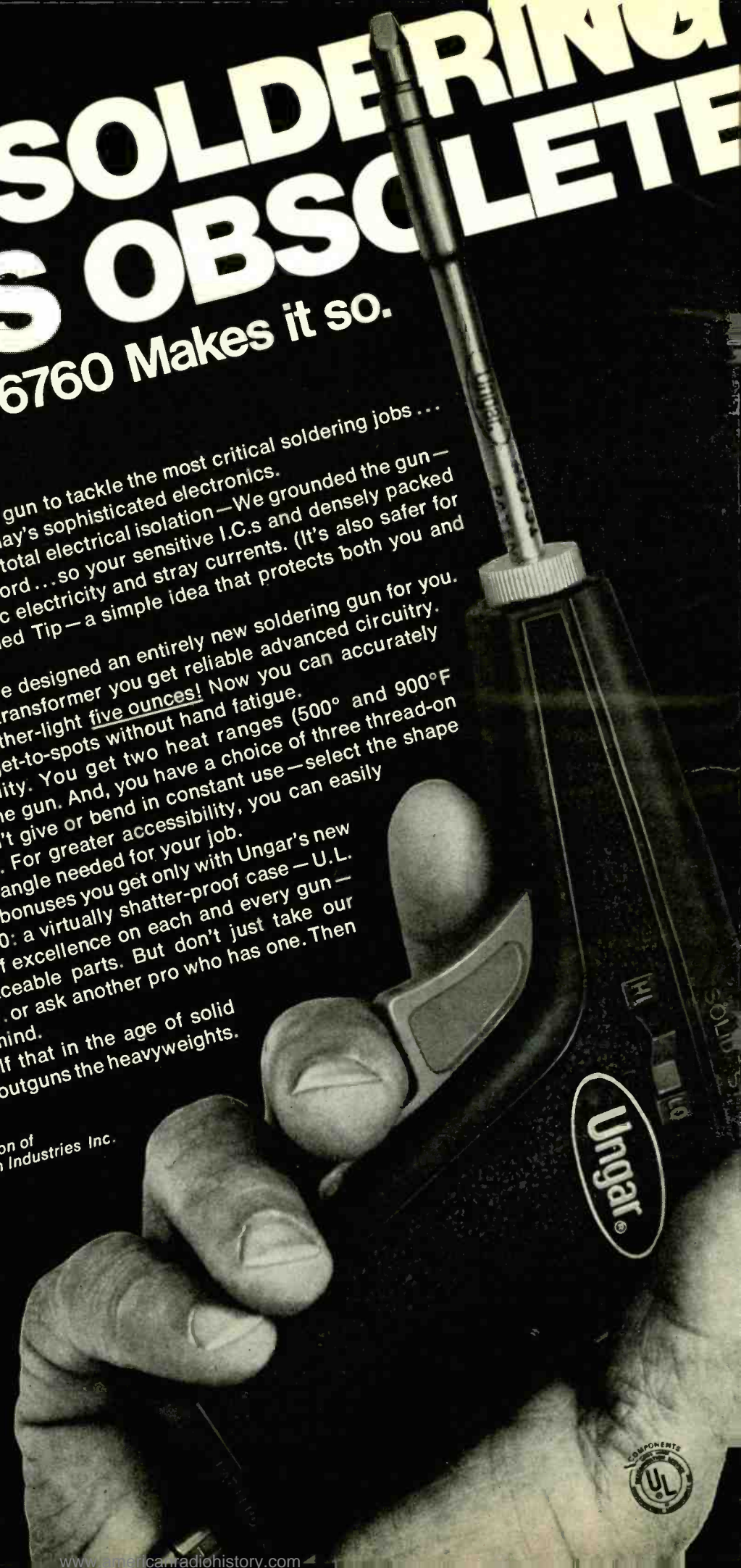



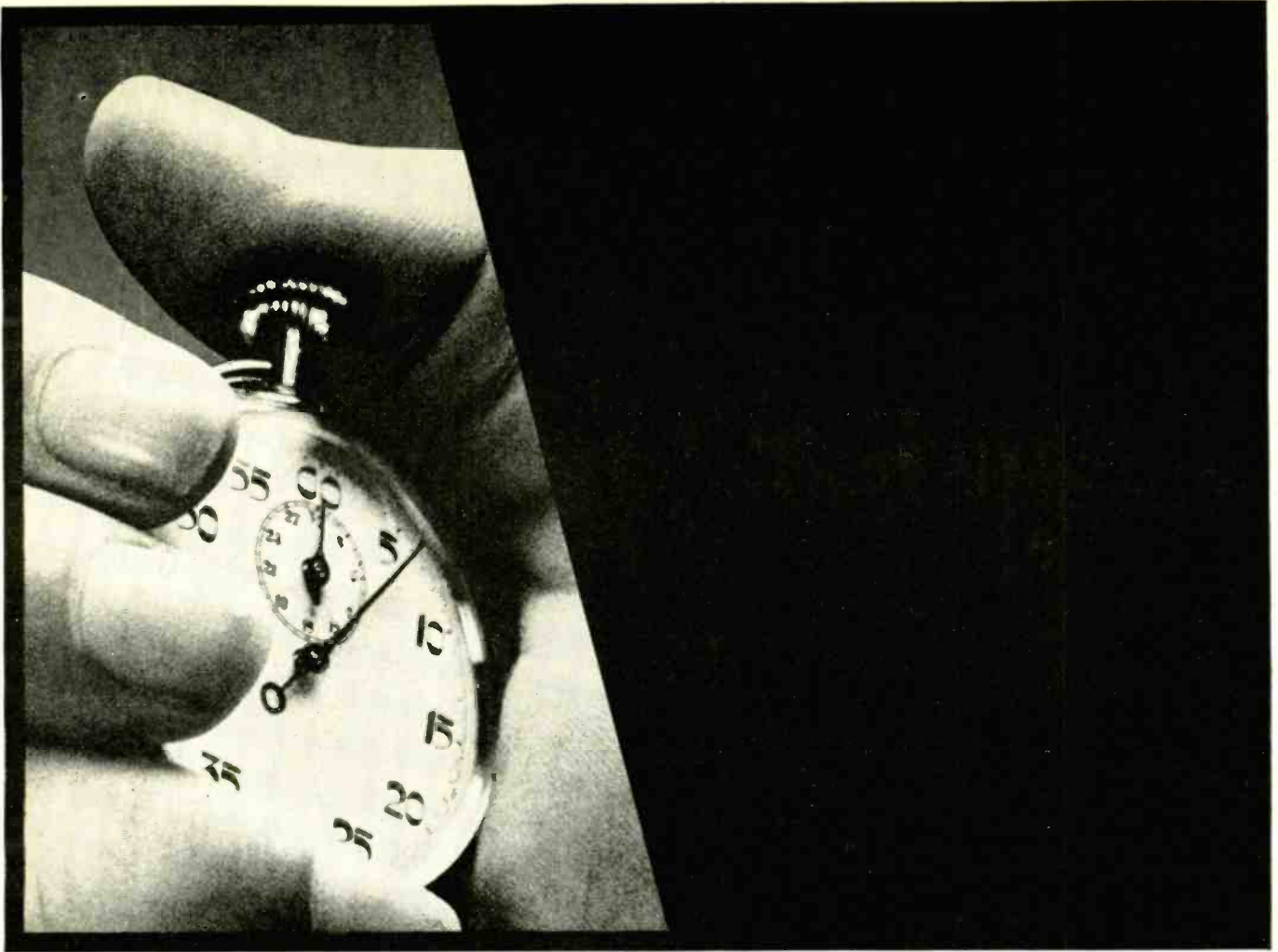

## Solve 7 problems...in seconds.



Something totally new to add to your bag of tricks! We call them *Plug-in Problem Solvers*. They're designed to provide seven common modifications in microphone and sound system setups without soldering or rewiring—just plug them in! The Model A15A Microphone Attenuator that prevents input overload; Model A15PR balanced line Phase Reverser; and A15HP High Pass and A15LP Low Pass Filters to modify low and high frequency response; A15PR Presence Adapter to add brilliance; A15RS Response Shaper to filter sibilance and flatten response; and the A15LA Line Adapter that converts low impedance microphone inputs to line level inputs. Carry them on every job. It's a lot easier than carrying a studio console with you! Shure Brothers Inc., 222 Hartrey Ave., Evanston, Ill. 60204.



**SHURE**

← Circle 13 on reader service card  
FEBRUARY 1971

Circle 14 on reader service card

# Build this exciting Schober Console Organ for only \$1040!\*

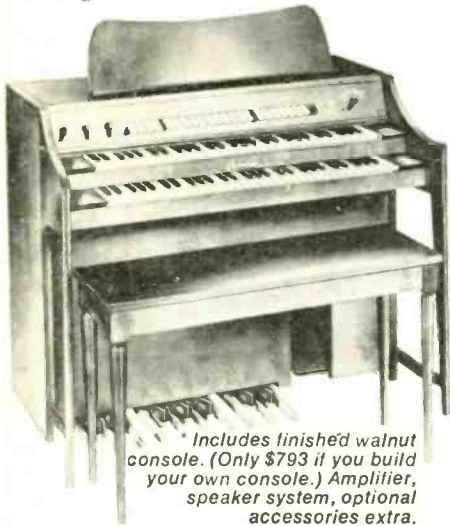

\* Includes finished walnut console. (Only \$793 if you build your own console.) Amplifier, speaker system, optional accessories extra.

You couldn't touch an organ like this in a store for less than \$1800—and there never has been an organ of the Console II's graceful small size with 22 such pipelike, versatile voices, five-octave big-organ keyboards, and 17 pedals! It sings and schmaltzes for standards, pops, old-time favorites, speaks with authority for hymns and the lighter classics, all with a range of variety and satisfying authenticity you've never found before in an instrument under church or theatre size. If you've dreamed of an organ of your own, to make your own beautiful music, even if your home or budget is limited, you'll get more joy from a Schober Console II than any other "home size" organ—kit or no kit.

You can learn to play it. And you can build it, from Schober Kits, world famous for ease of assembly without the slightest knowledge of electronics or music, for design and parts quality from the ground up, and—above all—the highest praise from musicians everywhere.

Send right now for the full-color Schober catalog, containing specifications of all five Schober Organ models, beginning at \$499.50. No charge, no obligation. If you like music, you owe yourself a Schober Organ!

The *Schober* Organ Corp., Dept. RE-87  
43 West 61st Street, New York, N.Y. 10023

- Please send me Schober Organ Catalog and free 7-inch "sample" record.
- Enclosed please find \$1.00 for 12-inch L.P. record of Schober Organ music.

NAME \_\_\_\_\_

ADDRESS \_\_\_\_\_

CITY \_\_\_\_\_ STATE \_\_\_\_\_ ZIP \_\_\_\_\_

Circle 15 on reader service card

## In the Shop . . . With Jack

By JACK DARR  
SERVICE EDITOR

### CHECKING THE CHIP

ONE OF MY ALLEGED FRIENDS ONCE GAVE me one of those signs saying "An Expert is one who knows more and more about less and less!" In some fields this is true, but the American electronics technician is just the opposite. He knows more and more about more and more! He has to. They keep throwing new things at us—color, transistors, and now integrated circuits. You name it, we fix it!

We are finding IC's in several things now and we'll find more of them as time rocks along. So let's take a look at some of the test methods and instruments needed to find the trouble and fix it. One of the first in common use is Zenith's IC color demodulator, which they call "The Chip". It has been in use for a couple of years and is doing very well.

#### Chip-checking

The chip used here is a "dual double-balanced synchronous detector" if you want the description. It contains 21 transistors and a lot of resistors, etc. However, we do not need to know this! All we need to know is the normal input and output signal amplitudes and wave-shapes, and the dc voltages at various terminals, plus the normal dc current drawn. (We can't get inside the chip to do anything; all we can do is check it to find out if it is working.)

This is the basic problem we face—is the chip working or is the trouble in the external circuitry? So we must have tests that will give us this data in the least possible time. Of course, when these first came out, the regular number of perfectly good chips were replaced. However, it is not difficult to pin down the trouble with the right test equipment and methods.

The only reliable way of checking is probably the oldest in the business. It's simply "Signal input/signal output" and dc voltages. We read the input signals, then the output signals. If they are normal, go on—the chip is ok. If they aren't normal, then we read the dc voltages at the IC terminals. If the dc supply voltage is normal, but the dc voltages at other points on the chip are not, then there is a definite chance that the IC is bad. All of the dc voltages found on other terminals (from the input supply) come "from within" the chip, and indicate trouble if they're off-value.

The diagram is the circuitry of the chip in the 14Z8C50 series Zenith chassis. All of the normal dc voltages are shown. The color signals are fed into

terminals 2 and 3, at a very low amplitude. You'll see a color-bar signal here, with a low-capacitance or crystal-detector probe on the scope, at about 0.75 volts p-p. The chip demodulates these signals, and comes out with the three color signals, red, blue and green, at a good deal greater level.

The output signals will be the familiar "rocker" waveforms, just like those you see on the tube demodulators and color-difference amplifiers. They're fed to the control grids of a triple triode 6MN8 color-difference amplifier tube, at about 10 volts p-p. The green signal, as usual, will be somewhat lower than the

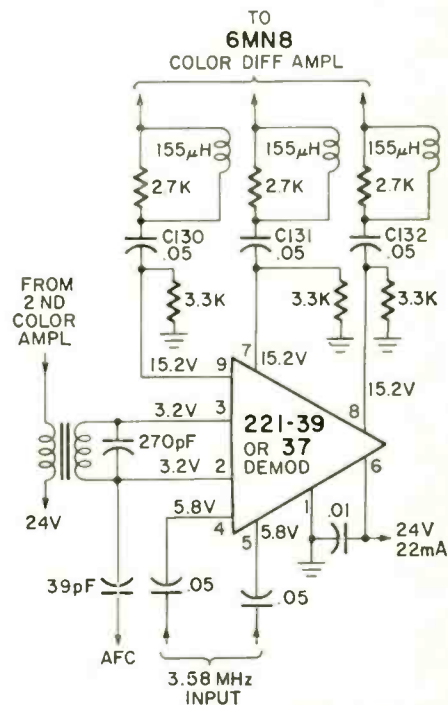

red or blue. The color outputs from the chip are pins 7, 8 and 9. They can be easily identified by the external load resistors, 3300 ohms each, and the .05 µF coupling capacitors.

So there's the first test. Feed a color-bar signal to the antenna of the set and check for these signals with a scope and low-capacitance or crystal demodulator probe. Actually, you can use a low-capacitance probe on the output. If you get the right signals here, there's no need to check the input.

#### Second-stage testing

Now suppose that we do not get a normal output. Then, we check the input. If we see the normal, very low level

(continued on page 82)



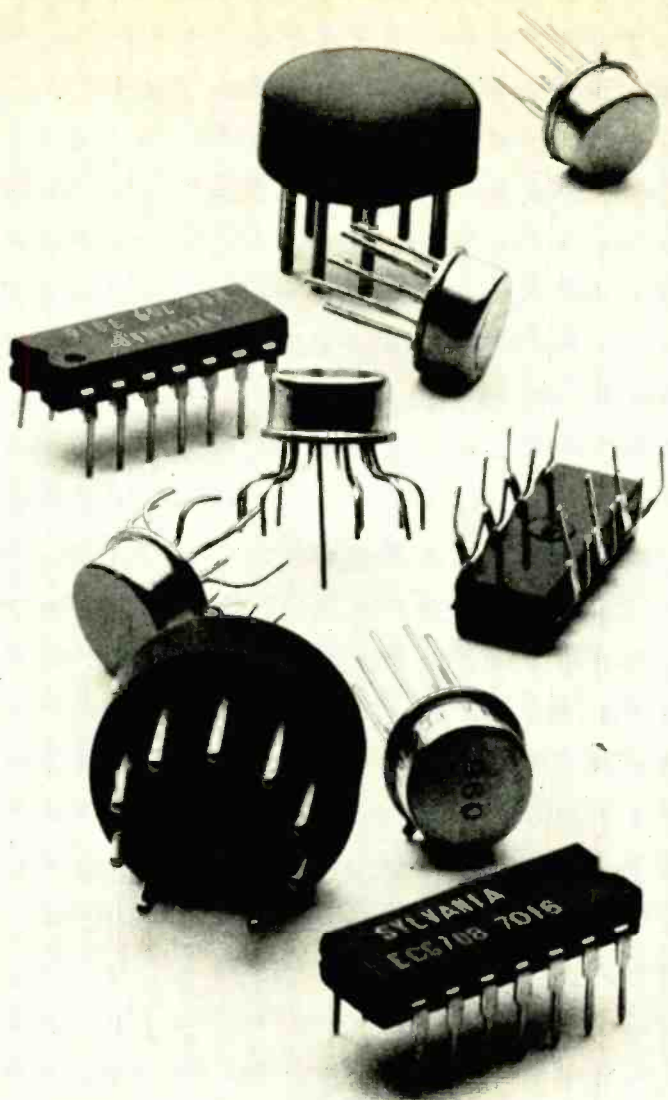

## Thirteen cures for 78 headaches.

Integrated circuits are replacing transistor circuits in many stereos, radios, B & W and color TVs.

That means more parts to stock and more money tied up in inventory.

Now, Sylvania ECG can take some of the pain out of these stocking headaches.

Our 13 ICs will replace 78 part numbers, including RF, IF and audio amplifiers, sound detectors, oscillator/mixers, chroma demodulators, and automatic fine-tuning systems.

That's 65 fewer items to stock.

And our 13 ICs are just part

of our ECG replacement line. That's the line that lets you replace 35,000 semiconductor types with just 87 Sylvania ECG types.

It's the line that lets you put a complete stockroom on one shelf.

Maybe the same shelf where you used to keep the aspirin.

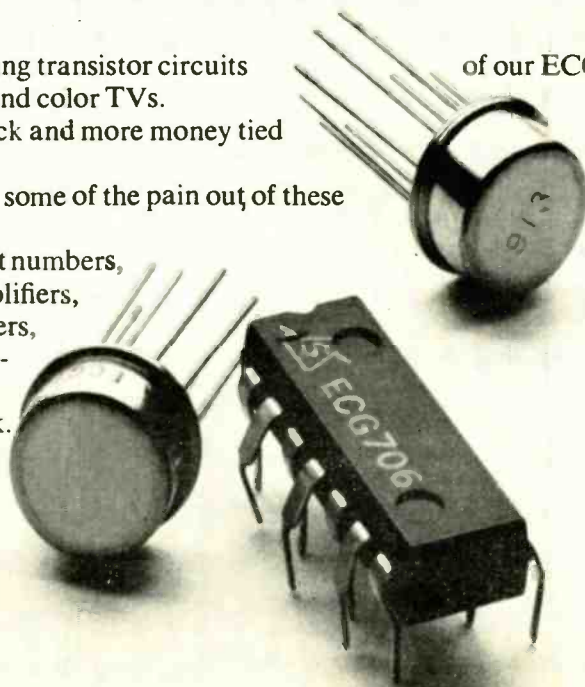

**SYLVANIA**  
GENERAL TELEPHONE & ELECTRONICS

**Hunting for a better job?**

**Here's the  
license  
you need  
to go after  
the big ones**

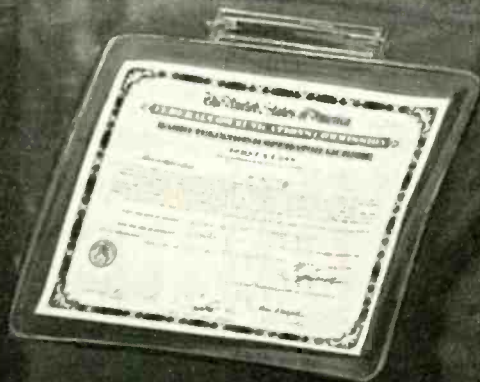



**A Government FCC License can help you bring home up to \$10,000, \$12,000, and more a year. Read how you can prepare for the license exam at home in your spare time—with a passing grade assured or your money back.**

**I**F YOU'RE OUT TO BAG A BETTER JOB in Electronics, you'd better have a Government FCC License. For you'll need it to track down the choicest, best-paying jobs that this booming field has to offer.

Right now there are 80,000 new openings every year for electronics specialists—jobs paying up to \$5, \$6, even \$7 an hour... \$200, \$225, \$250, a week... \$10,000, \$12,000, and up a year! You don't need a college education to make this kind of money in Electronics, or even a high school diploma.

But you *do* need knowledge, knowledge of electronics fundamentals. And there is only one nationally accepted method of measuring this knowledge... the licensing program of the FCC (Federal Communications Commission).

**Why a license is important**

An FCC License is a legal requirement if you want to become a Broadcast Engineer, or get into servicing any other kind of transmitting equipment—two-way mobile radios, microwave relay links, radar, etc. And even when it's not legally required, a license proves to the world that you understand the principles involved in *any* electronic device. Thus, an FCC "ticket" can open the doors to thousands of exciting, high-paying jobs in communications, radio and broadcasting, the aerospace program, industrial automation, and many other areas.

So why doesn't everyone who wants a good job in Electronics get an FCC License and start cleaning up?

The answer: it's not that simple. The government's licensing exam is tough. In fact, an average of two out of every three men who take the FCC exam fail.

There is one way, however, of being pretty certain that you will pass the FCC exam. And that is to take one of the FCC home study courses offered by Cleveland Institute of Electronics.

CIE courses are so effective that better than 9 out of 10 CIE graduates who take the exam pass it. That's why we can back our courses with this iron-clad Warranty: Upon completing one of our FCC courses, you must be able to pass the FCC exam and get your license—or you'll get your money back!

**They got their licenses and went on to better jobs**

The value of CIE training has been demonstrated time and again by the achievements of our thousands of successful students and graduates.

**2 NEW CIE CAREER COURSES**

**1. BROADCAST (Radio and TV) ENGINEERING...** now includes Video Systems, Monitors, FM Stereo Multiplex, Color Transmitter Operation.

**2. ELECTRONICS ENGINEERING...** covers steady-state and transient network theory, solid state physics and circuitry, pulse techniques, computer logic and mathematics through calculus. A college-level course for men already working in Electronics.

Ed Dulaney, Scottsbluff, Nebraska, for example, passed his 1st Class FCC License exam soon after completing his CIE training...and today is the proud owner of his own mobile radio sales and service business. "Now I manufacture my own two-way equipment," he writes, "with dealers who sell it in seven different states, and have seven full-time employees on my payroll."

Daniel J. Smithwick started his CIE training while in the service, and passed his 2nd Class exam soon after his discharge. Four months later, he reports, "I was promoted to manager of Bell Telephone at La Moure, N.D. This was a very fast promotion and a great deal of the credit goes to CIE."

Eugene Frost, Columbus, Ohio, was stuck in low-paying TV repair work before enrolling with CIE and earning his FCC License. Today, he's an inspector of major electronics systems for North American Aviation. "I'm working 8 hours a week less," says Mr. Frost, "and earning \$228 a month more."

**Send for FREE book**

If you'd like to succeed like these men, send for our FREE 24-page book "How To Get A Commercial FCC License." It tells you all about the FCC License... requirements for getting one... types of licenses available... how the exams are organized and what kinds of questions are asked... where and when the exams are held, and more.

With it you will also receive a second FREE book, "How To Succeed In Electronics." To get both books without cost or obligation, just mail the attached postpaid card. Or, if the card is missing, just mail the coupon below.

**ENROLL UNDER NEW G.I. BILL.** All CIE courses are available under the new G.I. Bill. If you served on active duty since Jan. 31, 1955, or are in service now, check box on reply card for complete details.

**CIE Cleveland Institute of Electronics**

1776 E.17th St., Cleveland, Ohio 44114

Accredited Member National Home Study Council  
A Leader in Electronics Training... Since 1934



**Cleveland Institute of Electronics**

1776 East 17th Street, Cleveland, Ohio 44114

Please send me without cost or obligation:

Your 44-page book "How to Succeed In Electronics" describing job opportunities in Electronics today, and how your courses can prepare me for them.

Your book on "How To Get A Commercial FCC License."

I am especially interested in:

- Electronics Technology
- Electronic Communications
- Broadcast Engineering
- Industrial Electronics
- First Class FCC License
- Electronics Engineering

Name \_\_\_\_\_

(PLEASE PRINT)

Address \_\_\_\_\_

City \_\_\_\_\_

State \_\_\_\_\_ Zip \_\_\_\_\_ Age \_\_\_\_\_

Check here for G.I. Bill information

RE-87

Circle 17 on reader service card

# SONY® achieves true integration

In all too many transistor integrated amplifiers, the preamp stage does not quite live up to the performance of the amplifier section.

Not in Sony's new TA-1130. Thanks to an FET front end, this integrated package has a preamp stage that really does full justice to its output section.

## Why FET's

For the same reason that we use them in our tuners and receivers, and in our studio professional condenser microphones; because FET's have a far wider dynamic range than ordinary transistor types.

And the preamplifier needs that range. Because it has to be sensitive enough to handle the lowest-output, moving-coil cartridges, yet still accept the highest output cartridges without overloading. (The power amp has it easier; you keep its input level fairly constant with your volume control.)

## Power to Spare

But if the power amplifier doesn't need that range, it does need power. The output section of TA-1130 has it: 230 IHF watts (into 4 ohms), with continuous power rated at 65+65 watts into 8 ohms. (With all that power, we made sure that both transistor and speaker protection circuits were included.)

## Nothing Stands Between You and the Sound

Both sections are powered by balanced positive and negative supply voltages (not just positive and ground), so there need be no coupling capacitors or interstage transformers between you and the sound.

Without them, the TA-1130 can extend its power band width down to 7 Hertz, and actually exceed its rated damping factor of 100 all the way down to 5 Hz.

## An Abundance of Audiophile Conveniences

Of course, the TA-1130 has all the control facilities that you could ask for: low and high filters, tape monitor, a speaker selector, and even an Auxiliary input jack on the front panel. The selector switch is Sony's instant-access knob-and-lever system.

There's even provision to use the TA-1130's power amp and preamp sections separately, to add equalizers, electronic cross-overs, or 4-channel adaptors to your system.

In fact, you can even get the power output section separately, as the model TA-3130 basic amp. It makes a great match for our TA-2000 preamp, too.

Your Sony dealer has both models available, and at prices—\$359.50 for the TA-1130; \$239.50 for the TA-3130. Sony Corporation of America, 47-47 Van Dam Street, Long Island City, New York 11101.



**SONY® F.E.T. Amplifier**

Circle 16 on reader service card





# THOSE REPLACEMENT TRANSISTORS: do they really work?

by JACK DARR  
SERVICE EDITOR

Finding a suitable transistor substitute is often quite a job. Here is a sure-fire way to find the transistor you need to get the set working again.

We used to think there were an awful lot of tubes. However, transistors make those long-tube-lists look like pretty small potatoes! I don't know how many tubes are on the entertainment-products lists, any more, but I saw a report a while ago, of a transistor list compiled in France. This claimed to show over 35,000 transistors! (I believe it! I believe it!)

As we all know, every time you open up a new set, you find a new batch of transistors. Only a very few companies, all of them U.S. firms, ever use the same transistors in different models. What you're going to find in import equipment is anybody's guess.

So, there's our biggest problem: finding suitable replacement transistors when one of the little 3-legged beasties goes out. And out they do go. Contrary to some of the early claims about the immortality of transistors, they probably provide the greatest amount of actual troubles, just as

their predecessors the tubes used to! And, here we are, faced with the problem of finding a replacement for a completely unknown "thing" sitting there in this amplifier stage, or whatever it is. What to do?

Fortunately for us, we're getting a lot of help from U.S. replacement transistor manufacturers. They go to the tremendous trouble of digging up data on these unknowns, checking them out against one of their standard units, and making up lists. They claim that a great many transistors can be replaced by a comparative few.

The question is, are they correct? To find out, in the place where they're used, on the service bench, we set up a project in RADIO-ELECTRONICS' Service Test Lab. Actual equipment was used, both U.S. and import. In many cases, actual repairs and replacement of defective transistors were made. These were actual failures, not artificially induced faults; real "in-the-field" transistor failures. Right now, before we go any further, we want to express our sincere thanks to Jack Jaques, of the HEP Division of Motorola Semiconductors, and R. A. (Bob) Nelson of RCA's Replacement Transistor Department, who gave us not only enthusiastic cooperation but a lot of invaluable advice.

During the course of this study, we could see a "method" gradually developing: one whereby the average technician could "do it himself." That is, with only a few simple tests and a Replacement Transistor Guidebook, select and install a replacement transistor that would do the work. I really believe that in the majority of cases, you'll be able to find some kind of identifying number on the transistor, and find it listed in the Transistor

Guide. If you have a schematic of the set, especially from a Sams Photofact folder, you'll find the replacement transistors in the parts lists.

With only a schematic, you can get a great deal of data: type, use, and so on. If voltages are given, this is very helpful. However, the start-from-scratch method we'll outline in a minute will help, even if you have absolutely nothing to start with.

### "Worst-case" method

Engineers, when they're designing something, talk about "worst-case" possibilities. What would happen to the circuit under the worst possible conditions. Let's start out with our versions of the worst possible conditions: We have a little import radio, and there are no names, markings or labels that will give us anything to go on. By main strength and awkwardness, and shotgun tests with our transistor-tester, we find that one of the transistors is bad. It has numbers on it, but they're meaningless; not in the replacement list. If that's not a worst-case, I hope I never see one!

So. What do we need? Information. Make up a little scratch-paper list as follows:

1. Maximum voltage? .....
2. Type (npn or pnp)? .....
3. How used (rf, af, i.f., etc.)? .....
4. Power rating (see text)? .....
- 4a. Case type (applies only to high-power audio and television sweeps)? .....
5. Germanium or silicon? .....

The first question is important; not as important as it used to be, but important. We must know the maximum voltage which will be applied to this transistor, so that we can pick a replacement that will stand up.

The second question is obvious; we have to have one of the same type, or it's not going to work too well! The third question is important mainly in tuned circuits: rf, i.f. and tuners. Audio transistors all have high-frequency cutoffs far above any we'll need. The power rating, in the 4th question, applies only to power transistors, such as audio outputs, and TV sweep transistors, vertical and horizontal. These do handle a good deal of power, and our replacement must have a safety factor big enough to take care of any future requirements.

The germanium or silicon question is important because of the difference in the cutoff bias; 0.2 volt for germanium, and 0.6 volt for silicon. Odd distortions, etc. can be due to the use of the wrong type transistor. (Oddly enough, they will interchange fairly well in *some* circuits! However, for best results, be sure you've got the right type.)

### The answers: How to get them

There are the questions: now, how do we get the answers? Easily: we test. 1. Voltage. If the thing is battery powered, fine. Look at the battery. This will give you the maximum voltage right away. Write that down.

If it is ac-powered, take the old transistor out, (See precautions on this, later on), turn the set on and read the dc voltage on the three empty holes. Or, read the maximum voltage delivered by the dc power supply. This can usually be easily identified by finding the power transformer, or the rectifiers, or, probably the best, the big filter capacitors. (You can get a rough idea by looking at the maximum voltage of the filter capacitors, if it's in English!) Write that down, too.

**CAUTION:** In some TV circuits, you may find transistors fed through very large resistors, or voltage divider circuits. If the transistor is completely open, or out of the circuit, voltages here may be high, because of the no-load condition; no transistor currents. In any case, if you use the higher voltage figure, you'll certainly be safer!

### What type is it, pnp or npn?

If your luck is running pretty good, you may be able to find another transistor with the same numbers, and check it. Your transistor-tester will give you the answer, in-circuit. If it's running about as usual, take the old transistor out. First, make a rough sketch of the PC board, and the transistor base. Figure 1 shows an example of this.

Since you don't know, as yet, which connection is which, sketch the transistor base upside down, and number the leads 1, 2, 3. If there is one junction of the transistor left working, you can find out the type.

If you can identify one lead of the transistor, this will be a big help. By turning the power on, with the transistor out of the board, you will

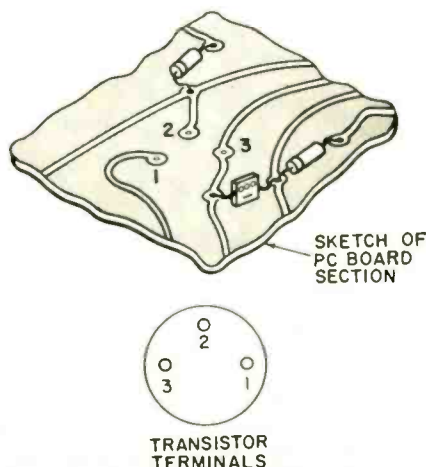

Fig. 1—SKETCH OF PC BOARD and transistor base. The numbers show corresponding leads and terminals.

normally find the highest voltage on the collector terminal. Most of the amplifier circuits will be common emitter; the collector will have the highest voltage, and the emitter will return to ground or common through a small resistor, a couple of hundred ohms. Identifying these two does the trick, since only the base is left.

In this circuit, the collector is always reverse-biased. So, the collector of a pnp would have a high *negative* voltage, an npn a high *positive* voltage. The emitter terminal will be zero, if the transistor is out. The base may have a voltage-divider network to set bias, but if so, this will be much lower than the collector voltage.

The preceding applies mostly to small-signal transistors, such as rf, i.f. and audio preamplifier transistors. In power stages, such as audio output, and driver stages, you may find the collector going to ground through a transformer winding, with the highest voltage applied (in reverse polarity) to the emitter. This kind of circuit will usually be pretty obvious: you will be able to see the terminals going to the audio transformer. Figure 2 shows examples of these two circuits.

As you can see in the i.f. stage circuit (Fig. 2-a), if this transistor was out, you'd read a  $-11$  to  $-12$  volts on the collector terminal, still read  $-1.4$  volts on the base, and zero on the emitter. In the audio driver circuit (Fig. 2-b), you'd read zero on the collector, since this goes to ground through the low-resistance primary of the

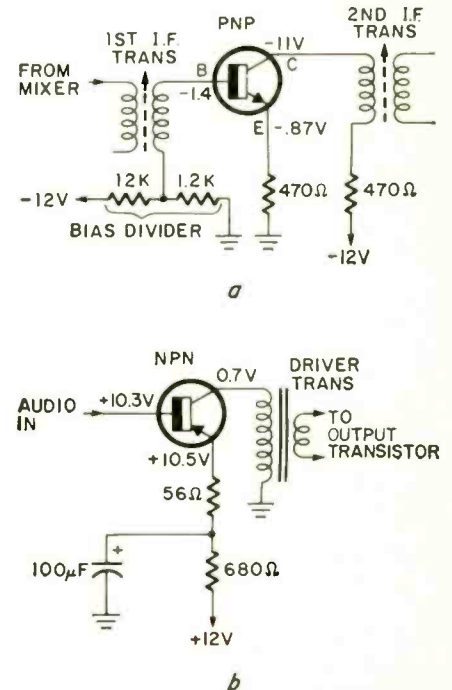

Fig. 2-a—I.F. AMPLIFIER using pnp transistor in common-emitter circuit. b—Audio driver using npn transistor in a common-emitter arrangement. Although the collector is grounded through the transformer primary winding, the circuit is still a common-emitter type.



th sformer, the full +12 volts on th itter terminal, and probably read the full supply voltage on the base.

In the case of the i.f. transistor, the negative polarity on the collector would tell you that this is a pnp. In the audio driver circuit, the element going to ground through the transformer winding is almost certain to be the collector, since this circuit is used quite frequently. (The signal is taken off the emitter only in emitter followers, and usually through a capacitor.) The positive polarity on the emitter and base tells you that this is an npn. The collector is biased "more negative" than the emitter.

**Playing the percentages**

Like all other methods, this isn't 100%, or "universal." However, it will work in most cases. All it takes is a careful testing of the circuit, and then applying logic to the results.

This is easier than it sounds; you can do things like finding a transistor sitting between two i.f. transformer cans, and saying that it is an i.f. amplifier! Trace other components; for example, if you can see a good sized capacitor, connected from the slider of the volume control straight to one of the elements of a transistor, you can pretty well figure that this is an audio transistor, and the capacitor goes to its base!

Use any other simple tests that you can think of. There are a lot of them. For example, turn the set on, and check on all three elements with a scope. See what *kind* of signals you get. With the transistor out of the circuit, if you find signals on only one element, the chances are very high that this is the *base*. Even older narrow-band scopes will tell you the difference between audio, rf, and/or sync signals, or video signals. Once you can identify that base connection, the ohmmeter tests will usually give you the others, together with the voltage readings. (In other words, if you have the base, there are only two left; the one on the board with the highest voltage will probably be the collector.)

Next question; is this stage a common-emitter, with the highest voltage on the collector, or a grounded-collector common-emitter, with the highest voltage on the emitter? To identify these, check for the *signal-transfer* device: the transformer winding, or coupling capacitor. If the collector goes to ground through a transformer winding, or through a resistor with a coupling capacitor connected directly to the collector, then it is a grounded-collector type. The highest voltage will then be on the

emitter. Confirm; there will be an emitter bypass capacitor, a fairly large one, directly from the emitter to *ground*. Alternate, in a very few circuits: there will be a smaller resistor on the emitter, unbypassed for degenerative feedback, but there will be no signal-transfer device.

**Common Basings**

There will be two major types of cases or packages for small-signal transistors: one is the TO-5 (round metal) case, with three leads, as at *a* in Figure 3. Looking at the bottom of

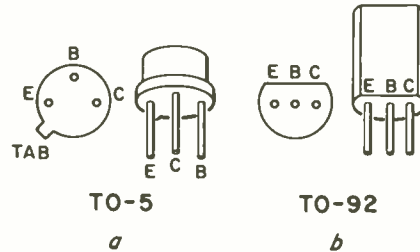

**Fig. 3—SMALL-SIGNAL TRANSISTORS often use the TO-5 (a) or TO-92 (b) base or terminal configurations.**

these, start with the first lead to the left of the little locator tab. The majority of these now seem to use the "E-B-C" basing, going clockwise around from the tab. A few will use the "E-C-B" basing, as at the right.

The very small epoxy-case transistors, with one flat side, in the TO-92 case, mostly use the "E-B-C" basing as shown at left. A good many of these will have the letters stamped into the case, as shown at the right, but they'll be small. You may have to use a magnifying glass to find 'em, but try it! It might be well worthwhile. These, and all other transistor base diagrams, can be found in the transistor Replacement Guides, either in the front or back of the book.

**The finished list**

If you've written this data down as you got it, by now you should have a pretty good list of the characteristics you need for the replacement transistor. Let's plug in some figures to see what it might look like. Say the transistor has 25 volts applied to the collector, it's an npn, and was in the second i.f. stage of a 40-MHz i.f. TV set. Fig. 4 shows what the list might look

Voltage ..... +25 V...  
 40-MHz i.f. .... 50 MHz...  
 Basing ..... TO-92...  
 Germanium or silicon .Si.

**Fig. 4—MAKE CHARACTERISTICS LIST and fill in pertinent information.**

like as you add known information.

NOW we start looking through the characteristics listings in our transistor replacement guide books. All of these give this information, either in the front or the back of the book. First we look for silicon npn's. These are usually separated into classes, like this. We find a Motorola HEP-736; 50 volts collector-emitter breakdown, so that's fine. 600 mA dc maximum collector current, 310 milliwatts dissipation, and the frequency cutoff is 150 MHz. That'll do nicely. RCA's book shows an SK-3018, Silicon npn, collector-emitter voltage breakdown rating of 45 volts, 180 mW dissipation. Upper-frequency cutoff which isn't given. However, this transistor is rated for "rf, mixer and oscillator stages, i.f. stages and for vhf TV," so that's fine.

So, there you are. That's the whole ball of wax. Notice that we did NOT mention the basing of the replacement transistor? This is the least important of all. As long as we know the basing of the new transistor, we can get it hooked up! Even if the original base is E-C-B, and the new one is E-B-C, we can put a tiny piece of spaghetti on the base lead, and put it in "cross-legged" to get the leads into the right holes. Figure 5.

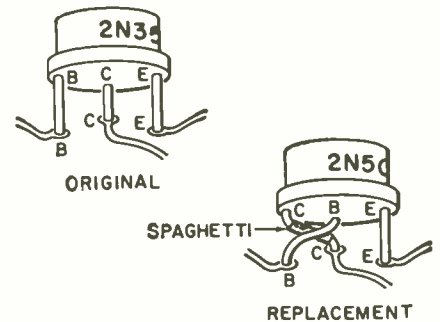

**Fig. 5—HOW TO MOUNT TRANSISTORS when original and replacement units have different terminal lead arrangements. Spaghetti prevents shorts.**

There are quite a few other replacement transistors that will fit the specs here. We chose these two to explain the basic method, and because they are so widely available.

**Medium power transistors**

You'll find stacked and complementary-symmetry output circuits used in a great many mono and stereo amplifiers. The "output-transformerless" circuit (OTL) used with these saves a lot of bulk (and parts!) The use of the complementary-symmetry circuit, with one pnp and one npn transistor, saves having to use a phase-inverter.

Transistors in the smaller units up to 5 watts will often be the small types in TO-5 cases. There are a lot of

these. In ac-powered equipment, voltages will be higher, so now you have to watch out for that, too. A typical replacement pair would be something like Motorola's HEP-242, a silicon npn, and HEP-243, silicon npn; rated at 60 volts at 3.0 amperes. RCA's SK-3024 is a silicon npn, and its complement is an SK-3925, npn. These are rated at 5 watts, with a 120-volt collector breakdown and a 1.0 ampere current.

For the "quasi-complementary pair," using two identical transistors, you can get matched-pairs. RCA's SK-3037 is a matched pair of SK-3036 transistors, silicon npn with 90 volt breakdown, and a total rating of 150 watts *each*. There are several others. You can match these pretty well with your transistor tester, if you can't find one in stock, which is unlikely. To get a definite check, read the collector currents, after installation. These should be very close.

A lot of these small transistors will have slip-on aluminum heat-sinks. Be sure to replace these. Others will have flat-plate type clamp-on heat sinks. Another type will clamp all of the output transistors to the chassis. In most cases, the cases (collectors) of the transistors must be insulated from chassis. If you have any doubt about the insulation, replace it!

Some of the later stereos, and a lot of auto-radios, will use the newer flat-case (case -77), power transistors, with a flat epoxy case and long extended leads. Typical examples of this type are RCA's SK-3041, silicon npn, and Motorola HEP-245, silicon npn. There is a complement for this, in the HEP-246, silicon pnp, for matched pairs in comp-symm outputs. The collector of these transistors is connected to the case; actually, to a bare metal area around the mounting-bolt hole. If this must be insulated, shoulder-washers and flat mica washers are needed. These will generally be packed with the new transistor. In auto-radios, the heat-sink itself is often insulated, with the transistors bolted directly to it.

### High power transistors

Now we come to a little different class; the really high powered jobs. Easier in some ways, harder in others. As far as classification is concerned, audio output, TV horizontal and vertical sweep output transistors will all fall into the same class.

Beside the voltage rating, now you will have to watch the maximum current rating very closely. In auto-radio and b/w TV sweeps, this will be somewhere around 1.0 ampere actual drain. Power dissipation will be around 5 watts, as a ball-park figure.

In auto-radios and small mono or stereo amplifiers, your maximum voltage will be about 14 (the voltage found in a car with the engine running). In medium-power stereo amplifiers, it can be higher, up to 40-50 volts; check the dc power supply.

So, if you need one of these, check your replacement lists for a transistor in the same case, with plenty of voltage-breakdown rating; 25 volts for auto-radios, and about 20% over maximum voltage for the ac-powered circuits. From this point on up, you'll find most of the power transistors in the TO-3 cases, or the TO-41, which is the same. The popular auto-tape players use a lot of the TO-66 case types; these are the same shape as the TO-3, but smaller. Here, too, you'll have a wide range of choices in the different lines.

### Power transistor mountings

One very important thing about these transistors is mounting and heat-sinking. Now, we're dissipating a much greater amount of power, which must be carried away by the heat-sink. You may have heard the fable about "Transistors running cool." Have you ever touched a hard-working output transistor under full load? If you don't have thick callouses on your fingertip, I wouldn't recommend it! You can fry eggs on some of them. (Small eggs, of course!) So, the heat-sink is a very important part.

Most of them will have an integral heat-sink, either as a part of the radio case, or the chassis, in amplifiers. In practically all of these transistors, the collector is electrically connected to the case, for better "thermal connection" to dissipate the heat. They'll also have to be insulated, since the two collectors are seldom at the same voltage.

Be SURE to check, before you take the old transistor out, so that you'll know how it was mounted, and whether it was insulated or not, and how. It's always a good idea to coat

both the underside of the transistor, and the new mica washer, with silicon grease, to improve the thermal coupling to the heat-sink. If a new mica washer is included in the mounting kit, use it; practically all replacement transistors provide new washers. After the transistor is mounted, check from case to ground with an ohmmeter, to make SURE that you do not have an accidental short. Leave the base and emitter leads off until this is done. If the case is grounded, and you turn it on, you may have two bad transistors; the old one, and the new one you just installed. (Don't ask me how I know.)

### Darlington pair transistors

A special circuit has gotten very popular in the last year or so. This is one that can cause you a lot of trouble if you don't know about it! It looks like a standard transistor, in a small flat-sided epoxy case or a TO-5 can. However, it isn't! It's a two-stage, direct coupled amplifier circuit, called a *Darlington pair*. Figure 6 shows the

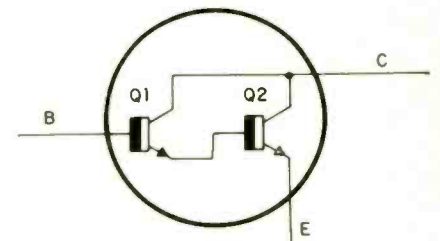

Fig. 6—INSIDE THE DARLINGTON PAIR composite transistors.

internal connections. Only three connections are brought out, and it does look exactly like a stock preamplifier transistor.

The circuit itself isn't new. It's been used for quite a while. Here's how it works. Transistor Q1 is connected as an emitter follower. Its characteristics are high current gain, low voltage gain and high input impedance. It is directly coupled, emitter-to-base, to transistor Q2.

(to be continued)

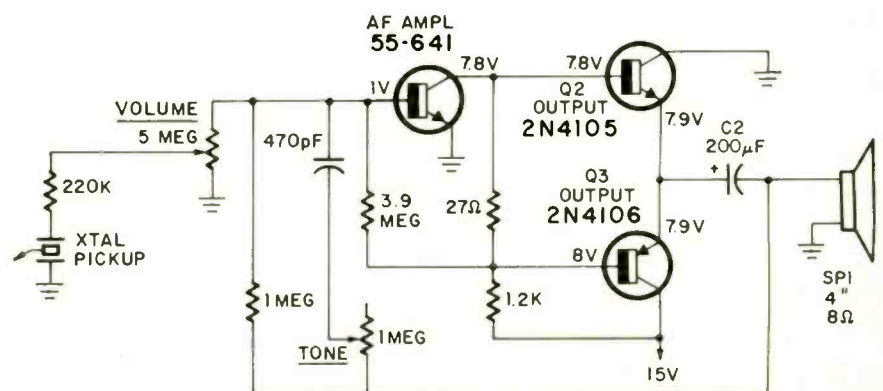

Fig. 7—DARLINGTON-PAIR is shown as a single transistor in some schematics as in service data for Truetone 4DC6963.





# Build One-IC Audio Generator

*High-quality low-cost generator covers 20 Hz to 20 kHz in three bands. It's easy to build and very handy to have around the shop.*

by R. D. CRAWFORD

LINEAR INTEGRATED CIRCUITS ARE coming into style in a big way, and for good reasons. The present generation of operational amplifiers, for instance, has features that lend themselves to the design of audio equipment. These features include:

1. Well controlled gain and phase characteristics.
2. Short-circuit proof,
3. High gain,
4. High input impedance,
5. Reasonable price.

An excellent application for these IC's is the audio oscillator described here. It covers the audio range from 20 Hz to 20 kHz with less than 1% distortion and is very simple.

The circuit (see Fig. 1) is derived

### PARTS LIST

- R1, R4—2400 ohms, 2%, 1/4 watt  
 R2, R3—ganged pot, 25,000 ohms each section, linear taper  
 R5, R6, R7—pot, 200 ohms, 1/4 watt  
 R8—pot, 10,000 ohms, audio taper  
 R10, R11—10,000 ohms, 10%, 1/2 watt  
 C1—.0012  $\mu$ F, 200 V, Mylar, 10%  
 C2—.012  $\mu$ F, 200 V, Mylar, 10%  
 C3—.012  $\mu$ F, 200 V, Mylar, 10%  
 C4—1.0  $\mu$ F, 35 V, tantalum, 20%  
 C5—.01  $\mu$ F, 200 V, Mylar, 10%  
 C6—.01  $\mu$ F, 200 V, Mylar, 10%  
 C7—5  $\mu$ F, 50 V, electrolytic  
 C8, C9—200  $\mu$ F, 25 V, electrolytic  
 C10, C11—.01  $\mu$ F, 100 V  
 D1, D2, D3, D4—1N3253 (500 mA, 200 prv, silicon)  
 D5, D6—1N5246 (16 V Zener) 10%  
 IC1— $\mu$ A741C or equivalent (Fairchild)  
 Q1—2N3053  
 Q2—2N4037  
 F1—1/4 A slow blow  
 S1—3-pole 3-position shorting (Centralab 1008 or equiv)  
 S2—spst, 3A  
 T1—117V pri; 32V ct sec. (Triad F-90X or equal)  
 LM1—10V, 14 mA (344, 1869, 914) or 10V, 10mA (913,367)  
 LM2—Neon panel lamp and resistor assembly

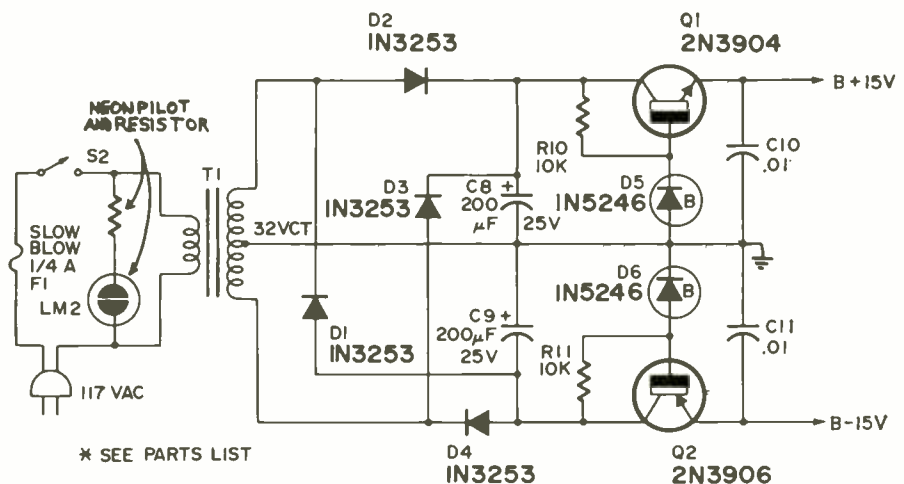
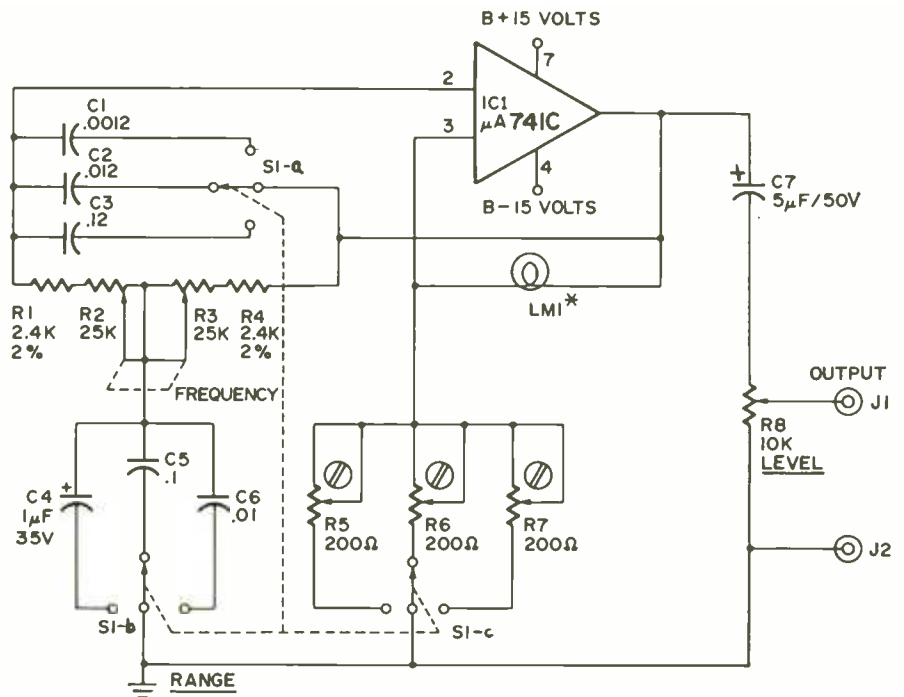

FIG. 1—HERE'S THE CIRCUIT of the generator (a) and its power supply (b).

from the bridged-T R-C oscillator used in so many vacuum tube audio oscillators. This circuit has a greater Q than a Wien bridge circuit. To adapt it for integrated circuits, a ganged potentiometer is used as the tuning element instead of a ganged variable capacitor. This gives a tuning dial with almost 360 degrees rotation. Another advantage of the potentiometer tuning is that the oscillator is insensitive to 60-Hz hum, a common problem with R-C oscillators. My unit

displays no visible beating effects when tuned near 60 Hz, and it won't lock to 60 Hz.

The integrated circuit used is a 741C. About the only way to damage it, is to plug it in backwards. Fairchild introduced this microcircuit, but several companies are now producing it.

Lamps for the feedback circuit are sometimes a problem with R-C oscillators, but there are several that can be used with this design (see parts list). The curves for frequency re-

sponse and distortion were taken using a 10-volt 14-mA lamp, but a 10-volt 10-mA lamp can be used. The latter lamp will give slightly lower distortion above 100 Hz and slightly higher distortion below that. Treat these lamps carefully; the filaments are fragile.

The frequency response curves (Fig. 2) show great similarity from band to band. Actually this shows the tracking of the two sections of the tuning potentiometer. The output on mine was within 2 dB of 1000 Hz. I suggest using a high-quality potentiometer, as this will result in good tracking and thus a flatter frequency response. The frequency response is the same for all outputs between 2 and 4 volts.

The distortion curves are shown in Fig. 3. In general, distortion at 2 volts output will be less than at 4 volts output, but not by much. The distortion rise at low frequencies is due to the lamp changing resistance during each cycle. This gives rise to odd order (mostly third) harmonic distortion. At the higher frequencies, the distortion starts increasing because of the decreasing loop gain of the IC at these frequencies. The third-harmonic distortion starts rising above 5 kHz because of slew rate limitations of the IC. However, the distortion never exceeds 1%, and over most of the audio range it is 0.1% or less. Thus at 1 kHz this generator is a useful unit for harmonic distortion testing of audio amplifiers.

The power supply is straightforward. The current drain of the 741C is less than 5 mA unless a low impedance load is placed across the output. Then the output current (and power supply current) is limited to 20 mA, so a smaller transformer can be used if desired.

Adjusting the finished unit is easy. Turn on the generator and check power supply voltages. Set the frequency dial around midscale, set the range switch to  $\times 1$ , and adjust R5 for the desired output amplitude. Repeat with R6 and R7 for the other two ranges. The dial can be calibrated on the  $\times 1$  range using Lissajous patterns, or with a frequency counter if you're fortunate enough to have access to one.

There you have it, a good quality low-cost audio oscillator that will introduce you to working with linear integrated circuits. **R-E**

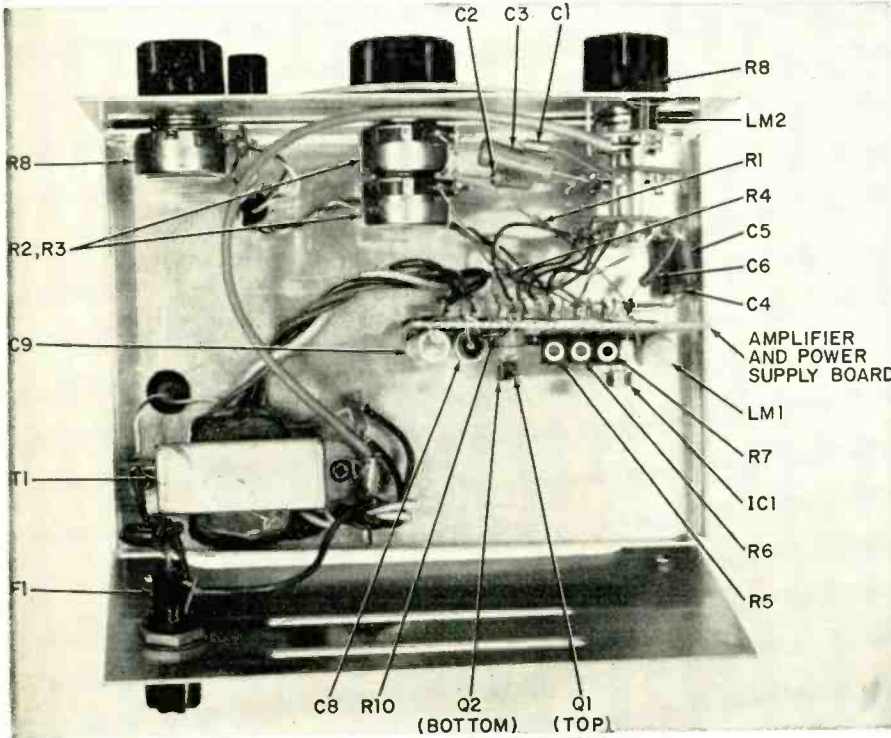

**INTERNAL VIEW** of the completed unit. Part locations are identified to simplify construction.

**FIG. 2—FREQUENCY** response curves are good thanks to close potentiometer tracking for R2 and R3.

**FIG. 3—DISTOR-** TION curves show that it never climbs above 1% and is below 0.1% for most points.

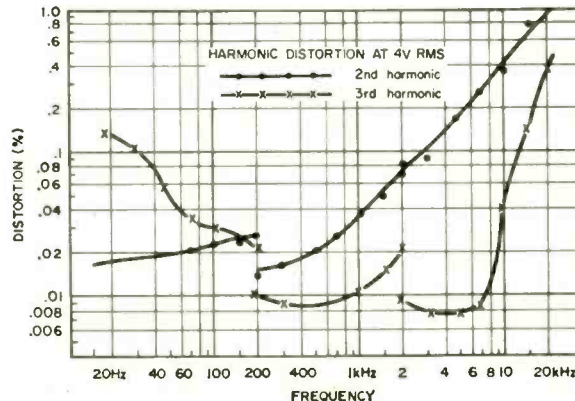
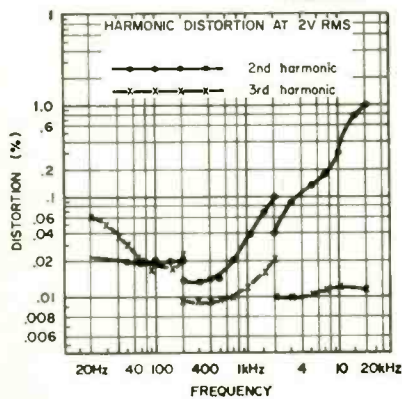
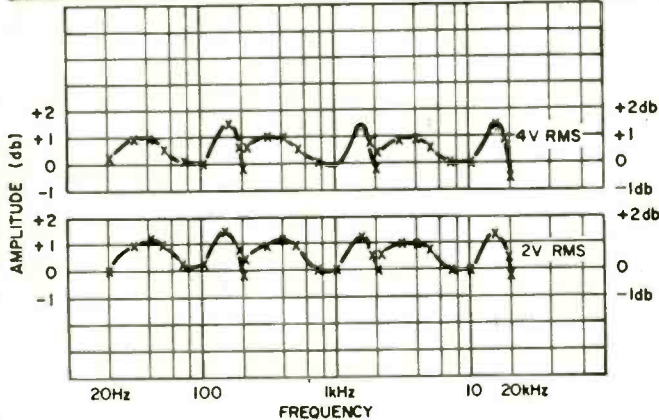



# ENGINEERS & DOCTORS— A NEW PARTNERSHIP

by PHILIP REICHERT, M.D.\*

THERE'S A NEW TEAM IN MEDICINE and public health, a new department in medical schools, a new word in the language. The doctors and the electronics experts have joined forces in *Bio-Medical Engineering*, and the things they are doing are rapidly turning science fiction into fact. Each month, each week, contributes reports of body functions helped or even taken over by transistors, implants . . . the list grows even as I write about it. The integrated circuits get smaller until they almost disappear; the miniatures get into the heart and blood vessels, even into the brain.

You must keep up with it or fall far behind. The blind man's radar cane is already old hat: the new report from Mexico is the *amauroscope*. Goggles pick up luminous images in photo-electric cells and transmit the electric impulses to electrodes placed on the nerve just above each eye, and the stimulation goes to visual receptor centers in the brain. Blind people walk around obstacles and they no longer need a cane, not even a radar cane. But don't rush out to get an amauroscope, yet. Next month there may be something better. The engineers are working on it with the doctors' help.

There are any number of research and development units trying to "conquer the dark". Many are commercial and some are non-profit, but all are hot on the trail of devices that use the latest electronic equipment and the boldest invasion of the body's nerve receptors. The Braille raised code is read by scanners, and work is in progress to make scanners that will read ordinary type. This, of course, right now is far from easy, but far from impossible.

The blend are in the arts and in science. There is a whole library of text books recorded on tape. Anatomical diagrams are carefully described by volunteer specialists and the blind are in medical schools, in chemistry, in engineering. The need to be self supporting has important psychological overtones, and there is job training in the use of business and technical equipment.

Hearing aids have progressed from the cumbersome boxes to the tiny aid that is completely concealed inside the ear canal—the microphone, the amplifier, the receiver and the bat-

tery—the whole works the size of a pencil eraser, hidden. The amplifying stethoscope for the hard-of-hearing doctor had the unexpected advantage of bringing out heart sounds that had previously been missed by doctors who thought their hearing perfect.

Graphic methods have been the goal of medical investigators for years: the first electrocardiographs were the size of a bath tub and expensive beyond the reach of most physicians. The thermionic tube sets made them smaller and cheaper, and the solid state came next, again smaller and less costly. During the last ten years there have been two great contributions of the engineers to medicine—telemetry and monitoring.

*Telemetry* has made possible the transmission of physiological data not only across land and sea, but also across thousands of miles in space. The space shots and moon shots were made possible. *Monitoring* a continuous record of heart rate, respiration, and blood pressure has been adapted to another important and life saving set-up, hospital intensive care units.

The heart specialists have made particular demands on their engineering associates. The patient with coronary closure, in imminent danger of sudden death through heart stoppage, is kept under continuous electrical surveillance. Any change in rate or rhythm that spells danger sounds an alarm and brings instant help. This help again is sometimes electronic. It may be an electrical shock to restore regularity of beat, or to restore a beat that has stopped entirely.

Where the normal mechanism for heart beat has failed, it is possible to implant a *pace-maker* connected into the heart muscle. This battery-powered unit will keep up a continuous series of electrical impulses to stimulate the heart beat. The whole unit is smaller than a book of matches, completely self-contained, sealed into the chest wall surgically.

The veterinarians have used a sexual stimulator to cause ejaculation of semen in a bull. Frozen and shipped by air, a prize bull has been used to impregnate hundreds of cows many miles away. This method may not be popular with humans, but it may be on the way, especially where paralysis makes normal intercourse impossible and where children are desired.

Paralysis of limbs may now be helped. A contact button in the heel may shoot a stimulus to a weakened leg, or even to an artificial leg. A

whole project is under way to make artificial arms and legs obey commands of action from the brain. Amputees are working with the bio-engineering team of a great university rehabilitation center. They have built an arm that is operated by the thought processes of the human brain. Electrodes implanted in residual muscles transmit commands that the artificial arm obeys. After a retraining period the operation of the prosthetic limb will be as smooth and rhythmic, almost, as the original limb.

The most dramatic development, so far, has been the control of emotion and of resultant behavior. The mapping of the brain has been a continuous process for years and the specific areas that control specific functions are fairly well known. That the brain in action gives off electrical waves has been the basis of the electroencephalographic studies that have been extensively reported. More recently, implanted electrodes in the brains of monkeys have been experimented with, and the results have shown control methods that could be applied to human problems.

One report concerns a lad of eleven who had uncontrollable epileptic seizures and destructive behavior. In an attempt to use a surgical approach, electrodes were implanted in the boy's brain for the purpose of pin-pointing the areas affected by the seizures. During the several days of observation, it was noted that the electrical stimulation of one certain area markedly increased the boy's friendly attitude, reduced the destructive pattern of his behavior, increased his conversational capacity and pin-pointed the exact area of his brain from which the seizures came. The new team has actually begun to find a way electrically to influence the physiological basis of the human mind.

The horizon expands with no limit in sight. This is only a partial listing of what is already in the works. The new team of bio-medical engineers has the goal of applying the entire spectrum of the physical sciences to the service of the medical profession. The very word "rehabilitation" takes on a new impressive dimension: for the blind, the deaf, the paralyzed, the amputees, the cardiac facing sudden death, the epileptic, the childless, and now even the aggressive and compulsive criminal. We have come a far way from the ancient Physician-priest who cast out devils by incantation and by chants. We have come full circle to the bio-medical engineer with the new magic of electronics, a weird complexity of wires, transistors, tiny implants—all to bring new hope and help to the disabled and the sick. **R-E**

\*Sometime fellow of the Rockefeller Institute for Medical Research and executive director emeritus of the American College of Cardiology.



# BUILD

FRONT PANEL of the darkroom thermometer is plain and simple. Dial is calibrated in degrees for easy reading.

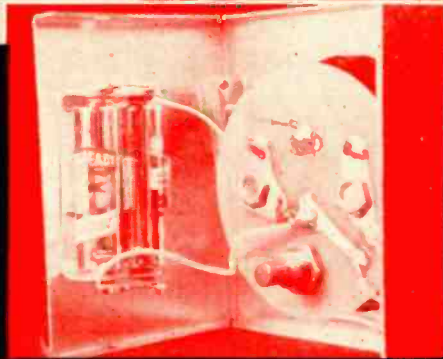

INSIDE VIEW of the author's monitor.



CIRCULAR CUTOUT for the meter is easy if you first drill holes for metal cutter.



PROBE WIRE is enclosed in plastic (tygon) to protect the wires and the thermistor.



# an electronic darkroom temperature monitor

*A handful of electronic components go together to make this really-accurate fast-reading thermometer*

by JAMES A. GUPTON, JR.

WHEN WAS THE LAST TIME YOU MEASURED a temperature? That bout with the flu? Troubleshooting an overheating electronic component? Processing a roll of film? In any case, you probably used a mercury-bulb thermometer.

Unfortunately, the mercury-bulb thermometer has drawbacks. It requires as long as 5 minutes for the mercury to stabilize. Next, the scale is difficult to read, even in normal room light. In the dimness of a photographic darkroom the scale can become impossible to read. Fractions of a degree must be estimated. Finally,

the thermometer is made of glass, which can break and scatter glass fragments and mercury droplets everywhere.

### Thermistor circuit advantages

Of the many mechanical or electronic devices used for measuring temperature, the thermistor is most widely used. For temperatures under 300°F, the thermistor circuit can be  $\pm 0.001^\circ$  accurate, yet contain no more than six components.

The basic thermistor circuit is in Fig. 1. It requires only a voltage source, a meter and the thermistor. As temperature varies, the thermistor resistance changes and the current

change through the meter is calibrated in temperature units.

This means versatility in measuring temperatures, since the thermistor can be placed any distance from the meter circuit. The thermistor's high resistance makes ambient temperature changes in the connecting copper wires to the probe negligible.

Before assembling a thermistor temperature monitor, two points must be determined: the temperature range to be measured and the accuracy required. For general photographic temperatures used in black and white processing, we need an accuracy of  $\pm 2^\circ\text{F}$  ( $\pm 1^\circ\text{C}$ ). For color processing or printing, accuracy must be  $\pm 0.5^\circ\text{F}$

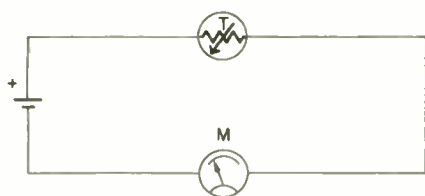

FIG. 1.—BASIC THERMISTOR CIRCUIT indicates temperature changes on meter.

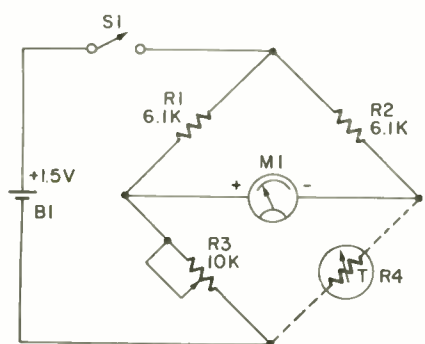

FIG. 2.—TEMPERATURE MONITOR circuit used in prototype. R3 is set to the lowest temperature resistance of the thermistor.

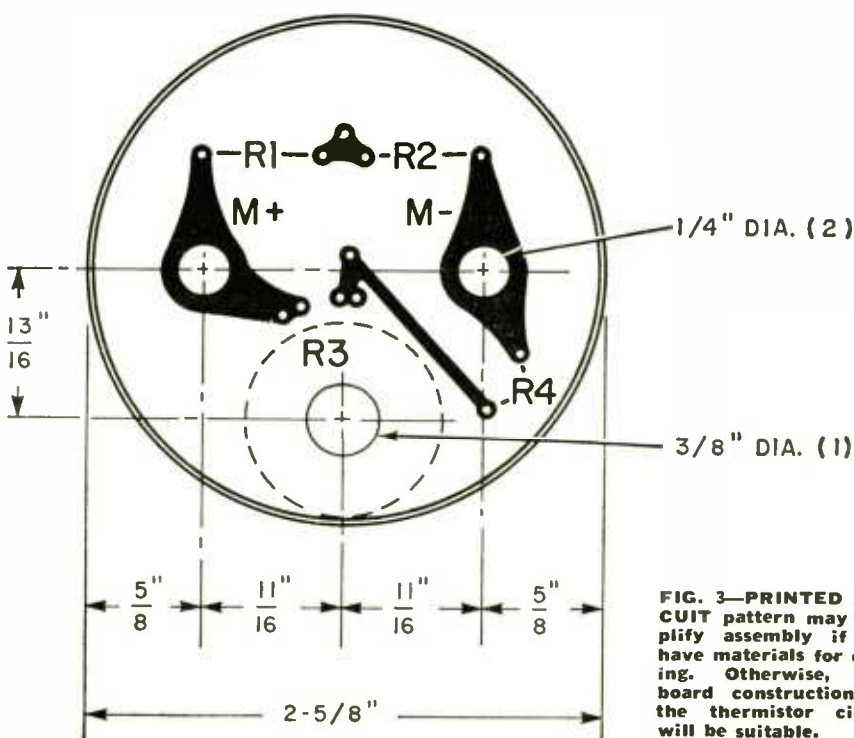

FIG. 3.—PRINTED CIRCUIT pattern may simplify assembly if you have materials for etching. Otherwise, perf board construction for the thermistor circuit will be suitable.

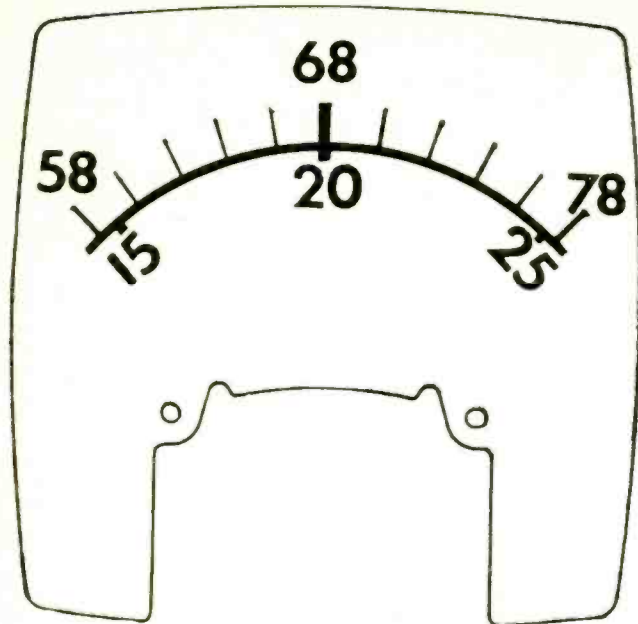

FIG. 4—METER FACE for use with specified meter indicates film-processing temperatures.

( $\pm 0.25^\circ\text{C}$ ).

Thus temperature requirements vary from  $68^\circ\text{F}$  ( $20^\circ\text{C}$ ) to  $78^\circ\text{F}$  ( $26^\circ\text{C}$ ) for slide or negative film processing and  $75^\circ\text{F}$  ( $25^\circ\text{C}$ ) to  $100^\circ\text{F}$  ( $38^\circ\text{C}$ ) for color print processing, according to the process used. Although thermistors can easily cover both temperature ranges accurately, the values of R1 and R2 must be changed from film-temperature values to printing values for accurate readings.

The resistance of R1 and R2 should equal the thermistor value at the mid-point of the temperature to be measured. Resistor R3 should equal the lowest-temperature resistance thermistor at the bridge null-current point. Since the meter scale determines accuracy, a microampere meter is the most suitable for extreme accuracy. Only  $2^\circ\text{F}$  will take one division on a  $20\text{-}\mu\text{A}$  meter scale; this can easily be scaled to tenths of a degree.

A small printed-circuit board simplifies mounting the resistors directly to the meter terminals. Fig. 3 provides both physical measurements and circuit layout for the meter specified. Adjust the dimensions slightly so meter terminal holes fit the meter you use. The idea is to make the PC board diameter the same as the meter body. If it's oversize, you'll have a problem getting the assembly into the cabinet meter hole.

Drill wire or resistor holes with a No. 55 drill bit or 0.052-inch diameter bit. For the potentiometer lugs simply drill three No. 55 holes very close together and angle the drill to work out the interconnecting material. You might try mounting the battery box on the chassis wall with double-sided adhesive tape. I use Kleen-Stick pressure-sensitive transfer adhesive (No. 202-1DP).

Since the thermistor is to be used at a remote position, the R4 terminals are wired to a phono socket. In the prototype model, the thermistor is connected to a pair of thermocouple connector wires and enclosed in a section of  $\frac{1}{8}$ -inch plastic tubing. The tubing keeps chemicals from the connecting wires and protects the thermistor from breakage. A switch is wired in the battery supply line for on-off operation.

#### How to calibrate

When assembly is completed, turn on the battery switch and hold the thermistor between your fingers. If the meter begins to deflect counterclockwise, reverse the battery polarity. I set the prototype for  $68^\circ\text{F}$  at mid-scale on a  $0\text{-}20\text{-}\mu\text{A}$  meter. With a laboratory-grade mercury-bulb thermometer, I began calibration at  $58^\circ\text{F}$  and progressed upward to full scale in  $1^\circ\text{C}$  sets. On my meter, the null point is  $14.4^\circ\text{C}$  or  $58^\circ\text{F}$ ; mid-point is  $20^\circ\text{C}$  or  $68^\circ\text{F}$ ; full scale is  $25.6^\circ\text{C}$  or  $78^\circ\text{F}$ . Fig. 4 shows a meter face that provides  $2^\circ\text{F}$  increment steps from  $58^\circ$  to  $78^\circ$ —the range of film processing temperatures for both color and black and white.

#### PARTS LIST

R1, R2—6,100-ohm,  $\frac{1}{2}\text{W}$ , 5% resistor  
 R3—10,000-ohm linear potentiometer  
 R4—thermistor (Fenwal GB35P8 or equiv)  
 M1— $0\text{-}20\text{-}\mu\text{A}$  meter (GE D0-91 or equiv)  
 S1—spst switch  
 B1—1.5-volt Penlight battery (2 in parallel)  
 MISC—4 x 5 x 3-inch utility box, plastic tubing, phono plug and jack, battery holder

For additional information on thermistors and thermistor circuits, I recommend Thermistor Manual EMC-5, available from Fenwal Electronics Inc., Framingham, Mass. 01701. They will furnish thermistor data on request. **R-E**

## STEREO SPEAKER HEADPHONE SWITCHING

The usual headphone-loudspeaker switching circuit switches the "hot" lead from the headphone to the loudspeaker depending on which is desired. This type of switching circuit is difficult to implement if the loudspeaker and headphone are of different impedances and must be rewired if the loudspeaker impedance is changed.

This circuit switches the ground lead and has some very useful advantages. It is only suitable for amplifiers whose two channels have a common ground. The particular values shown work well with a Dyna Stereo 70 and Koss Pro 4-A headphones. With this

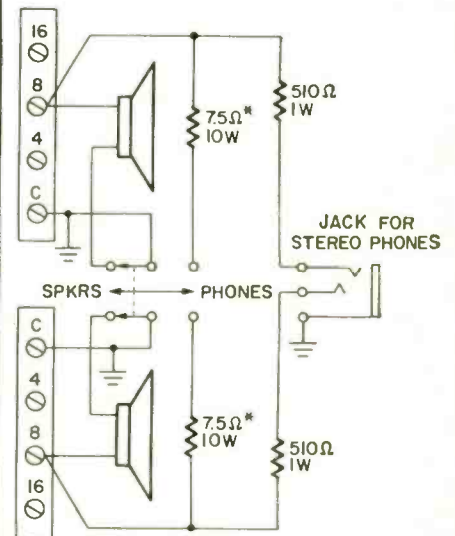

\* FUSED RESISTOR (RADIO SHACK NO. 271-147 OR EQUAL)

circuit, the headphones are always on whenever they are plugged in. For this reason, the 510-ohm resistors must be adjusted so that the headphone volume is the same as the loudspeaker volume to prevent the headphones from being over-driven when the loudspeakers are driven at high volume. These resistors also keep the headphones from loading down the loudspeakers when the latter are turned on.

This circuit is also independent of the loudspeaker impedance. Although the drawing shows 8-ohm loudspeakers hooked up, any impedance speaker can be accommodated by changing the tap to which the speaker is connected. The whole circuit fits easily inside a Stereo 70.—James A. Rome **R-E**



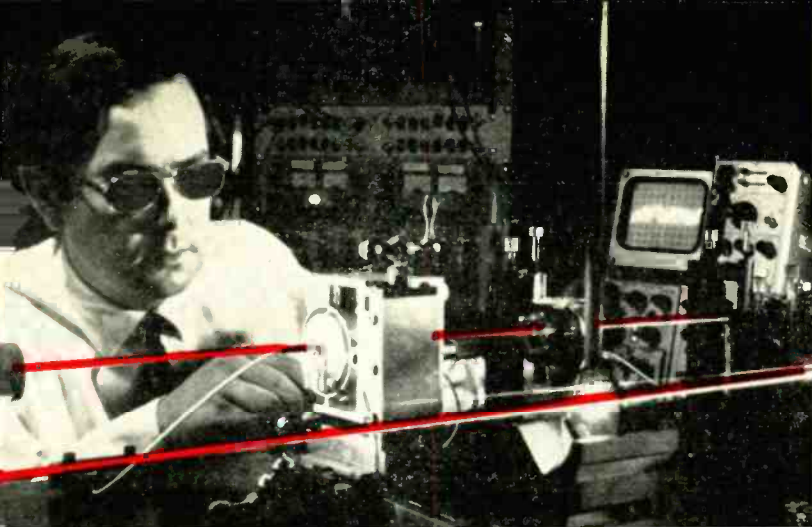

Bell Labs Photo

by U.S. BUREAU OF RADIOLOGICAL HEALTH

This is the second part of a continuing series on lasers. It will cover every aspect of lasers from basic theory of operation to actual experiments that can be performed with low-power lasers.

### Optical cavities

Once the lasing medium has been pumped and a population inversion obtained, lasing action may begin. If, however, no control were placed over the direction of beam propagation, photon beams would be produced in all directions. This is called superradiant lasing.

The direction of beam propagation can be controlled by placing the lasing medium in an optical cavity formed by two reflectors facing each other along a central axis (Fig. 6).

Photon beams which are produced along the cavity axis are reflected 180° at each reflection and travel once more through the lasing medium causing more stimulated emission. Thus, the beam grows in magnitude with each traverse of the lasing medium.

Since the reflectors are not 100% reflective some photons are lost by transmission through the mirrors with each passage. If the pumping is continuous, a state of equilibrium is soon reached between the number of photons produced by atoms raised to the excited state and the number of photons emitted and lost. This results in a continuous laser output and is usually used only with low power-input levels. Higher power inputs usually are achieved in the form of a pulse, and the output is also in pulse form. One of the mirrors in the system is usually made more transparent than the other and the output, pulsed or continuous, is obtained through this reflector.

Q-switching (or Q-spoiling) is used to produce an exceptionally high-power output pulse. The term "Q" as applied to lasers is derived from the more familiar Q of electrical circuits. Lasers are resonant cavities and in a similar way, many electrical devices are resonant. The Q is a numerical index of the ability of the resonant cavity to store energy at the output frequency. The higher the Q, the more effective the power concentration at the resonant frequency. Q-switching in lasers refers to the method of laser operation in which the power of the laser is concentrated into a short burst of coherent radiation. A Q-switch is a device which interrupts the optical cavity for a short period of time during pumping. A schematic of a Q-switched solid state laser is shown in Fig. 7.

Lasing action normally begins as soon as a population inversion is achieved and continues as long as pumping action maintains the inversion. The Q-switch interrupts the optical cavity and reduces the losses due to lasing until pumping can achieve a greater population inversion, say 70 to 80%, the Q switch then suddenly restores the cavity

# THE LASER

**THEORY AND EXPERIMENTS.** This time we see how the laser works and some of the ways it is being used in industry today.

and the resulting pulse is much shorter and more powerful than would normally be achieved.

One example of a Q switch is the Pockel's cell, made of a crystal of ammonium or potassium dihydrogen phosphate (ADP or KDP) sandwiched between two crossed polarizers. In its de-energized state the crystal does not affect polarized light. When an electric field is applied across the crystal, however, the plane of polarization of the incident light is rotated by 90°, allowing it to pass the second crossed polarizer. This completes the optical cavity and results in a "giant pulse."

Reflectors may consist of plane mirrors, curved mirrors, or prisms, as shown in Figs. 6 and 7. The mirror

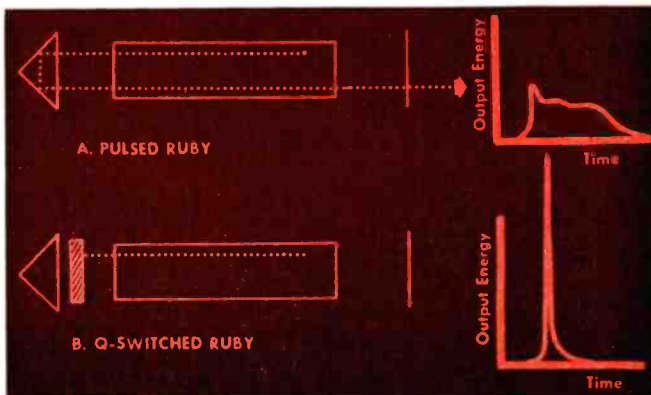
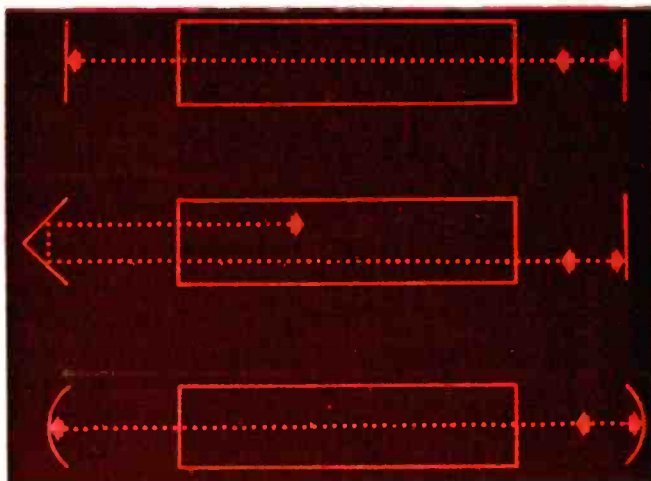

**FIG. 6—(top) OPTICAL CAVITIES** as they are used and how they work. They can be plane mirrors, curved, or prisms. **FIG. 7—(above) Q SWITCH** and pulse output diagram. Note the sharper pulse delivered by the Q-switch approach.

coating may be silver, if laser output power is low, but higher powers may require dichroic material. A dichroic material is a crystalline substance in which two preferred states of polarization of light may be propagated with different velocities and, more important, with different absorption. By appropriate choice of material and thickness, the light impinging upon the dichroic coating may be either totally absorbed or totally reflected. The first ruby lasers were constructed with the crystal ends polished optically flat and silvered. Semiconductor lasers use a similar technique. Gas lasers may use mirrors as seals for the ends of the gas tube or may utilize exterior mirrors. In the latter case, the tubes use end windows of glass or quartz set at Brewster's angle and the output is polarized light.

### The ruby laser

The first laser successfully operated was a ruby laser. It was constructed and operated by Dr. T. H. Maiman in 1960. Ruby is a crystal form of aluminum oxide with about 0.05%, by weight, chromium as an impurity. The chromium gives the ruby its red color and is responsible for the lasing. Chromium has the 3-level energy system, shown in Fig. 8.

In a ruby laser, the electrons of chromium atoms are pumped to an excited energy level by a xenon flashlamp placed beside or around the ruby rod. The chromium electrons absorb photons in a band centered around 545.1 nm and are raised from their ground level to excited level E2.

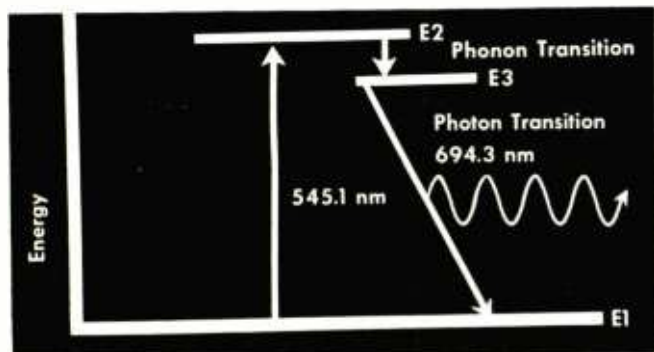

FIG. 8—ENERGY LEVELS OF CHROMIUM. Note that this is a 3-level energy system. The chromium is an impurity in the ruby.

From here they drop almost immediately to level E3 by means of a phonon (radiationless) transition. The small amount of energy lost here is through heat and vibration. The electrons will reside in level E3 for a considerable length of time—much less than a second—but for an electron that is a relatively long time. Thus, since the flashlamp operates in a period of microseconds, a population inversion can be obtained.

The excited atoms begin to de-excite spontaneously, dropping from level E3 to E1, and since a population inversion is in effect, stimulated emission may begin. In any lasing medium, stimulated emission may occur in all directions and no particular direction of propagation is favored. As stated earlier, to control the emission direction and increase the amount of energy within the pulse, the lasing medium is placed in an optical cavity. Photons not emitted along the axis of the cavity pass out of the system and are lost. If, however, a photon cascade is aligned with the cavity axis, it encounters one of the mirrors and is reflected back upon itself, passing once more through the lasing medium and triggering more excited atoms to undergo stimulated emissions. The pulse thus grows in size and on each encounter with the less reflective mirror, part of it emerges from the laser as high intensity coherent light.

The pulse from a typical ruby laser lasts only a few

microseconds, since the pumping is not continuous. The flashlamp is run by a charge stored in capacitor banks, and once the lamp has flashed, the capacitors must be recharged. Pumping occurs over a few hundred microseconds and continues as long as the flashlamp is discharging.

### The He-Ne laser

The most common laser used today in both industry and education is the He-Ne laser. It was first operated in 1961 by Ali Javan and has proved to be the forerunner of a whole family of gas lasers. Since gas lasers are all quite similar in construction and behavior, we shall discuss the He-Ne as representative of the group.

The lasing medium in the He-Ne laser is a mixture of about 90% helium and 10% neon, with neon providing the lasing action. An energy level diagram for neon is shown in Fig. 9.

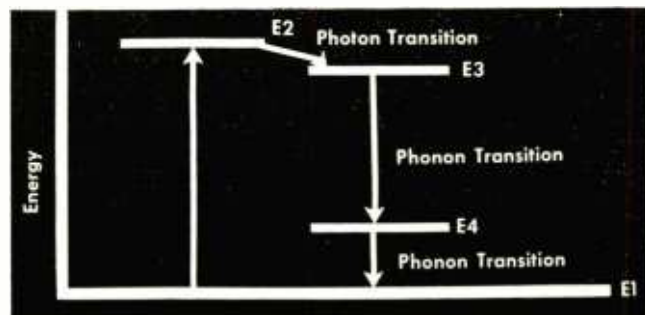

FIG. 9—ENERGY LEVELS OF NEON. The gas laser has a 4-level energy system. It uses 90% helium and 10% neon.

The 4-level system of a gas laser differs from the 3-level system of chromium in that the emission of a photon does not return the atom to a ground level. Transitions from level E3 to E4 and E4 to E1 are accomplished through a phonon transition in which energy is transferred mainly through heat.

Pumping neon to an excited state is not done directly by the energy source. Instead, indirect pumping is provided by exciting atoms of helium which then transfer energy to the new atoms by way of electron collision. These two gases are used because they have electron excitation levels which are almost identical, thus facilitating the necessary energy transfer. Additionally, in the mixture of gases used, one does not need to affect a population inversion in helium to obtain a population inversion in neon. A more complete energy level scheme for He-Ne is in Fig. 10.

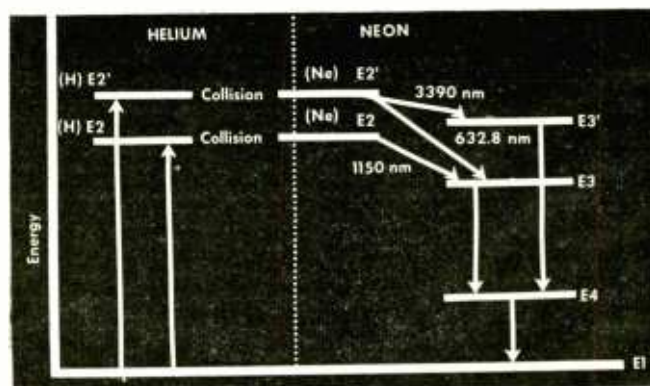

FIG. 10—DETAILED ENERGY LEVEL diagram of a gas laser. Here a mixture of helium and neon is used.

The He-Ne gas mixture is in a sealed tube. Exciting the helium is accomplished by a discharge of electricity through the tube, similar to a neon sign. The mirrors can be enclosed in the tube or may form the end caps of the



tube containing the He-Ne mixture. This is a solid geometrical configuration and results in a stable light output.

Since the alignment of the mirrors is a delicate procedure, one common method is to mount the mirrors separate from the laser tube. When this is done, the ends of the laser tube are made of pyrex or quartz set at Brewster's angle to the axis of the laser, and the output is polarized light.

#### Other lasers

Other lasers operate in similar but more complicated ways. Changes in molecular energy levels may be used rather than changes in electron energy levels, but output is still obtained through the stimulated emission of radiation.

### LASER APPLICATIONS

Soon after the invention of the laser, the device was described as "a solution looking for a problem". Since that time the laser is providing eagerly-sought solutions to a long list of problems in engineering and biology. These solutions and their applications hold great promise for future work.

#### Engineering applications

**Communications:** The higher the frequency of a carrier signal, the greater the amount of information that can be impressed upon it. One optical carrier of He-Ne laser frequency ( $\approx 5 \times 10^{14}$  Hz) could theoretically carry 10,000,000 simultaneous phone calls or 8000 simultaneous television programs. This capability makes the laser very attractive to the communications industry.

Many problems must be solved, however, before practical communications applications are possible. Carrier modulation has been done, but it is a difficult process. Since the carrier is light, point to point transmission can be stopped by such simple things as fog, rain, dust, or an object passing through the beam. One solution being examined is transmission through pipes with mirrors directing the light around bends.

**Tracking and Ranging Systems:** A number of laser tracking and ranging systems are being used today. They are often referred to as LADAR (*LA*ser *D*etection *A*nd *R*anging), just as *RA*dio *D*etection *A*nd *R*anging is referred to as *RA*DAR. Ranging systems record the time it takes a signal to travel to the target and return and translates this time to distance. The minimal divergence of the beam is important because it allows the operator to pinpoint the object for which readings are taken. The Army has developed a range-finder that uses this concept.

**Surveying:** The collimated beam of the laser is ideal for a number of surveying applications. One laser, operating continuously, can replace two men and a transit. Giant earth-boring machines are now aligned using the laser. Bulldozers clearing land, graders leveling land, barges or dredges working on dredging harbors or setting piers, pipe layers and ditch diggers are all using the laser as a simple method for alignment.

**Mechanical measurements:** The Michelson interferometer has been the center of renewed interest since the advent of the laser. Formerly, the interferometer could be used only to measure very small changes in length. Now the device is useful for distances up to several hundred feet. Applications include seismology, where a stable source of coherent light can detect very small earth movements; metalworking, where the interferometer controls the operations of a milling machine; flow rate control; and large scale movements such as building sway or bridge movements.

**Welding and cutting:** The high intensity output capability of the laser was first demonstrated by burning holes in razor blades. Presently this capability is being used on

production lines for cutting and welding. Diamonds are used as dies to make wire. Before the laser, drilling holes in the diamonds took days. Today, the lasers has reduced the cutting time to minutes. Cutting and working of other hard materials is also done easily with the laser. Welding wires in transistors and microchip circuits is also done with lasers, and laser beams can be projected through the envelope of a glass tube to weld broken wires inside.

**Holography:** The laser's coherent light has given new impetus to the photographic process of holography. Three-dimensional images are being used for display devices and as a method of spotting defects in automobile tires, as well as in scientific research applications such as particle size measurement. Recently, a crystal cube has been used to record numerous holograms. The small size of the cube and the large number of three-dimensional images stored may herald a new era in information and data storage and retrieval.

#### Biological applications

**Retinal coagulation:** The retina of the eye is loosely attached to the choroid coat. The retina is of neurodermal origin while the choroid is ectodermal. In the embryo, these two join and throughout the life of the individual are held by a thin layer of connective tissue. In an adult, a number of circumstances can cause the retina to separate from the body of the eye. This results in a loss of vision as the light cannot be properly focused upon the detached retina.

For a number of years, retinas were reattached by using a long needle-like probe to weld the retina to the choroid with a scar. This worked well, producing one or more blind spots but allowing the proper focus to be attained once more. About 1950, the xenon photocoagulator was introduced, producing the same effect with a pulse of intense white light which, when focused by the lens on the retina, effected the reattachment by coagulated blood in a fashion similar to a spot weld.

More recently, retinal repair has been done with a laser as the light source. Ruby lasers were used first, then neodymium, and finally argon lasers. The real value of the argon laser over the xenon photocoagulator is the size of the spot weld. An argon laser can produce welds much smaller than the size of a xenon weld, allowing finer "stitching," this being of particular value around the fovea. In addition, neither anesthesia nor hospitalization is required with laser photocoagulation.

**Skin—cosmetic repair:** The laser's destructive effects have been used to treat skin disorders. Since laser light is preferentially absorbed by pigmented tissue, one of the first experiments undertaken was the removal of tattoos. Favorable results were obtained, leading to further work, especially in the cosmetic treatment of angiomas.

An angioma is an excess of blood and lymph vessels in the upper skin layers. The multitude of fine blood vessels produces a discoloration of the skin and appears as a port wine color. The laser is used to occlude the blood vessels and blanch the skin, leading to an eventual healing of the impact area and restoration of normal skin color.

**Skin cancer:** Skin cancers have been treated experimentally. Since there is a difference between normal and cancerous skin cells, a search is under way for a dye or pigment that is completely selective for cancer cells. Partial results have been obtained and cancer cells can now be stained considerably darker than normal cells. The darker cancer cells are then more susceptible to the impact of a laser beam because they absorb more light energy and are more severely damaged than are normal unstained cells.

Next month we will present more laser applications and start looking into laser safety.

(continued next month)

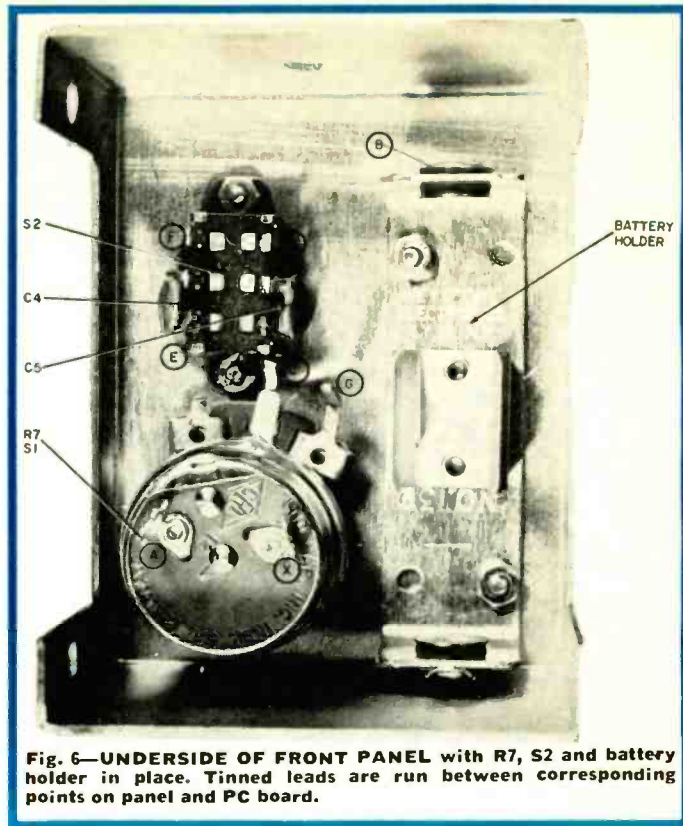
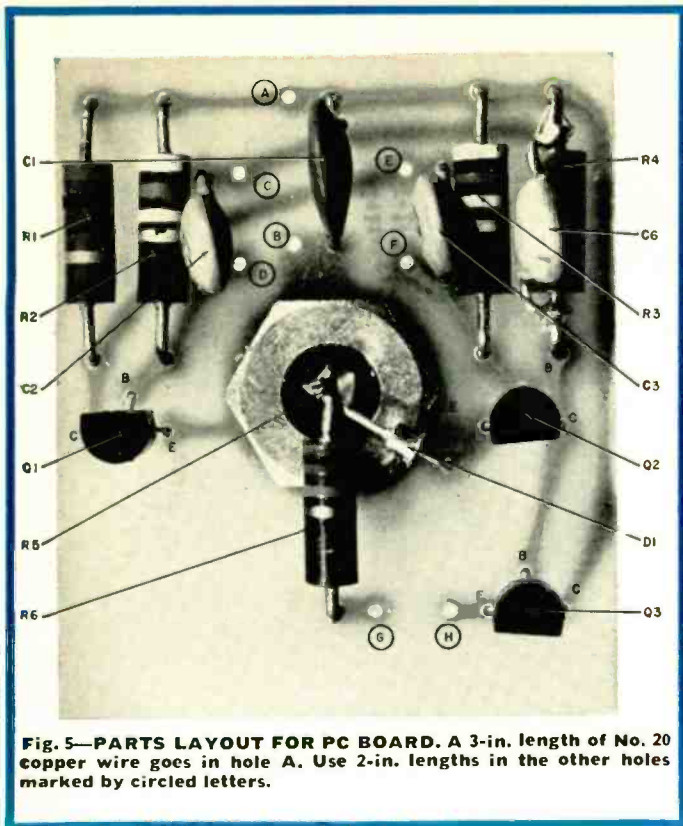

# Build

# A POCKET PIPPER

by TOM ANNES

*Fast risetime pulse generator you can build for about \$12*

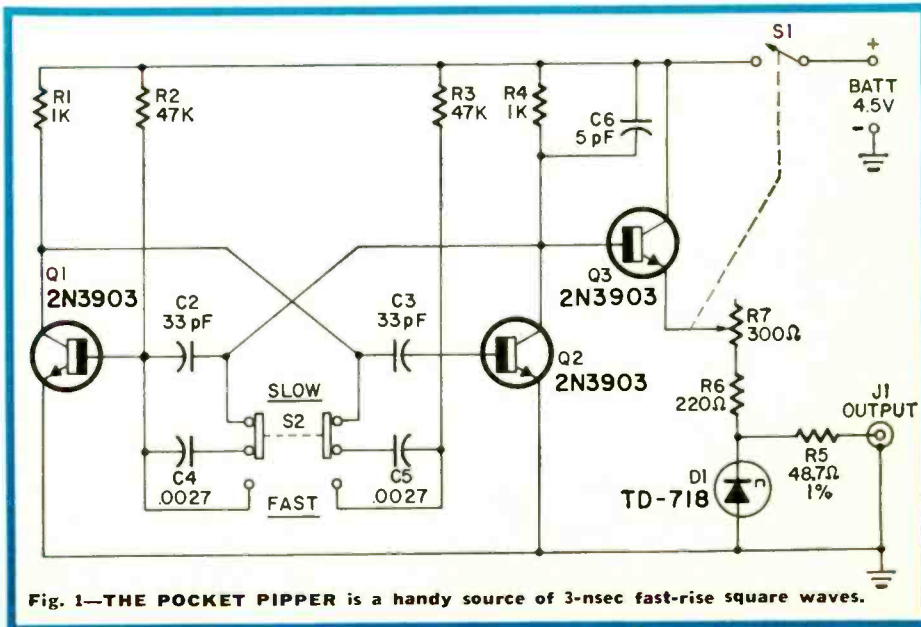
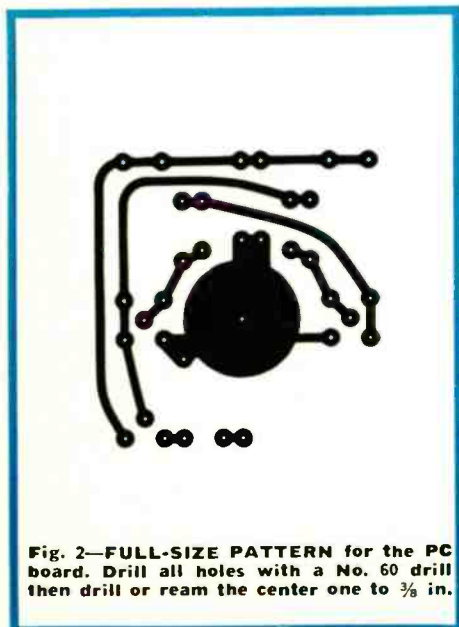





ULTRA-FAST-RISE SQUAREWAVE GENERATORS have many uses in conjunction with an oscilloscope. The first is adjusting peaking coils and the delay line in the scope. This little Pocket Pipper, as shown in Fig. 1, with its risetime of less than 3 nsec, makes an ideal signal source for standardizing the transient response of oscilloscopes with up to 50 MHz bandwidth.

Checking video amplifiers and measuring their risetimes and bandwidths is duck soup with this unit. Fault location in coaxial systems such as TV master antenna systems is another use for this little generator. This is done by using the Pipper as a pulse source and viewing the echos on an oscilloscope—a technique called Time Domain Reflectometry (TDR). This technique is also very practical for locating faults in artificial delay lines. Since the Pipper has a known internal impedance, it can be used to measure the surge impedance of coaxial cable, delay lines and L-C filters.

The unit (Fig. 1) can be built for around \$12.00. The battery is good for about 60 hours of operation. At 90 cents per battery, operating cost is about 1½ cents per hour.

Construction is started by making a PC board per Fig. 2 out of G-10 epoxy glass. Glue the clamping ferrule, fibre washer and R5 together as in Fig. 3. Punch or drill the case as in Fig. 4.

Start assembly by mounting the panel bearing on the PC board. Next, temporarily assemble the coax connector and R5 to the panel bearing. Mount and solder all parts to the board as per Fig. 5. Also solder into the board one 3" length (A) and seven 2" lengths (B-H) of tinned No. 20 wire. Make sure that all soldering is done with a minimum of solder and that all component leads are cut very close to the board. This is very important because clearance between the case and the PC board is only the

thickness of the panel bearing mounting nut.

After the PC board is fully wired, remove the coax connector. Mount the PC board by using a second ⅜" × 32 nut on the panel bushing on the outside of the case, then reinstall the coax connector. Next, mount C4 and C5 on the speed change switch and mount it in the case using No. 2 screws, nuts and lock washers. Next, mount the battery holder with ¾" long No. 2 screws, nuts and lock washers. Bias control R7 is mounted by using a nut as a spacer inside of the case and a nut and flat washer outside the case. The knob is then mounted.

Final hookup is done hooking the eight (8) wires from the PC board to the controls and battery holder. Use Figs. 5 and 6 (on the first page of this article) as guides connecting the leads between points marked by circled letters. The lead dress of the leads from R7 should be as shown in Fig. 7. One extra lead (X-X) has to be installed from the plus side of the battery holder to switch S1 on R7. Install the battery and check the Pipper for proper operation.

Hook the Pipper directly to an oscilloscope with the Pipper speed switch on FAST. Turn it on and slowly advance the bias control. At first the scope pattern should look like Fig. 8-C. As the bias control is advanced, this amplitude should increase to about 65 mV before the tunnel diode switches to the high amplitude state as shown in Fig. 8-B. The fast positive transition is the portion that has an amplitude of about 400 mV. This is the proper bias. A further increase in bias will only cause a rounding of the

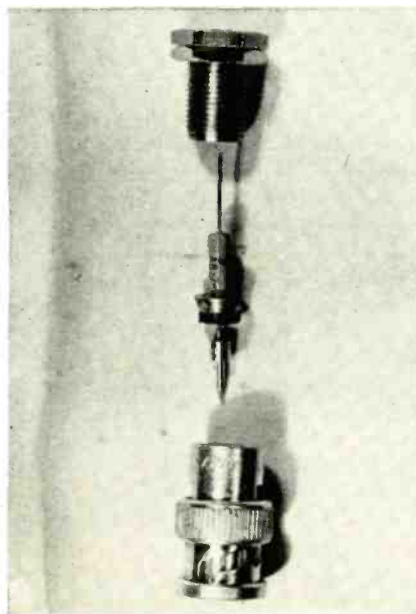

Fig. 3—THIS RESISTOR (R5) sets the internal impedance. Note how it is glued to the clamping ferrule and the fiber washer.

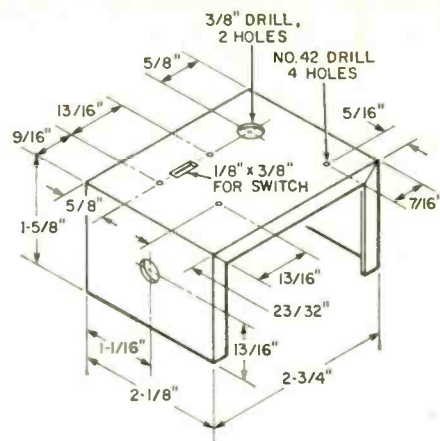

Fig. 4—THE MINIATURE CASE is drilled or punched to the dimensions shown.

leading edge as shown in Fig. 8-A. The frequency should be about 400 kHz.

Repeat this check with the speed changed to SLOW. The frequency of the square wave should be about 4 kHz. The optimum bias control setting should be practically the same for both speeds.

Next step is to repeat these tests with the output terminated in 50 ohms. The results should be about the same as earlier except for two things. First, the bias control should be more advanced for optimum, and second, the output amplitude should be half of what it was without a load.

The Pipper is designed to work into a 50-ohm load for optimum risetime. The Pipper may be used without a load to double the available output voltage. This will increase the risetime somewhat and increase the falltime to about 20 nsec from the normal 5 nsec. The bias control has enough range to permit operation into a short circuit. This type of operation is also safe for the Pipper.

The output voltage is best adjusted by using fixed attenuators or pads. However, it is practical to connect the Pipper across a 50-ohm or 100-ohm carbon potentiometer (don't use wire wound) and take the variable level out between the wiper arm and ground.

#### Parts substitution

The frequency determining capacitors C2 through C5 may be changed to suit individual needs.

The BNC connector is a UG88/U. A UG260/U will also work. However, make sure that the threads in the rear of the connector you select are ⅜" × 32, so as to mate with the panel bushing.

The bias control R7 must be a noninductive potentiometer. The one listed in the parts list is the only low-cost unit located that had a switch on

it and was small enough. An earlier model of the Pocket Pippier used a second slide switch as a power switch. This proved unsatisfactory because it always seemed to get turned on by accident with a resultant dead battery.

Capacitor C6 bypasses any high-frequency noise that may pretrigger the tunnel diode. The listed value may

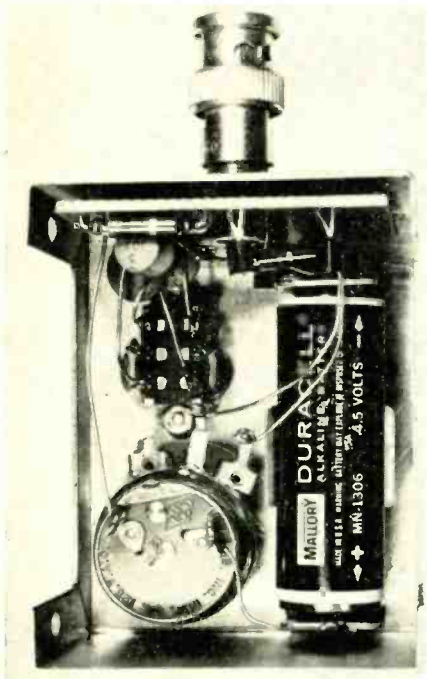

Fig. 7—UNDERSIDE OF POCKET PIPPER with all parts in place. Note how unused lug has been clipped off the potentiometer.

have to be changed if the parts layout is changed.

### How it works

Transistors Q1 and Q2 form a free-running multivibrator. Timing resistors R2 and R3 along with the timing capacitors C2 and C3 give a frequency of operation of about 400 kHz. When the speed change switch puts C4 and C5 in parallel with C2

and C3, this reduces the frequency to about 4 kHz. The square wave in the collector of Q2 drives emitter follower Q3. Q3 drives the 10 mA tunnel diode TD-718 through R6 and R7. Pot R7 is on the front panel and is adjusted to set the peak current through the tunnel diode just high enough to switch to the forward peak voltage.

This switching from the peak to the forward peak voltage is very rapid. The switching time (10-90%) is less than 3 nsec with a TD-718 in use. This switching time can be reduced to about 800 psec by using the more costly TD-253.

The use of a TD-253 tunnel diode will cause some ringing on the top portion of the square wave. The frequency of this ringing is about 3 GHz. This is too high to be seen on anything but the fastest of sampling oscilloscopes.

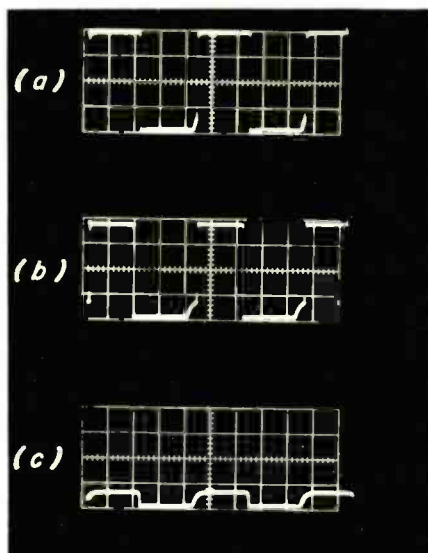

Fig. 8—OUTPUT WAVEFORMS. Rounded positive corners (a) indicate bias control is advanced too far. Pattern b indicates that bias is correct. Bias control is set too low when output drops (c) to about 35 mV when output is terminated in 50 ohms.

The only problem that has shown up is the battery holder contacts. Make sure the battery terminals are clean and the battery is making good contact in the holder. Bend the ends of the battery holder inward if needed.

When the unit is first turned on and the bias control is adjusted for optimum setting, the unit runs for about 30 seconds and requires a readjustment of the bias control. This may be interpreted as a trouble. This is not. It is caused by the battery voltage falling because of the load on it. **R-E**

### PARTS LIST

Resistors 1/2 W, 10%  
 R1, R4—1000 ohms  
 R2, R3—47,000 ohms  
 R5—48.7 ohms metal film, 1%, Electra MF6C or equal  
 R6—220 ohms  
 R7—300 ohms, linear taper pot with spst switch Centralab, F1-300, C1 Taper, with SRS-010 shaft and KR-1 switch

### Capacitors

C1—.05 μF, 20V  
 C2, C3—33 pF  
 C4, C5—.0027 μF  
 C6—5 pF  
 S1—see R7  
 S2—Slide switch, dpdt Continental-Wirt No. G126

Q1, Q2, Q3—2N3903  
 D1—TD-718, tunnel diode (G-E)  
 J1—UG-88/U BNC Connector

### Hardware

Panel bearing, Johnson 115-255  
 Case, 2 3/4" x 2 1/8" x 1 1/2" Bud CU-2100A or equal  
 Knob, Raytheon 70-3-2  
 Battery holder, Keystone No. 139 or equal  
 Battery, Burgess AL-133 or Eveready 523 or Mallory MN-1306  
 PC board  
 2 ea. 3/8" .32 nut  
 1 ea. 3/8" flat washer  
 4 ea. 3/16" x 2-56 screw  
 4 ea. No. 2 washers  
 4 ea. No. 2 nuts  
 1 ea. No. 6 fibre washer

### NOTE:

- The following parts are available from:  
 Tools For Electronics  
 PO Box 2232  
 Denver, Colorado 80201
- (1) Printed Circuit Board etched and drilled. —\$1.50 postpaid
  - (2) R5 glued into the clamping ferrule, with BNC Connector and panel bearing. —\$2.25 postpaid
  - (3) A full set of parts with a punched base, PC board, and R5 glued into ferrule, less battery. —\$11.95 postpaid

### RESISTOR POLYGONS

Resistor substitution boxes are usually in a decade arrangement. However, a more economical, space-saving substitutor can be constructed by connecting resistors in the form of a polygon. A very simple resistor polygon is a triangle. This configuration is not too efficient because there are only three different resistances. More useful configurations are the hexagon and octagon shown. It can readily be seen that the total number of resistances possible is equal to the sum of the number of sides of the polygon and its diagonals. Thus the total number of resistances is  $\frac{N^2 - N}{2}$

where N is the number of sides of the polygon or the number of resistors used. With only 30 resistors it is pos-

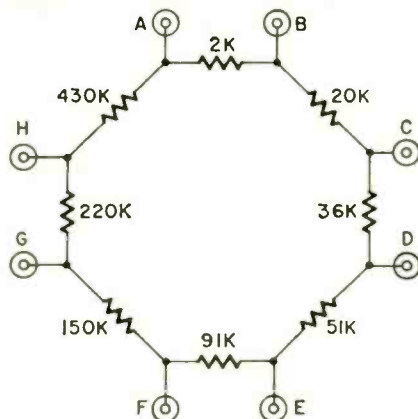

RESISTOR OCTAGON delivers 28 different resistances for substitution, yet requires only eight resistors. Expand this arrangement to 30 resistors, and you can get 435 different resistances.

### RESISTANCE IN K CORRECT TO THE NEAREST HUNDREDTH

	A	B	C	D	E	F	G	H
A	—	2.00	21.52	54.66	97.12	160.0	227.5	245.1
B	2.00	—	19.6	52.86	95.55	159.8	226.9	245.4
C	21.52	19.6	—	34.7	80.43	146.32	220.4	247.7
D	54.66	52.86	34.7	—	48.39	121.84	206.74	249.86
E	97.12	95.55	80.43	48.39	—	82.72	182.9	248.48
F	160.0	159.8	146.32	121.84	82.72	—	127.5	233.1
G	227.5	226.9	220.4	206.74	182.9	127.5	—	245.1
H	245.1	245.4	247.7	249.86	248.48	233.1	245.1	—

sible to have 435 different resistances! Connect a miniature test jack at each vertex of the polygon to accept a pair of test prods. Make a table showing the resistance between any two vertices of the polygon.—J. T. Heydt



# How To Use Operator "j"

"j" is an imaginary number used in many electronic calculations. Here's how you can use it effectively

by JOHN COLLINS

IN ALMOST ANY ARTICLE ABOUT impedance, reactance, resonant circuits or phase angles—in fact, any feature of ac networks—you run into the letter "j". Expressions like " $Z = R + jX_L$ " or " $E = 12 - j16$ " keep turning up. You may learn that j is an *operator* (meaning that it indicates an operation), that the operation is a multiplication by  $-1$  and that the result is an *imaginary number*.

This information may have been interesting, but did little to explain how or why j is used to describe electrical quantities in ac circuits, or why we should bother about imaginary numbers at all. An example may help to clear up the mystery. Suppose we have a 120-volt ac generator connected in series with a resistor and capacitor, as in Fig. 1. A voltmeter shows a drop of 96 volts across the resistor.

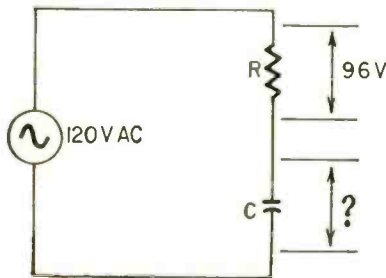

Fig.1

What is the voltage drop across the capacitor?

A beginner might guess 24 volts ( $120 - 96$ ). But the voltmeter shows that the actual drop is 72 volts. The sum of the drops across the two components is much greater than the input voltage!

How is this possible? Look at the *vector diagram*, Fig. 2. Voltage  $E_R$  across the resistor is *in phase* with the current in the circuit (rises and falls in step with it) and is plotted on the horizontal axis. Voltage  $E_C$  across the capacitor does not keep in step, however. Because the capacitor has to be fully charged before the voltage comes up to full, *voltage lags behind current in a capacitive circuit*.

In an ordinary ac circuit, this lag is a quarter of a cycle. The current is at maximum just as the capacitor starts to charge, and voltage is at its lowest. As the capacitor charges, the voltage across it rises and current drops, till at full charge voltage is maximum and current zero. Then, as is the habit of alternating current, the voltage starts to go down, and the capacitor to discharge, till it is discharging at maximum when the source voltage is zero.

This quarter-cycle lag (or *current lead*) is put down mathematically as a  $90^\circ$  lag, and is plotted on the Y axis at

**FIG. 1—SUM IS GREATER THAN THE WHOLE when ac is applied across a series R-C network. FIG. 2—VECTOR DIAGRAM of series R-C voltages.**

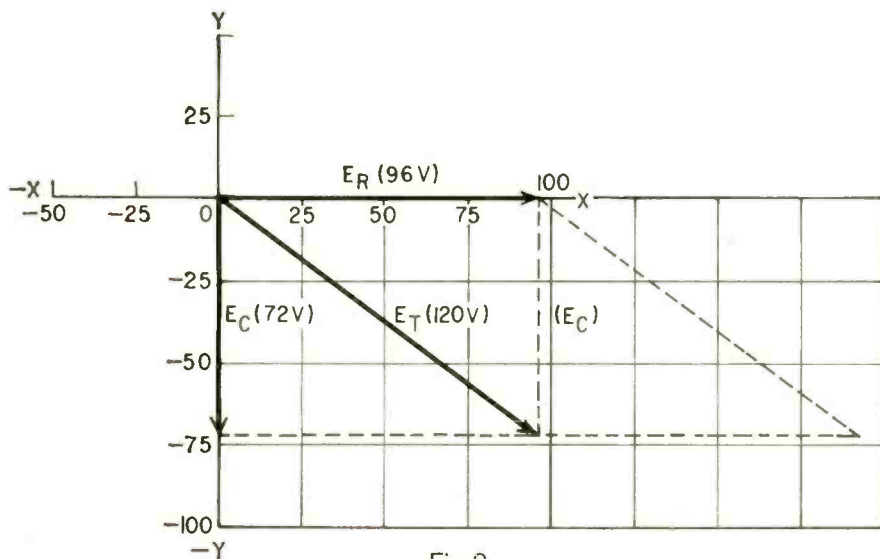

Fig.2

$90^\circ$  from the X axis. Mathematicians have a convention by which capacitive reactance is plotted below the *origin* (the point of intersection of the two axes) and called *negative*, while inductive reactance is called *positive* and plotted above the origin.

The resultant voltage  $E_T$  can be represented by the diagonal of the rectangle in which  $E_R$  and  $E_C$  are adjacent sides.

If the figure is drawn to scale, the diagonal will be approximately equal to 120 when the sides of the rectangle are 96 and 72. The relationship between the voltages would be indicated this way:  $E_T = 96 - j72$ . The j simply indicates that the line (or vector) representing the reactive part of the voltage must be rotated  $90^\circ$  to the vector for the simple resistive part, to show its true relationship.

If we replace the capacitor with an inductor of equal reactance, the voltage drops will be the same, but the voltage across the inductor will *lead* the circuit current by  $90^\circ$ , because the magnetic field building up around the inductor opposes the rising current. It is represented by a line on the Y axis *above* the origin. The equation then becomes  $E_T = 96 + j72$ .

In ac circuits it is almost always necessary to deal with *vectors*, which are quantities having both *magnitude* and *direction*. A typical example of a vector is the diagonal in Fig. 2, which has a magnitude of 120 and a direction at an angle below the X axis. Every vector can be described by a complex number consisting of a *real* term, plotted on the X axis, and an *imaginary* term, plotted on the Y axis:  $96 - j72$ , for example, is a *complex number*.

It may sometimes be necessary to add, subtract, multiply or divide numbers containing j operators. Addition and subtraction are most common, and the easiest. Simply add the *real* and *imaginary* parts separately. Thus  $6 - j8$  added to  $5 - j3$  comes to  $11 - j5$ . Multiplication and division are almost as easy, and the method may be learned without trouble from math books for electronic technicians, such as Nelson Cooke's *Basic Mathematics for Electronics* (McGraw-Hill, \$9.95) or Crowhurst's *Basic Mathematics*, 3 volumes (Rider, \$12.75).

R-E

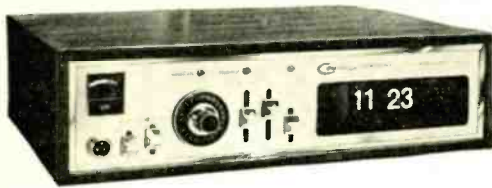

Courier "Citation"



Johnson Messenger 123

# what's a frequency synthesizer?

*Today's method of generating precise transmitter frequencies*

by LARRY ALLEN

YOU'VE PROBABLY HEARD OF IT. CITIZENS-BAND operators talk about it, and hams use it. If you fly a plane much, you've used it—maybe without knowing.

*Synthesis of frequency.* "Putting a frequency together," a dictionary would explain. A design engineer would tell you it's a way of generating a whole batch of frequencies with few crystals. A sensible (and maybe simple) explanation must lie somewhere between these two vague descriptions.

### The old two-by-four trick

Suppose you want to generate an

rf signal. You use an oscillator. If you want the frequency carefully fixed, you include a crystal as the tuning element.

Suppose you want to generate two different rf signals. Two oscillators—and two crystals. For an example, just say one of them is 200 kHz and the other 300.

Now put them together in any kind of mixer. The output, if you remember heterodyne theory, is four signals at four different frequencies. They are: the two original signals, plus one at the difference between the two and another at the sum of the two.

So, two new frequencies have

been put together, or *synthesized*. They are 100 and 500 kHz. If you happen to need them, you have all four from only two crystals. What you've accomplished is simple frequency synthesis.

Of course, the numbers in useful frequency synthesis are seldom that simple. But the process is that simple mathematically, no matter how many decimal places are involved. Synthesis is merely creating new frequencies by signals from oscillators at appropriate frequencies.

### Spanning the CB spectrum

Frequency synthesis is old-hat in communications. But only when it came to CB did it attract attention. For Citizens band, it's largely a novelty. After all, there are only 23 channels in the first place.

And yet, done straight, that would require 46 crystals for transmit and receive. That's why most CB units have only a few channels. But synthesis does the same job with only 12 crystals. Look at how in Fig. 1.

This is the transmitter part of a modern CB unit. Channel 9 makes a good example; it's the road emergency channel. Frequency is 27.065 MHz.

Setting the selector switch to "9" connects crystals X5 and X8 to their oscillators. Frequencies are 8.615 and 10.95 MHz. These two oscillator signals are mixed. Besides the original frequencies, the synthesis converter puts out sum and difference frequencies: 2.335 and 19.565 MHz.

The synthesis converter could be made to favor just one output frequency, but in this model it isn't. All four are fed to the second transmitter converter. There, they mix with a signal from a crystal-controlled 7.5-MHz oscillator.

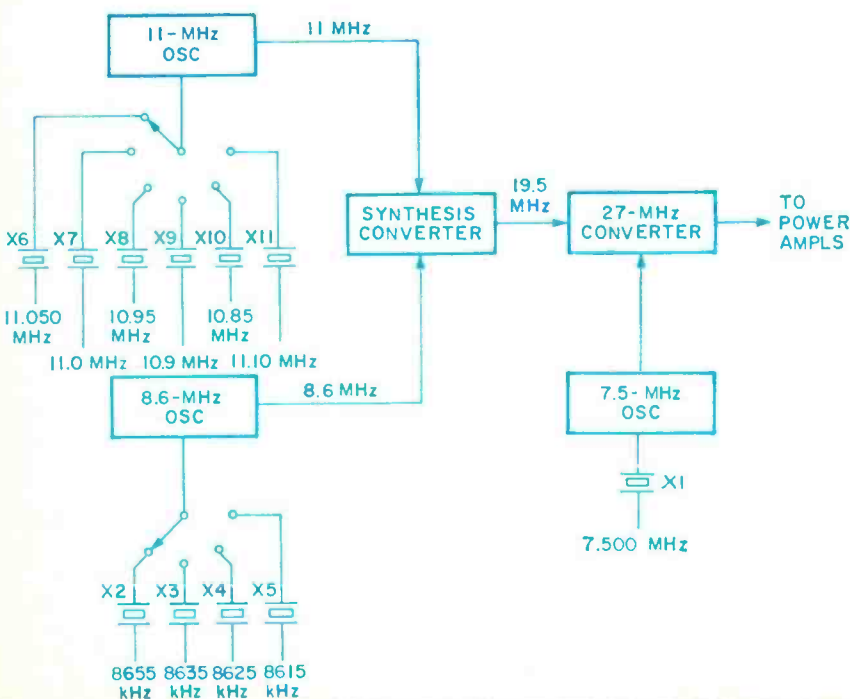

FIG. 1—A HANDFUL OF CRYSTALS in a synthesizer replaces 23 crystals in typical CB rig.



Now you've got eight new frequencies, plus the first four, plus the 7.5-MHz frequency. If you calculate them all, the list is: 1.115, 2.335, 3.450, 5.165, 7.500, 8.615, 9.835, 10.950, 12.065, 16.115, 18.450, 19.565 and 27.065 MHz. The only one you want is that last one, which should look familiar—it's CB channel 9.

The second converter is frequency-selective. A tuned tank picks out signals around 27 MHz and rejects all the others. The 27.065-MHz product of this synthesis is thus sent on alone to the transmitter amplifiers.

Various combinations of the 11-MHz and 8-MHz crystals can synthesize the frequency of any other CB channel. For example, channel 1: The 8.615 and 10.85 crystals produce 19.465; mixed with the 7.5, that synthesizes 26.965 MHz.

Or channel 11: The 8.635 and 10.95 crystals make 19.585; add the 7.5 and you have 27.085 MHz. Or channel 23: The 8.655 and 11.1 crystals add up to 19.755; the 7.5 brings it to 27.255 MHz. Thus, 23 channels of CB transmitter frequencies are synthesized from only 11 crystals.

The same synthesizer can be used for receiving. This is done with the setup in Fig. 2.

Remember from the transmitter calculations that the channel frequency is always 7.5 MHz above the synthesis frequency? Beat the incoming CB signal (after amplification) with that channel's synthesis signal and you get 7.5 MHz. That is taken from the mixer by a 7.5-MHz tank.

From there it's easy to convert the signal to any i.f. In the example, an oscillator with a 7.975-MHz crystal feeds another converter. It beats the 7.5-MHz i.f. down to 475 kHz. A low i.f. is handier to amplify; selectivity can be sharpened easily.

If you've kept count, you know that 46 separate frequency functions are now being handled by 12 crystals. It's done by frequency synthesis.

### The all-country ham

Frequency synthesis can simplify a receiver that must tune signals within a certain spectrum or band. This is what happens in amateur (ham) radio.

A ham receiver covers little bands of frequencies at widely separated spots in the spectrum. For example, the 80-meter band covers from 3.5 to 4.0 MHz; the 40-meter band from 7.0 to 7.3 MHz; the 20-meter band from 14.0 to 14.35; the 15-meter band from 21.0 to 21.45; the 10-meter band from 28.5 to 29.7 MHz. As you can easily imagine, to produce

such diversity of frequencies directly with crystals would demand a fantastic number. A variable-frequency oscillator (vfo) to cover them all would mean having a lot of tuned circuits and switching. You can easily imagine double the trouble in a transceiver.

Frequency synthesis is a solution. Here's an example (Fig. 3). This single-sideband transceiver, in transmit mode, generates first a 9-MHz carrier. Then the single-sideband modulation is added. The 9 MHz has to be heterodyned up or down to the various output frequencies of the transmitter.

For 80 and 20 meters, it is done rather simply. A vfo that tunes 5.0–5.5 MHz heterodynes with the 9-MHz sideband signal in a frequency converter (called *translator*, some-

times). The *difference* tuning range is 3.5–4.0 MHz; the *sum* range is 14.0–14.5 MHz. Band-selector tanks in the output of the converter pick out which band is fed on to the output amplifiers.

For the other bands, a synthesis converter is switched in. Output from the vfo is combined with output from a crystal oscillator. Here's what happens.

Take the 40-meter band. The switch connects the outputs of the 21.5-MHz crystal and vfo to the synthesis converter. Another switch section feeds the output of the synthesis converter to the main frequency converter.

The 21.5 MHz and the 5.0–5.5 MHz synthesize a 16.0–16.5-MHz

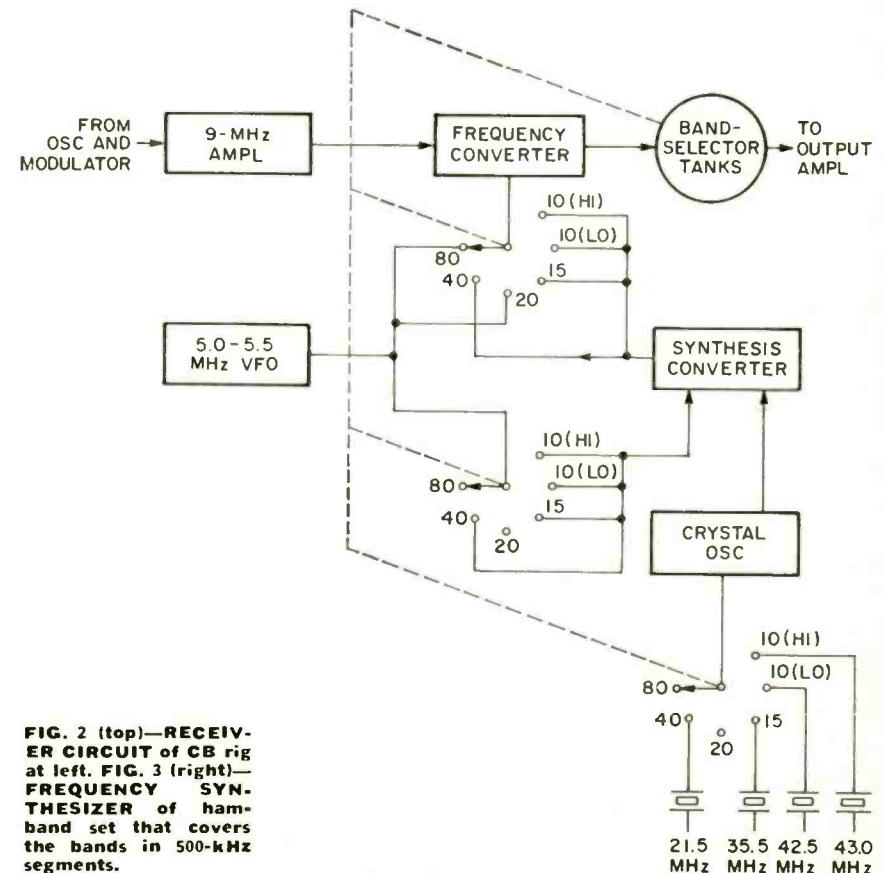
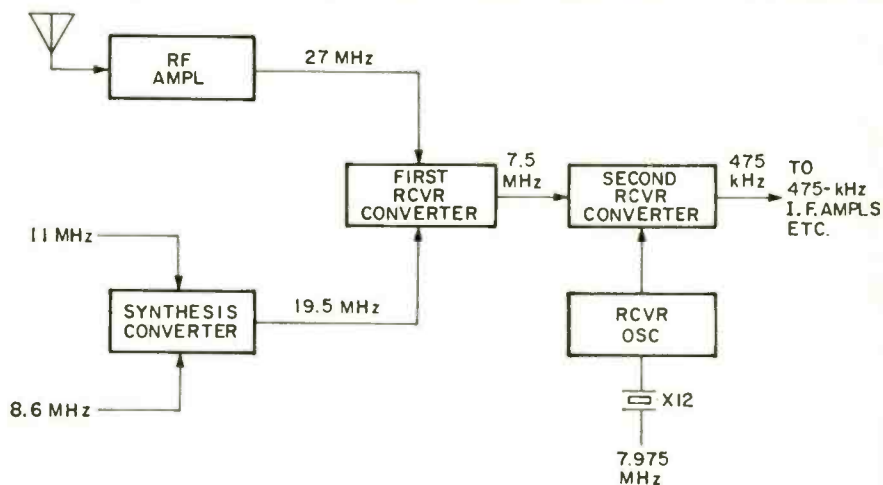

FIG. 2 (top)—RECEIVER CIRCUIT of CB rig at left. FIG. 3 (right)—FREQUENCY SYNTHESIZER of ham-band set that covers the bands in 500-kHz segments.

(difference) range of signals. Beat with the 9-MHz sideband signal, that makes a 7.0–7.5 range of sideband signals. All other differences and sums are blocked by a band-selector tank tuned to center on 7.2 MHz.

At 15 meters, the synthesizer produces 30.0–30.5 MHz. That converts to 21.0–21.5 MHz.

It takes two crystals to cover the 10-meter band. The lower half uses a 42.5-MHz signal in the synthesizer; output is 37.0–37.5 MHz. That converts to 28.0–28.5 MHz. For the upper half, a 43.0-MHz crystal produces

radio in a plane today must transmit *and* receive on every talk channel from 118.0 to 135.95 MHz. Channels are only 0.05 MHz apart. That's 360 channels. A navigation receiver covers 108.0 to 117.9 MHz; with 0.1-MHz channel spacing, that's 100 channels. The clincher is that all these must—by law—have crystal accuracy and stability. Naturally, a synthesis system is the only practical way.

The diagram of Fig. 4 gives you an inkling how one modern aircraft transceiver covers 360 channels. The solid arrows show receiver signal

using only 25 crystals. The digital dials on the three switches read in decimals, and the frequencies received are in steps of 0.05 MHz.

A quick example makes it clearer. Suppose you want to receive 119.50 MHz. You set the MHz dial to 119, the 0.1-MHz dial to 5, and the 0.05-MHz dial to 0. Here's the synthesis.

The MHz switch picks the 147.095-MHz crystal. Its signal mixes with 119.50 to make a 27.595-MHz i.f. The MHz switch has also picked the 27.5-MHz i.f. amplifiers.

The 0.1-MHz switch has picked the 23.095-MHz crystal in the next oscillator. That mixes with 27.595 MHz and forms a 4.5-MHz i.f., which is also amplified.

The 0.05-MHz switch, set for 0, puts a 4.045-MHz crystal into its oscillator. That mixes with 4.5 MHz to create a 455-kHz i.f. That's amplified and sent on to the detector.

Another quick example: receiving 131.65 MHz. The crystals picked by the switches are the 150.095, 22.995 and 4.095 (they're in the charts).

The 150.095-MHz crystal makes an 18.445-MHz i.f. from the 131.65-MHz received signal. The 22.995-MHz crystal beats that down to 4.550 MHz. And the 4.095-MHz signal mixes with that to make 455 kHz.

Transmitter synthesis works in just the opposite direction. The dashed arrows in Fig. 4 show transmitter signal flow. When you set the knobs and dials for a *receive* frequency, another switch deck on the 0.05-MHz dial sets up transmitter crystal synthesis at the same time. The only change is in this low-frequency oscillator crystal.

Example: transmitting 119.50 MHz. The crystal the 0.05-MHz switch selects is 4.500 MHz. The signal is amplified by the same amplifiers used for receiver i.f. In the 0.1-MHz mixer a 23.095 crystal (same as for receive) translates the signal up to 27.595 MHz. And the MHz-step mixer, heterodyning that with the 147.095 vhf crystal forms an output of 119.50 MHz. Tuned tanks keep any other sums or differences from reaching the output amps of the transmitter.

Example: transmitting 131.65 MHz. The low-frequency crystal is 4.550 MHz. The 22.995 crystal heterodynes that—actually producing both 27.545 (sum) and 18.445 (difference). But the MHz switch selects the 18.5-MHz amplifier when it is for 127 MHz or above. So only 18.445 MHz reaches the last transmitter mixer. The 150.095 crystal heterodynes the 18.445 MHz to 131.65 MHz.

R-E

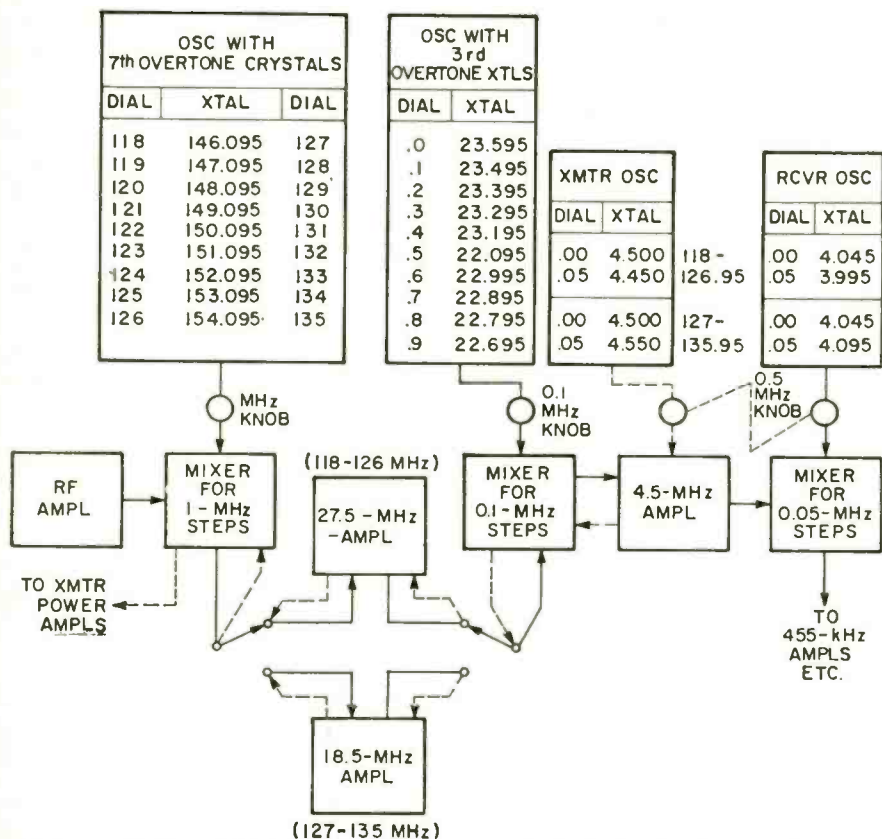

FIG. 4—SYNTHESIS PERMITS DIGITAL FREQUENCY SELECTION in aircraft communications transceiver. Set represented here covers 360 channels with only 23 crystals.

a synthesizer output of 37.5–38.0 MHz, which converts to 28.5–29.0 MHz.

The receiver can use the same converters, crystals and vfo with careful planning. The advantage is obvious. This vfo can be extremely stable and simple, since it has to cover only a narrow range of frequencies. And they can be spread out over a wide dial, making accuracy high. Crystal bandswitching improves accuracy even more.

#### Fly along with decimal synthesis

Where frequency synthesis really shines is in fixed-frequency commercial communications. Aircraft nav-com receivers and transmitters are the best example.

A complete pilot-communications

paths. Nine crystals, oscillating 1 MHz apart at vhf (on their seventh overtone), create i.f.'s around 27.5 MHz or 18.5 MHz, depending on the frequency of the received signal. A digital dial on the switch shaft shows which MHz frequency has been selected. One deck of the MHz-step switch picks the right i.f.

The 27.5 or 18.5 i.f. goes to a mixer for 0.1-MHz steps. Ten third-overtone crystals give a selection of frequencies to beat with whatever i.f. comes to the mixer. The result is around 4.5 MHz.

Finally, one of three low-frequency crystals puts a signal into a mixer for 0.05-MHz steps, beating the signal down to a 455-kHz i.f. Three stages of synthesis thus provide crystal control of all 360 receiving channels,



1

3,373,315  
**FLASHER CIRCUIT FOR ELECTROLUMINESCENT CELLS**  
Robert Colman, 421 E. 80th St., New York, N.Y. 10021  
Filed Oct. 23, 1965, Ser. No. 503,835  
5 Claims. (Cl. 315-240)

## ABSTRACT OF THE DISCLOSURE

A high efficiency power supply which converts a DC 10 voltage to an AC voltage for driving light sources and other loads.

This invention relates generally to a flasher circuit for 15 electroluminescent cells and, more particularly, to a lightweight, low-powered, battery-operable and portable flashing electroluminescent flasher and

2

sistor Circuits"—Sylvania Electric Products Incorporated—copyright 1958, pages 16 and 17—first edition. Circuits of this type have been quite useful as flasher circuits, both with the use of incandescent bulbs as described in the above publication or with electroluminescent cells. It is well known in the art that the lamp of FIGURE 1 can be replaced with a transformer to provide the higher voltage required by electroluminescent cells. The use of such transformers is clearly shown in the patent to Brainerd, Patent No. 3,026,440. Of course, this substitution is well known in the art and further discussion of same is not required.

The flasher circuit of FIGURE 1 includes a timing circuit to provide the proper flasher frequency connected in the feed-back circuit to the base of one transistor. While this circuit provides good flashing results, circuits of this type are expensive and require high power for maximum brightness and have relatively high duty cycles. It has therefore been found that a circuit as represented in FIGURE 1 is not highly desirable when battery operation are required.

# PATENT TALK

by **ARTHUR S. COOKFAIR**

*"Hey Jim, how do I get a patent?"  
"Well Fred, that's what this article is all about."*

It was just two minutes before game time when Jim settled down in front of the TV. The sound of the door chimes brought a warning that his plans were about to be interrupted. The caller was his next door neighbor.

"Hi Fred. Come in, you're just in time for the game."

"No thanks. I haven't got time. I just want to get some information. You know I fool around with radio and I was working with my rig the other day when I got a great idea for a new type of antenna. So I figured that since you're a patent attorney, maybe you could tell me . . ."

After a typical week of working out arguments to convince patent examiners that this or that client's invention was the greatest thing since DeForest added a grid to the vacuum diode, Jim was in no mood to hear about another "great idea"—and the game had just started. He countered quickly, "Why don't we go in and watch the game and you tell me all about your idea afterward?"

Fred wasn't going to be sidetracked that easily.

"Let me tell you about this first, Jim. It will only take a few minutes."

He had that all too familiar look of the inventor with just one thing on his mind—his "great idea." Jim knew there was no sense trying to dissuade him.

"Go ahead," he said weakly.

Fred glowed. "Well, you see I've got this idea for a new type of variable length mercury-column antenna that can be tuned to a hair's breadth and I figured I might as well get a patent on it. I thought that you could tell me where I can get the necessary application forms so that I can get a patent right away."

"Wait a minute, Fred. It's not quite that simple. You don't just fill out an application and get a patent automatically."

By this time they had settled down on the front steps

and Jim could feel his chances of seeing that game getting more and more remote.

"Fill me in, Jim. What's the procedure?"

"First of all," Jim said, "it's best to have a patent search made to find out if your idea is new."

Like many inventors, Fred was so convinced of the novelty of his invention that he couldn't conceive of anyone having thought of it before him.

"I keep up on the latest hardware in this field" he explained, "and I'd know if anyone had an antenna like mine on the market."

"No doubt," said Jim, "But remember that in the last 175 years the U.S. Patent Office has granted more than three million patents. Many of them are good ideas that for one reason or another were never marketed. Sometimes an inventor will get a terrific idea but find that he can't get anyone interested in it. For instance, when Richard Carlson received his patent on xerography, he took it to twenty companies over a period of five years before he got anyone interested in developing the idea. A less persistent inventor might have given up, but the patent would still be in the records. Sometimes an inventor is just too far ahead of his time. Supposing someone patented an antenna like yours back in the early 1900's, when radio was just getting started. The idea might have been ignored and then forgotten because the world of electronics wasn't ready for it."

Fred looked surprised. "Would that stop me from getting a patent on it?"

"I'm afraid so. You see, if the same idea was available to the public or appeared in a printed publication (such as a patent) before your invention of it, you are not entitled to a patent."

"What if I disclose the invention myself?" Fred asked. "I've been thinking of making a few of these antennas and

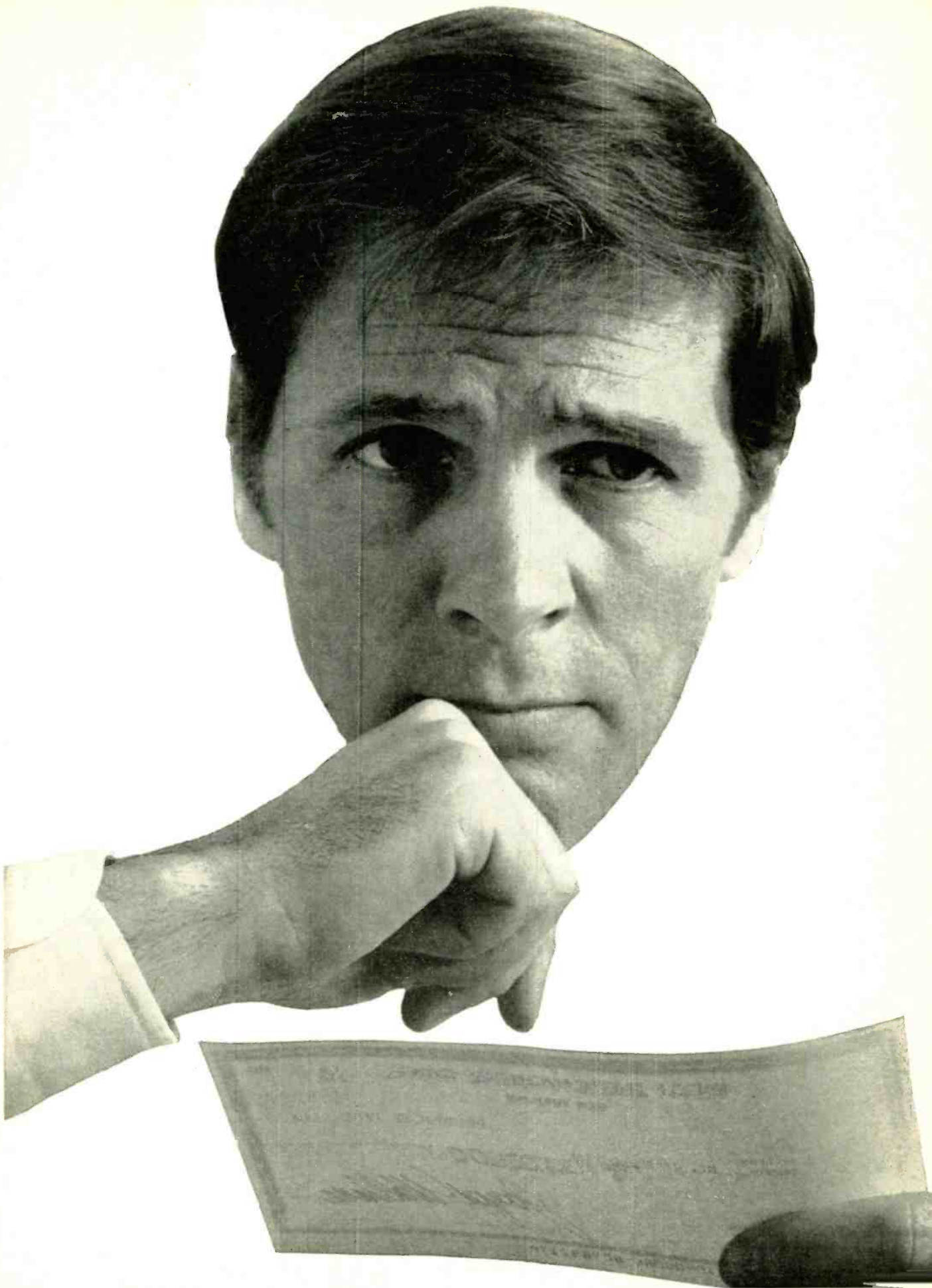



# Your paycheck says a lot about you

It tells you more than how much you make. It tells you how far you've come. And if your paycheck looks very much the same as it did last year, or the year before, it simply means that *you* look very much the same as *you* did last year and the year before.

But times change, and you should be changing with them. Old dull jobs are disappearing. New exciting ones are being created. There are challenging new fields that need electronics technicians...new careers such as computers, automation, television, space electronics where the work is interesting and the earnings are greater.

RCA Institutes has one of the nation's largest and most respected home study schools devoted to electronics. They can get you started even if you've had no previous training or experience. RCA Institutes has developed a faster, easier way for you to gain the skills and the knowledge you need for a fascinating, rewarding electronics career. And you don't have to quit work and go back to school. With RCA Institutes Home Study Plan you can do

both. You set your *own* pace depending on *your* schedule.

Check over these RCA benefits:

- You get Hands-On Training—over 300 experiments and as many as 25 kits with some programs.
- You get RCA's unique "Autotext" method of learning—individual programmed instruction, the *easy, faster, simplified* way to learn!
- You get the widest choice of electronics courses and programs—everything from Electronics Fundamentals right up to Solid State Technology and Communications Electronics.
- You get a selection of low-cost tuition plans!

Sounds great, and it is! For complete information, without obligation, send in the attached postage paid card...or return the coupon below. That will say a lot about you.

Veterans: Train under new GI Bill. Accredited Member National Home Study Council. Licensed by N.Y. State—courses of study and instructional facilities approved by the State Education Department.

## **RCA** Institutes

Home Study Dept. 758-002-1  
320 West 31st Street, New York, N. Y. 10001

Please rush me FREE illustrated catalog.  
I understand that I am under no obligation.

Name \_\_\_\_\_ Age \_\_\_\_\_  
(please print)

Address \_\_\_\_\_

City \_\_\_\_\_ State \_\_\_\_\_ Zip \_\_\_\_\_

Veterans: Check here

If reply card  
is detached—  
send this  
coupon today



selling them. Do I have to apply for a patent first?"

"No, but you must apply for a patent within 12 months after your first public use, disclosure or sale. After that you are barred from getting a patent."

"Can I make some models and mark them 'Patent Pending' since I'll probably file a patent application within a year?"

Jim responded with an emphatic "No." and went on to explain that terms such as "patent pending" and "patent applied for" can only be used to inform the public that a patent application is already on file in the United States Patent Office. Misuse of such terms can result in a heavy fine.

"What if someone else tries to patent the same invention?" Fred asked. "Who gets the patent?"

"When two inventors file separate applications on the same invention," Jim answered, "the Patent Office starts a procedure called an 'interference'. This is an investigation to find out which applicant made the invention first and is legally entitled to a patent. Each party may be called on to prove his date of invention."

"I've heard that I can establish proof of my date of invention by describing it in a letter, sending it to myself by registered mail and then keeping the letter unopened until it's needed for proof. Is that a good idea?"

"It's not a good idea," Jim replied. "It is a common misconception that you can protect your invention that way. But you should keep good written records of your ideas and experiments and have a trustworthy friend follow your progress and read and witness your records. If you should have to prove your date of invention later on, that person can corroborate your statements. It's also a good idea to keep records of purchases and other correspondence relating to your invention."

"Do I have to send a model of the antenna to the Patent Office?"

"It's not likely," Jim replied. "The Commissioner of Patents has the authority to require a model, but it is seldom asked for—except in cases where the Patent Examiner has reason to doubt that an invention will work, for example, where the invention is supposed to be a perpetual motion machine."

"What information do I have to reveal in a patent application?" Fred asked.

"The patent laws require that you provide a written description of your invention in sufficient detail so that a person of reasonable technical skill (electronics technology in this case) could make and use the invention from your description. You're also required to point out what you think is the best way of carrying out your invention."

"Why is it necessary for me to give away so much information about my invention?"

"It isn't exactly a give-away," Jim explained. "It's more like an exchange between you and the public. You see, the idea behind our patent laws is that you, as the inventor, disclose your invention in return for the grant of a patent. The patent gives you a monopoly on your invention for 17 years. In return, you have supplied the necessary information so that after your patent has expired others will be able to practice your invention."

"It sounds as if a patent application might be difficult to write," Fred remarked. "Do I need legal help or can I do it myself?"

"An inventor is legally entitled to handle his own patent application. However very few do," Jim explained. "It takes a good deal of know-how in patent law to do an effective job. A famous judge once said that a patent application is one of the most difficult of all legal documents to prepare. The Patent Office, while permitting an inventor to handle his own case, recommends that he seek the aid of a registered patent agent or patent attorney."

"How long does it take before a patent is granted?"

"The average time is about two and one half years."

"Why so long?"

"The Patent Office receives more than 1600 patent applications *each week*. At present there is a back-log of about 200,000 applications and it takes about a year before an application comes up for action by a Patent Examiner. The examiner must study the application from both a technical and legal standpoint and make a search of the patent and technical literature to determine patentability. Then there is an exchange of opinions and arguments between the Patent Examiner and the applicant (or his attorney or agent) as to the patentability and the exact definition of the invention. The outcome is either a rejection (which may be appealed) or the granting of a patent. The Patent Office issues more than 1000 patents each week (somewhat more than half of the applications filed.) Incidentally, a patent search before filing is a great help in determining the chances of getting a patent.

"A patent application on your invention," Jim went on, "would probably be assigned to a Patent Examiner who is an expert on antennas. You see each examiner is a specialist in some area of technology as well as in patent law."

"Supposing I get a patent on my antenna," Fred questioned, "and someone infringes on my patent. Will the Patent Office help me prosecute the infringer?"

"No," explained Jim. "The Patent Office doesn't have jurisdiction over infringement matters. It would be up to you to sue the infringer in a U.S. Court."

"Would the patent give me protection in other countries?"

"I'm afraid not. Each nation has its own patent laws. A United States patent can protect your invention only in this country. To obtain protection in other countries you would have to get a patent in each country—and that can be pretty expensive."

After a thoughtful pause, Fred responded, "It looks as if there's a lot more to patenting than I had imagined. It would probably be a good idea for me to learn a little more about patents before I go ahead with my invention. Where can I get more information?"

"I have some material in my desk that would be helpful," said Jim, as he disappeared through the door. He returned a minute later and handed Fred some pamphlets.

"These are government pamphlets relating to patents. They are written for inventors like yourself and they offer a great deal of basic information and advice on the subject."

A quick glance at his watch told Jim that the game must be nearly over. With a barely audible sigh of disappointment, he said: "I hope the pamphlets will be of some help."

"Thanks. Maybe this information will help me decide whether to try to patent my antenna."

"By the way Jim, I've been recording the game on my new video tape recorder. How about coming over to my place—I'll fix a couple of cold drinks and we can watch the play-back."

**R-E**  
The following patent pamphlets may be purchased from the Superintendent of Documents, Washington, D.C. or through any field office of the U.S. Department of Commerce:

*General Information Concerning Patents* .....\$30

*Patents and Inventions, An Information Aid For Inventors*

.....\$15

*How To Obtain Information From U.S. Patents* ...\$20

A single copy of the pamphlet: "Answers to Questions Frequently Asked About Patents" can be obtained free of charge by writing to The U.S. Patent Office, Dept. of Information, U.S. Department of Commerce, Washington, D.C. 20230.







**R-E**



Transistor video amplifier  
with video peaking and brightness controls

# Kwik-Fix™ picture and waveform charts

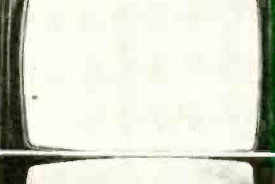
by Forest H. Belt & Associates\*

SCREEN SYMPTOMS AS GUIDES		WHERE TO CHECK FIRST		
SYMPTOM PIC	DESCRIPTION	VOLTAGE	WAVEFORM	PART
	Picture weak and washed out	not much help	WF1 WF2	C1
	Picture dark; not enough brightness	Q1 base Q1 emitter	not much help	R2, R3, R5, R6, R8, R10, R11, C3
	Pic too bright and out of focus; brightness control has little effect	Q1 base Q1 emitter	WF3	R2 R7
	Pic goes out of focus and then dark as brightness is turned up	Q1 collector	WF3 WF5	R4
	Screen black	Q1 collector	inconclusive	R4, R6, R7, R11, R12, C3, L1, Q1
	Contrast too high; brightness control can make picture out-of-focus	not much help	inconclusive	C2 C3
	Picture too bright; focus okay; brightness control has little or no effect	Q1 emitter	inconclusive	R5, R7, R8, R9, R10, C5
	Pix Peak control has no effect	no help	no help	C6 R12

\*an Easy Read™ feature by FOREST H. BELT & Associates © 1971

## NOTES:

Use this guide to help you find which key voltage or waveform to check first.

Study the screen and the action of the three controls.

The most helpful clues for the symptom are found at the key test points listed.

Make voltage or waveform checks as suggested.

Use the Voltage Guide and Waveform Guide to analyze the results of those tests.

For a quick check, test or substitute the parts listed as the most likely cause of the symptom.

### DC VOLTAGES AS GUIDES

change →	to zero	very low	low	slightly low	slightly high	high
<b>Q1 base</b> Normal 7 V *5.5 at max brightness	R7 shorted	R5 open R7 low	R3 open <sup>1</sup> R7 low R8 open R9 open C5 shorted Q1 faulty	R2 open, high R6 open R8 high	R7 open	
<b>Q1 emitter</b> Normal 6.5 V *5 V at max brightness	R7 shorted	R7 low	R3 open <sup>1</sup> R7 low R8 open R9 open C5 shorted Q1 faulty	R2 open, high R5 open R6 open R8 high	L1 open	R7 open R8 low R11 open R12 open
<b>Q1 collector</b> Normal 15 V *18 V at max brightness		Q1 faulty	R4 open, high		R11 high	R2 open, high R3 open R5 open R6 open R7 open R8 low R11 open R12 open L1 open Q1 faulty

<sup>1</sup>Volts low because of Brightness setting

**NOTES:**

Use this guide to help you pinpoint the faulty part. Measure each of the three key voltages with a vtvm. For each, move across to the column that describes whatever change you find in that voltage.

Notice which parts might cause that change. Finally, notice which parts are repeated in the combination of changes you find. Test those parts individually for the fault described.

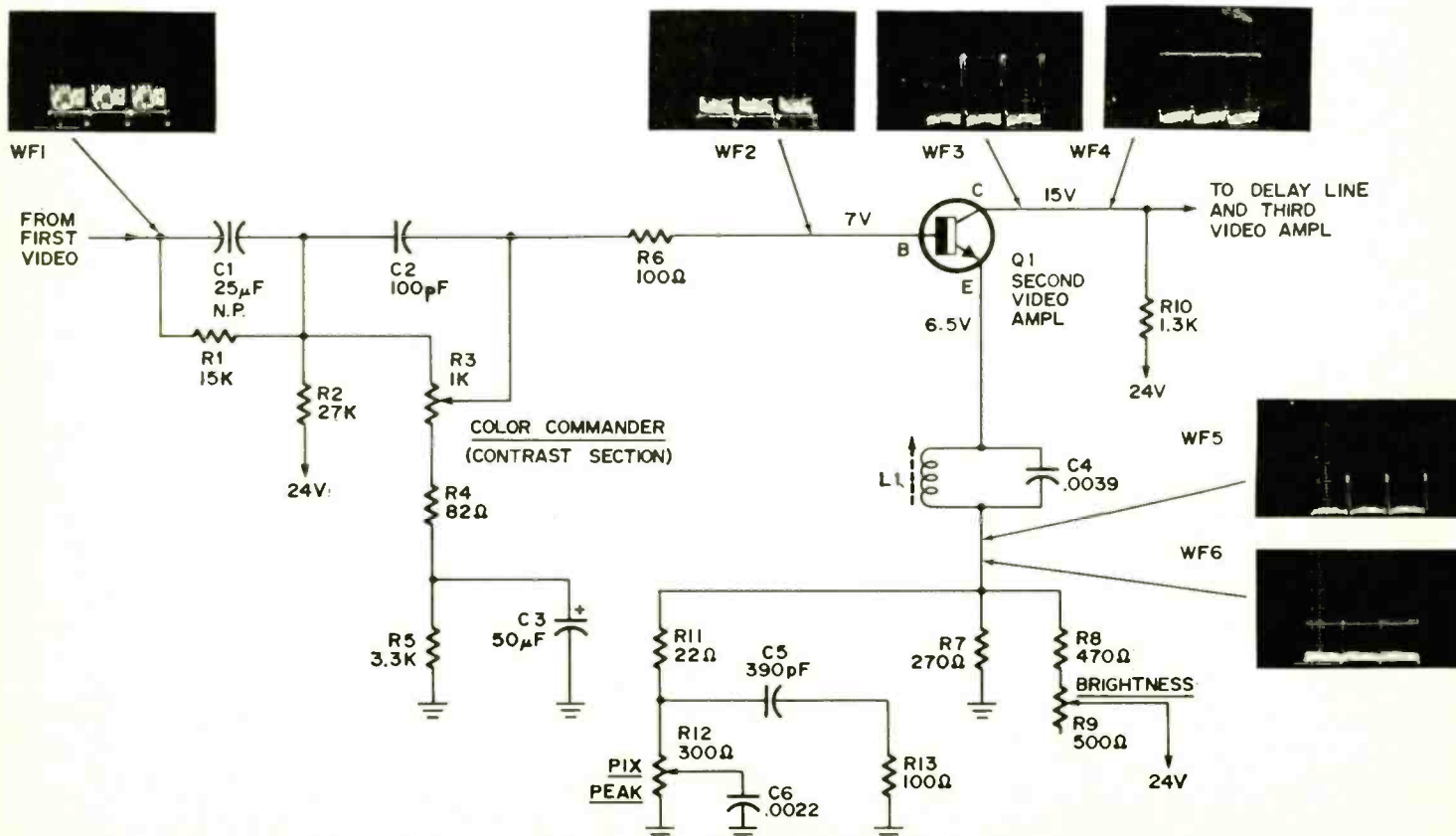



## THE STAGES

This video amplifier is used in transistor and hybrid color TV sets as well as in some monochrome set. The stage used for this example is in a Zenith 4B25C19 color chassis. One distinction is the contrast potentiometer ganged with a chroma-level pot; together they're called **COLOR COMMANDER**. But that part of the dual pot works the same as an ordinary contrast control in any stage like this.

There are connections to this stage which are not shown. They will be covered in the next two *Kwik-Fix*<sup>TM</sup> features. This one involves only the Y-signal (video) portion of this section.

## SIGNAL OPERATION

A 2.5-volt p-p video signal is coupled into the stage from the first video amplifier (an emitter follower) by C1. The input load is R3, the contrast section of the **COLOR COMMANDER** control, and R4. Capacitor C3 decouples them from R5 (which is an input load for signals from certain other stages, see the two following issues). Small-value C2 is for frequency compensation. The position of the R3 slider sets how much video signal is applied through R6 to the base of Q1.

The transistor is wired as a common-emitter amplifier. It gives a healthy boost to the video-signal amplitude, as you can see by comparing WF2 with the video portion of WF3. R10 is the output load for the collector of Q1.

In the emitter circuit, L1 and C4 resonate (L1 is adjustable) to trap out any beat signal that may develop between the chroma and sound carriers when they mix together in the video detector.

A network of resistors and capacitors constitutes a peaking circuit in the emitter circuit of Q1. They are R11, C5, R13, R12 (the **PIX PEAK** control), and C6. Adjusting the slider of R12 lets C6 have more effect or less; turning the slider toward the bottom of the control sharpens video peaks.

## DC DISTRIBUTION

For all practical purposes, the input of this stage is ac-coupled. The output, however, is dc-coupled.

Base voltage for Q1 is developed from the 24-volt dc supply, with R2-R3-R4-R5 forming the divider. Moving the slider of R3 has almost no effect on the voltage measured at the base, because the value of R3 is only a small portion

of the whole divider.

The collector supply comes through R10, from the 24-volt dc line. There's also a dc source not visible in this schematic, through the delay line. That's why an open R10 doesn't remove collector voltage.

The emitter dc circuit has several branches. You can see two paths to ground in this schematic—through R11-R12 and through R7. Voltage for the emitter comes mainly from the 24-volt line, through R9 (the **BRIGHTNESS** control) and R8. R9 can control brightness on the picture-tube screen because of dc coupling from this stage to the third video amp and from that stage to the picture tube.

An unseen stage, the automatic brightness limiter, also affects dc voltage at the emitter of Q1; the interrelationship will be explained in the next *Kwik-Fix*<sup>TM</sup>.

## SIGNAL AND CONTROL EFFECTS

Station signal does affect the amplitudes of video waveforms WF1 and WF2. But the effect on WF3, WF4, WF5, and WF6 appears slight. That's because those waveforms are dominated by blanking pulses. The video portion is only a small bit along the bottom. Station signal has almost no effect on dc voltages.

Control R3 affects the amount of video passed on to Q1. For testing, a setting about two-thirds of full clockwise is standard. It affects amplitude of WF2 directly, but only affects the video portions of WF3 through WF6.

The effect of the peaking control is noticeable only on the screen. You can't see its effect in waveforms nor in dc voltages.

R9 does affect dc voltages. It alters emitter and base voltages about a half-volt, and shifts the collector voltage as much as 3 volts. For testing, again the best setting is about two-thirds up.

## QUICK TROUBLESHOOTING

You have two things to consider in this kind of video stage: how it handles signals, and its dc operation. If the symptom is in the video level—the contrast of the picture—chances are the scope will be the most help to you. If raster brightness is the problem, you'll get to the root quicker with your vtvm.

Also study the action of the three controls. You can pin down many borderline faults by testing the circuit in which a control doesn't work right.

**R-E**  
(Waveforms continue on pages 62 and 63)

## WAVEFORMS AS GUIDES



WF1 Normal 2.5 V p-p

This is the input waveform, coming from the emitter of the first video amplifier stage. Polarity is the same as the signal right out of the video detector, with sync pulses pointing negative. This waveform is displayed at the horizontal rate, because the vertical-rate waveform doesn't show much information of value.

V p-p low

V p-p high

V p-p zero



0.4 V p-p  
C1 open

WAVEFORMS AS GUIDES

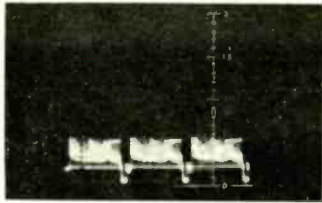

WF2 Normal 0.7 V p-p

Taken at the base of Q1, this waveform is the signal from the slider of R3, the contrast control. The amplitude listed here is about normal to produce a picture with good gray scale, if all the stages from here to the picture tube are working properly. Control R3 is set about two-thirds clockwise. The scope locks this waveform best in the negative sync mode.

V p-p low	V p-p high	V p-p zero R3 open	 0.2 V p-p C1 open	 8 V p-p C3 open	 5 V p-p R6 high
-----------	------------	-----------------------	--------------------------	------------------------	------------------------

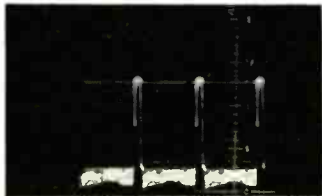

WF3 Normal 13 V p-p

Taken at the collector of Q1, with the scope set to show horizontal pulses. The horizontal blanking pulse dominates the waveform, leaving only a small part—about 3 volts p-p—of the overall amplitude taken up by video. The scope locks this waveform best in the positive sync mode.

V p-p low R2 open R7 open R10 low	V p-p high	V p-p zero R5 low R11 open R12 open C3 leaky L1 open Q1 faulty	 13 V p-p C1 open	 13 V p-p R2 open	 4 V p-p R3 open	 13 V p-p R4 open
			 15 V p-p C3 open	 20 V p-p R6 high	 10 V p-p R6 open	 13 V p-p R7 low



WF4 Normal 13 V p-p

This waveform also is taken at the collector of Q1, but with the scope set for vertical frames. Again, the dominant feature is the blanking pulse—vertical blanking in this case. If you look closely, you can see vertical sync pulses between each frame of video. The scope locks this waveform best on positive sync.

V p-p low R2 open R6 open R7 open R10 low	V p-p high	V p-p zero R6 open R11 open R12 open L1 open Q1 faulty	 13 V p-p C1 open	 13 V p-p C3 open	 20 V p-p R7 low
---	------------	---	-------------------------	-------------------------	------------------------

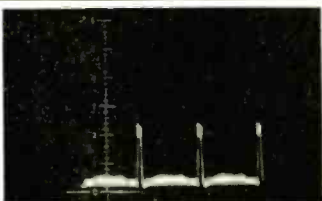







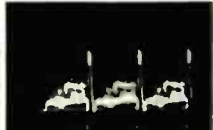

WF5 Normal 2.5 V p-p

Taken in the emitter circuit of Q1, with the scope set to show horizontal pulses. Video is almost not noticeable, being overshadowed by the horizontal blanking pulses. Blanking is positive-going here, the same as in the collector circuit; being applied at the emitter, the blanking signal isn't inverted by the amplifier (the video is inverted, being applied at the base).

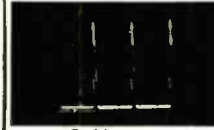
V p-p low R7 low C5 shorted	V p-p high R11 high	V p-p zero R2 low	 2 V p-p C1 open	 4 V p-p R2 open	 4 V p-p R3 open	 1.5 V p-p R4 high
-----------------------------------	------------------------	----------------------	------------------------	------------------------	------------------------	--------------------------



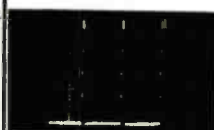





WAVEFORMS AS GUIDES

			 <p>4 V p-p C3 open</p>	 <p>4.2 V p-p C3 leaky R5 low</p>	 <p>6 V p-p R6 open</p>	 <p>4 V p-p L1 open</p>
			 <p>6 V p-p R7 open</p>	 <p>3 V p-p R8 low</p>	 <p>6 V p-p R11 open R12 open</p>	 <p>3.5 V p-p Q1 faulty</p>

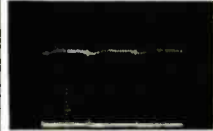

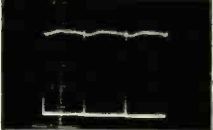
WF6 Normal 5 V p-p

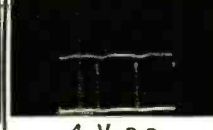
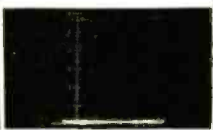
Also taken in the emitter circuit of Q1, but with the scope set for vertical frames. The blanking pulses dominate. You can see the vertical sync, and notice that it's the same polarity as the sync in WF1 and WF2—negative-going. There's no inversion from base to emitter in this amplifier. The display locks best with scope sync positive.

V p-p low R2 low R7 low C5 shorted	V p-p high R2 open	V p-p zero	 <p>5 V p-p C1 open</p>	 <p>4 V p-p R3 open</p>	 <p>5 V p-p R4 high</p>	 <p>7 V p-p C3 open</p>
			 <p>6 V p-p C3 leaky R5 low</p>	 <p>6 V p-p R6 open</p>	 <p>6 V p-p R7 open</p>	 <p>4 V p-p R8 low</p>
			 <p>7 V p-p R11 open R12 open</p>	 <p>6 V p-p L1 open</p>		

NOTES:

Use this guide and the Voltage Guide to help you pin down fault possibilities.

Use the direct probe of the scope. Set scope frequency to show three cycles of the waveform. For WF1, WF2, WF3, and WF5, set scope for about 5 kHz; for WF4

and WF6, use about 20 Hz.

Check the six waveforms at the four key test points.

Note amplitude. If it's low or high, check the parts listed under those columns.

Note waveshape. If there's a change that matches one shown, check the parts indicated.

# Design for STEREO

by MANNIE HOROWITZ\*

## how to design your own solid-state audio amplifier

### Part III: Introducing transistor types and characteristics—facts you'll need when designing your amplifier.

TAKE A SLAB OF P-TYPE SEMICONDUCTOR. Place one n-type slab in intimate contact with the p-type material. The resulting device is the junction diode discussed in the first two articles (December 1970, January 1971). Now add a second n-type slab in close contact with the other side of the p-type material. The new configuration is the npn bipolar transistor.

#### The npn bipolar transistor

The illustration in Fig. 1 is a

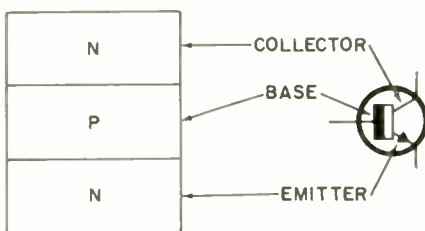

FIG. 1—PHYSICAL AND SCHEMATIC representations of an npn transistor.

physical representation and schematic drawing of the transistor. The three semiconductor slabs are assigned names—emitter, base and collector.

Note that the base and emitter form one diode; the base and collector form a second. In audio applications, the base-emitter junction is forward biased and the base-collector is reverse biased. In the case of the npn transistor, the base is made positive with respect to the emitter and negative with respect to the collector. As was the case when discussing the diode, the

arrow in the schematic of the transistor drawings also indicate the direction of conventional current flow through the device. In the npn transistor shown, it flows from the base (and collector) to the emitter.

The emitter current,  $I_E$ , consists of the sum of two currents—the collector current,  $I_C$ , and the base current  $I_B$ . Stated mathematically,  $I_E = I_C + I_B$ .

One important relationship between the currents is the ratio of steady-state (dc) collector current to the steady-state emitter current. This ratio is assigned the Greek letter *alpha*  $\alpha$ . The direct-current gain ( $\alpha_{dc}$ ) of the transistor is

$$\alpha_{dc} = I_C / I_E \quad \text{Eq. 1}$$

As  $I_C$  is less than  $I_E$ ,  $\alpha_{dc}$  is always less than one. In most transistors, it is so close to this limiting value that it is indistinguishable from 1.

To establish a second relationship between  $\alpha_{dc}$  and the various currents, assume for the moment that the emitter current is 1 ampere. The collector current is  $\alpha_{dc}$  while the current flowing through the base is  $I_B = 1 - \alpha_{dc}$  amperes.

Another important ratio to be remembered is that of the collector direct current to the base direct current. The Greek *beta*  $\beta$ , is the letter representing this ratio. The direct-current gain from the base to the collector is  $\beta_{dc}$ .

$$\beta_{dc} = I_C / I_B \quad \text{Eq. 2}$$

$I_C$  is usually much greater than  $I_B$ .  $\beta_{dc}$  normally ranges from 1 to 1000.

A bit of arithmetic manipulation

can be used to establish the relationship between  $\alpha$  and  $\beta$ .

$$\alpha = \beta / (\beta + 1) \quad \text{Eq. 3}$$

$$\beta = \alpha / (1 - \alpha) \quad \text{Eq. 4}$$

From the foregoing, we see that alpha and beta are simply ratios of output current divided by input current; or measures of current gain. When the transistor is operated with the *base* at ground potential so it is common to both input and output circuits, the arrangement is called a *grounded-base* or *common-base* circuit and current gain is alpha. When the transistor emitter is at ground potential, we have a grounded-or common-emitter circuit and current gain is beta. Dc alpha and beta are often represented by  $h_{FB}$  and  $h_{FE}$ , in transistor manuals and data sheets.

#### A bipolar circuit

If a current  $I_B$  is fed into the base, the collector current should be, from equation 2, about  $\beta_{dc} I_B$ . (The "about" in this statement stems from leakage factors to be discussed in the future.)

Let's hook up the transistor circuit

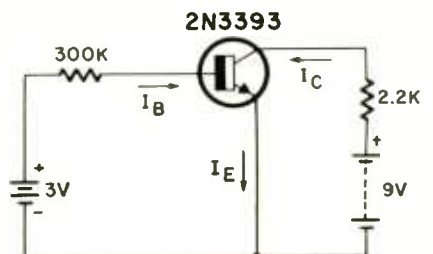

FIG. 2—HOW TRANSISTOR IS BIASED in an experimental circuit arrangement.

\*Chief Project Engineer, EICO Electronic Instrument Co. Inc.



in Fig. 2. The 2N3393 is specified as having a beta range of 100 to 300. We will assume a nominal beta of 200. We will also assume zero dc resistance in the base-emitter diode. Set up the circuit and see if the results you find through measurements are as predicted in the calculations below.

The base current is (3 volts/300,000 ohms) =  $10^{-5}$  amperes. The collector current should be about  $\beta \times 10^{-5} = 200 \times 10^{-5} = 2 \times 10^{-3}$  amperes. If this is true, then the voltage across the 2200-ohm resistor is (2200 ohms) ( $2 \times 10^{-3}$  amperes) = 4.4 volts. This voltage can be checked accurately with an ordinary vom if the resistance of the meter range used is much higher than 2200 ohms. Otherwise, use a tvm or vtvm.

Variations will occur. The beta of the 2N3393 can be anywhere between 100 and 300. Assume that the beta is at one extreme—100. Then  $I_b$  is  $10^{-5} \times 100 = 10^{-3}$  amperes and the voltage across the 2200-ohm resistor is  $2200 \times 10^{-3} = 2.2$  volts. Should beta be at the upper extreme of the range at 300, the collector current is  $10^{-5} \times 300 = 3 \times 10^{-3}$  amperes and the voltage across the collector resistor is  $2200 \times 3 \times 10^{-3} = 6.6$  volts. The voltage across the resistor can vary, at least, from 2.2 volts to 6.6 volts, depending upon the particular 2N3393 transistor used in the circuit. Methods have been devised to reduce the size of this variation.

### Pnp transistors

Only one form of transistor is shown in Fig. 1. Should n-type material be sandwiched between two slabs of p-type material, as shown in Fig. 3,

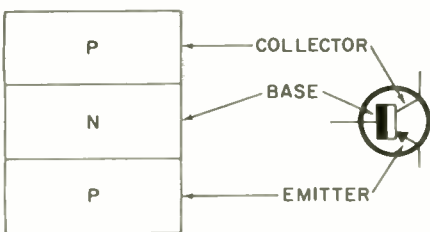

FIG. 3—SCHEMATIC AND PHYSICAL representations of a pnp transistor.

a second form of the bipolar transistor has been formed. This is the pnp transistor.

Everything that has been written here about the npn device applies equally to the pnp transistor. Only the polarities of the power supplies must be reversed. For the base-emitter junction to be forward biased, the base must be negative with respect to the emitter. Following this logic, the base must be positive with respect to the collector if there is to be no conduction through this junction.

Although pnp and npn devices

are made from both germanium and silicon semiconductor materials, silicon transistors are primarily npn and germanium are mostly pnp. As silicon transistors currently dominate the field, the discussion will generally consider npn devices. However, all facts are applicable to pnp transistors as well. Only the polarity of the power supplies must be reversed to accommodate these devices.

### Ac alpha and beta

Dc alpha and beta define the current gain for the transistor at one point of operation. In the example, when  $10^{-5}$  amp flows to the base, a current of  $2 \times 10^{-3}$  amp flows through the collector circuit, assuming  $\beta_{dc} = 200$ .

Now feed current the base with a current of  $5 \times 10^{-6}$  amp. peak-to-peak. Assume this current is riding on top of the  $10^{-5}$  dc amp. The situation is shown in Fig. 4.

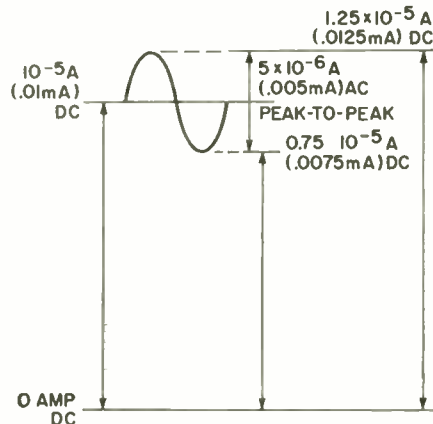

FIG. 4—THE AC INPUT SIGNAL is superimposed on a dc base bias current.

As the peak ac is  $0.25 \times 10^{-5}$  amperes, the current fed to the base at this instant is  $10^{-5} \text{A} + 0.25 \times 10^{-5} \text{A} = 1.25 \times 10^{-5} \text{A}$ . At the crest of the signal, the current fed to the base is  $10^{-5} \text{A} - 0.25 \times 10^{-5} \text{A} = 0.75 \times 10^{-5} \text{A}$ . When  $\beta_{dc}$  equals 200, the collector current at the instant of peak base current is  $200(1.25 \times 10^{-5}) = 2.5 \times 10^{-3} \text{A}$ . At the moment the current fed to the base is at a minimum, the collector current is  $200(0.75 \times 10^{-5}) = 1.5 \times 10^{-3} \text{A}$ . The peak-to-peak output current is  $2.5 \times 10^{-3} - 1.5 \times 10^{-3} = 10^{-3} \text{A}$ . Thus with an ac input to the base of  $5 \times 10^{-6} \text{A}$ , the output at the collector is  $10^{-3} \text{A}$ , and the ac current gain in this example is  $10^{-3}/5 \times 10^{-6} = 200$ .

In this very approximate example, the ac current gain is identical in value to the dc beta. Ac beta or current gain,  $\beta_{ac}$ , is usually very close in value to  $\beta_{dc}$ . And  $\beta_{ac}$  is defined as the ratio of the difference of two dc current levels.

$$\beta_{ac} = \frac{I_{C2} - I_{C1}}{I_{B2} - I_{B1}} = \frac{\Delta I_C}{\Delta I_B} \quad \text{Eq. 5}$$

Similarly,

$$\alpha_{ac} = \frac{I_{C2} - I_{C1}}{I_{E2} - I_{E1}} = \frac{\Delta I_C}{\Delta I_E} \quad \text{Eq. 6}$$

where  $I_{C2}$  is the collector current flowing when  $I_{B2}$  or  $I_{E2}$  is fed to the base or emitter, respectively.  $I_{C1}$  is the collector current flowing when  $I_{B1}$  or  $I_{E1}$  is fed to the base or emitter, respectively. Delta ( $\Delta$ ) is a symbol indicating a change of value, such as  $\Delta I_C$  is a change of collector current,  $\Delta I_B$  is a change in base current, etc.

### Inside the FET

The input impedance of the bipolar transistor is relatively low due to the forward bias requirement of the input base-emitter diode. An important comparative characteristic of the field-effect transistor (FET) is the higher input impedance. Its input circuit is reversed biased.

FET's can be divided into two basic groups. One type is abbreviated JFET for junction field effect transistor and the other is known by the letters IGFET for insulated gate field effect transistor, or MOS and MOST for metal oxide semiconductor field effect transistor. The IGFET is identical to the MOS and MOST. The structure of the JFET differs from that of the IGFET. The former is currently more applicable to audio circuits due to its inherent lower noise characteristic.

The physical representation of the n-channel JFET and its schematic, are shown in Fig. 5. An n-type semi-

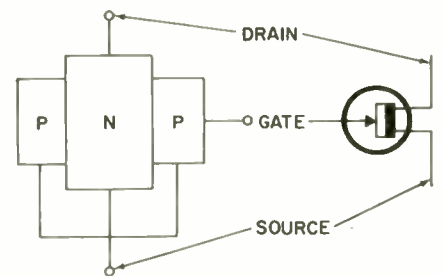

FIG. 5—PHYSICAL AND SCHEMATIC representations of an n-channel JFET.

conductor channel connects two terminals known as the drain and the source. Current flows through this channel. A third terminal, the gate, is connected to the p-slabs. These p-slabs form a junction with the channel. The relative voltage on the gate with respect to the source determines the amount of current flowing through the channel. In the usual bias arrangement, the drain is made positive with respect to the source while the gate is made negative.

The resistance from the source to the drain is merely the resistance of the n-slab. It is usually only several hundred ohms. Current flows through

(continued on page 74)

# MICROWAVE OVENS

a brand new

*Concentrated microwave energy*

*Here's why, and*



**MC-24 OVEN** from International Crystal fits on a countertop, cooks in minutes.

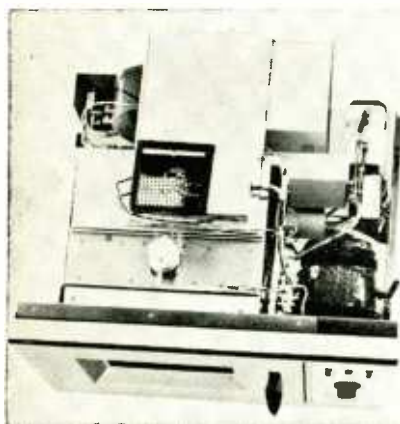

**COVER OFF** reveals the oven cavity, and electronic circuits that make the oven work.

by **LARRY STECKLER**  
EDITOR

MICROWAVE OVENS ARE THE LATEST ITEM IN HOME ELECTRONICS. They are becoming more and more popular, so don't be too surprised to find yourself running into them from time to time. Fortunately, they are also a relatively uncomplicated device. In this article you will discover how they work, some cautions in working with and on them, and some tips on how to keep them working.

## How microwaves cook

Foods are heated in the microwave oven by the absorption of microwave power. All food is constructed of many millions of molecules per cubic inch. These molecules react to the microwave field in much the same manner as a compass needle reacts to a magnet. If you place a magnet to one side of the compass, the needle will then point to the magnet. If you then move the magnet to the other side of the compass, the needle will turn and again point to the magnet. When this process is repeated quickly and many times, eventually the friction in the bearing that supports the needle will heat the bearing.

The molecules in food react in a very similar manner to the changing microwave field; that is, the molecules tend to align themselves with the field. The molecules that make up the food which is cooked in the microwave oven are

rotated from their starting position to 180° from their starting position and back to their starting position 2,450 million times a second. (This rate depends upon the operating frequency of the oven and can vary from oven-to-oven. This constant and rapid rotation causes the food to get hot. As the microwaves penetrate the food, power is lost to each successive layer of molecules. The center molecules, therefore are not rotated a full 180° and less heat is generated towards the center of the food than at the outside of the food.

Contrary to popular belief, food prepared in a microwave oven is not cooked from the inside out, but is cooked all the way through at the same time with more cooking being performed on the exterior of the food. It is, therefore, possible to prepare a rare, medium, or well done roast in a microwave oven.

The fact that food is heated throughout makes it possible for the microwave oven to cook food fast. Time required to cook an item in the microwave oven is solely dependent upon how much heat is required, and in turn the amount of heat required of the food and the weight of the food. In conventional cooking, only the surface of the food is heated directly by the oven or grille. The heat required to cook the inside portion has to be conducted from the surface.

Three factors govern the time required to cook an item in the more conventional way. A minor one of these is how much heat is required. The major ones are, how well does the food conduct heat, and how much can the surface be overheated without causing serious defects. For example, let's take water. Water is a good conductor of heat and the surface can be overheated without deterioration, therefore, water can boil fairly quickly on a range. On the other hand, let's take milk. Milk is also a good conductor, but the surface cannot take overheating. If you try to boil milk quickly, the milk will burn, therefore, milk has to be cooked slowly. Cake is an example of a food that conducts heat poorly. Although a small amount of heat is required to bake a cake, it must be cooked rather slowly because the conduction to the center is poor.

## Oven circuits used today

A typical circuit for a microwave oven can be seen on



# way to cook

*can cook foods fast.*

*how it works*



**TAPPAN 56-1139 microwave oven with some of the many foods it can cook.**

page 70. You will note that the magnetron is the heart of the oven. It is the device that converts dc power into rf cooking energy. Magnetrons operate from a high voltage source (about 4000 volts dc) and a low ac voltage (3-volt heater supply) and in a magnetic field. The tube itself consists of a plate, cathode and heater.

For the tube to operate, electrons must flow through the tube from the cathode to the plate. To get the electrons to flow, high voltage must be applied between the cathode and plate and the cathode must be heated by a heater.

So far what we have described could fit a diode. To convert this diode into a magnetron, a magnetic field is applied parallel to the cathode. This field causes the electrons to spin around the cathode instead of merely traveling from the cathode to the plate.

The spinning action of the electrons and the physical shape of the plate causes rf currents to flow on the surface of the plate. An antenna connected to the plate directs the rf power to flow from the plate down the waveguide into the oven cavity.

## Safe microwave cooking

All microwave ovens have several built-in safety devices. The idea is to prevent the oven from being operated whenever the door is open and to prevent excessive microwave radiation from reaching the oven exterior.

To start, all microwave ovens include interlock switches that turn off the magnetron when the oven door is opened. Some ovens have a physical lock that does not permit the user to open the door at all while the oven is on.

A second type of precaution protects the magnetron against damage. It is a time-delay circuit that delays the application of high-voltage for at least 15 seconds. This gives the magnetron heater time to warm up before high-voltage is applied. Also, there is usually a thermal cutout that turns the oven off if the magnetron overheats.

Once generated, the microwaves must be contained so that only the food is cooked. A combination of several techniques is used to insure this. The oven cavity is usually made of stainless steel which reflects microwave energy and does not absorb any power. Aluminum will do the same job and is sometimes used.



**AMANA RADARANGE is another countertop microwave oven being made today.**

The door seal must also prevent the passage of microwave energy. Three basic types are used. The first is a metal-metal pressure seal. This type depends upon a metal-to-metal contact and its effectiveness depends upon maintaining a good contact between the pressure plate and the cavity-door interface. Aging, denting, or grease accumulations on the metal seal can deteriorate the contact and cause leakage to increase.

A capacitive pressure door seal is also used. It differs from the metal-metal seal in that it has a thin layer of dielectric material covering the contact plate. At microwave frequencies this capacitive plate acts in the same manner as the metal-metal seal. The dielectric coating however, increases the cavity-door interface breakdown potential and therefore reduces the possibility of arcing between the door and the cavity.

A choke door seal in the third type. It works on the waveguide principle that a short circuit termination must have zero voltage and maximum current, while  $\frac{1}{4}$  wavelength away the current will be zero with the voltage at a maximum. With the current at zero at the door edge, the radiation is also zero, so no leakage is possible. Usually the quarterwave slot formed around the door is filled with some dielectric material so that food cannot get into the choke seal.

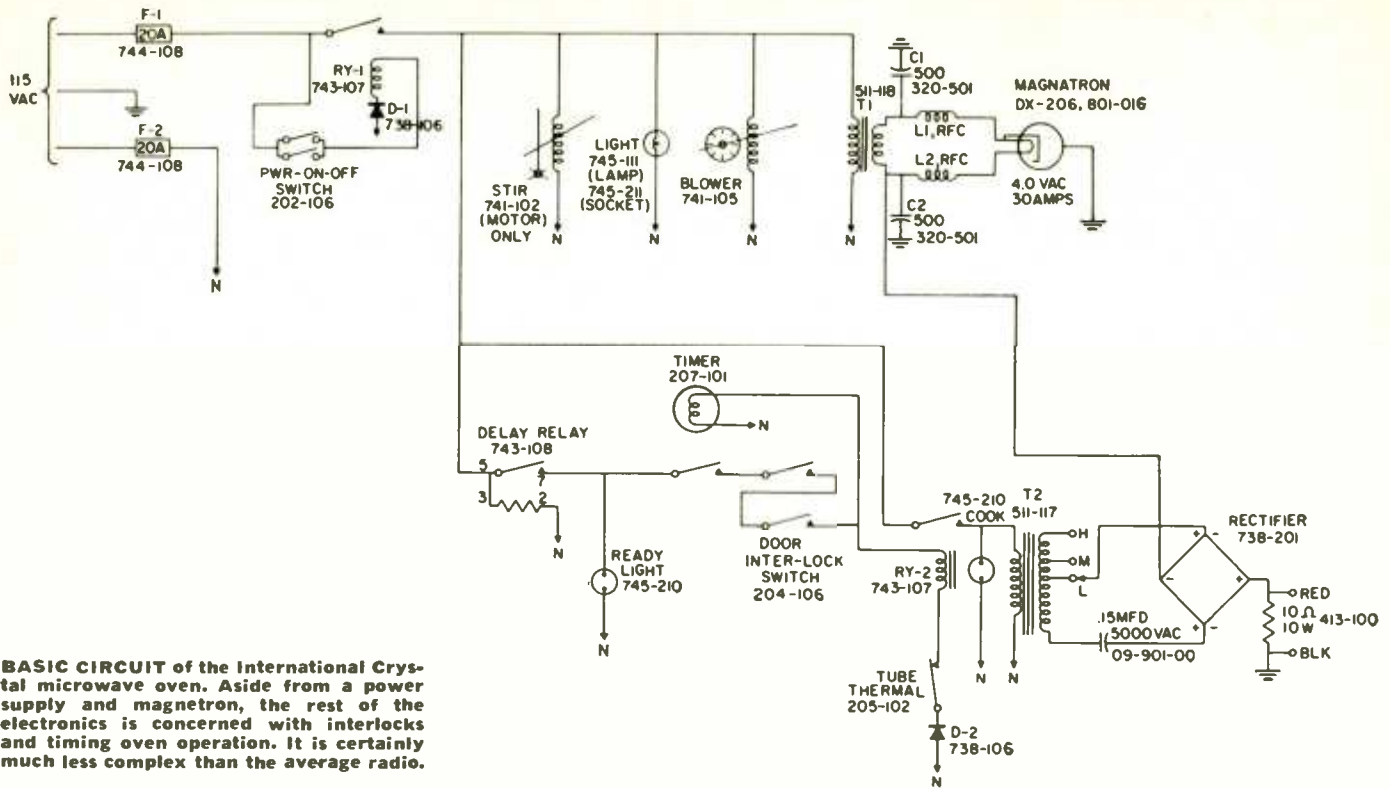

**BASIC CIRCUIT** of the International Crystal microwave oven. Aside from a power supply and magnetron, the rest of the electronics is concerned with interlocks and timing oven operation. It is certainly much less complex than the average radio.

### Everyday repair guide

If you are called upon to service an oven here are some guide lines to follow. They cover most common faults.

Trouble	Remedy
Blower, light, and stirrer do not start when power switch is pushed.	Check house circuit breaker and for power at the wall outlet being used. Check fuses inside the oven.
READY light OK but COOKING light does not come on when Timer started.	Interlock not closed. Check to see that door is closed completely.
COOKING light comes on and oven operates, but quits after a few minutes.	Insufficient air through magnetron causing temperature to actuate protective cutout. Check blower for dirt, and ventilation around oven.
Arcing in top of oven around stirrer.	Oven operating with insufficient load in the chamber.
Oven seems to be cooking slow.	Check line voltage at outlet while oven is operating.
READY and COOKING lights work OK but oven does not seem to be cooking.	Check magnetron current.

### Microwave radiation hazards

When inspecting a microwave oven prior to repair there is always the danger of improper operation causing potential exposure to excessive radiation. This can most easily occur if the interlocks are not operating properly. To protect against this hazard, never open the oven door of a microwave oven unless the high-voltage supply is off. You can determine if it is off by checking the cooking timer. If this timer is at zero, the magnetron is not operating. Don't rely on the interlock to cut off the oven, it may not be working.

Some ovens use a perforated metal screen over the door panel to permit viewing the interior. It is important that you do not poke any metal objects through these openings. A metallic object could act as a receiving antenna in the cavity of an operating oven while the other end could act as a transmitting antenna.

### Above all, be careful

Two final cautions. Never operate the oven with the oven door open and the interlocks disabled. Microwave energy from an oven can be extremely dangerous. It only takes a short exposure to cause an injury. Don't expose yourself or anyone else to it.

Last, the magnetron has strong permanent magnets in its frame. Sharp blows can cause the magnetic field to change, affecting tube operation. If the air chambers are removed, be extremely careful to protect the magnets against damage.

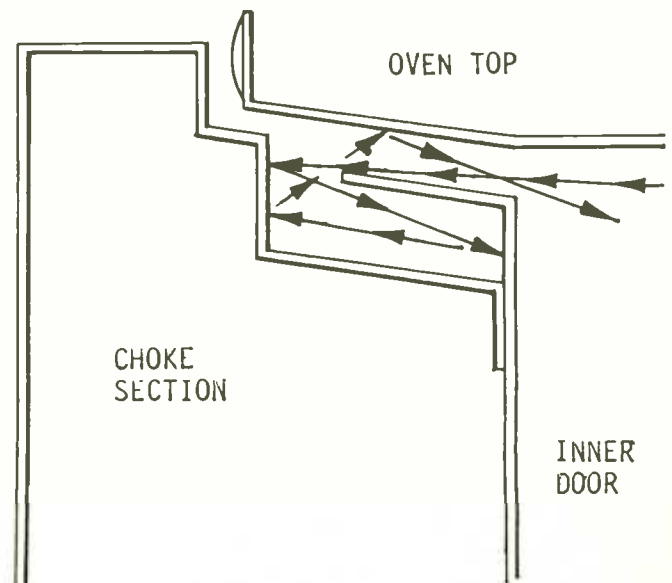

**CHOKE-TYPE DOOR SEAL** action is illustrated in this diagram. This is an effective method used in microwave ovens.

Microwave ovens are still new and are likely to become commonplace. In the interim we will keep you informed on all the latest developments in this expanding new field.

R-E



# Important New SAMS Books



## Color-TV Field-Service Guides

These invaluable guides have been compiled to enable the technician to service color-TV more efficiently in the customer's home. Charts provide chassis layouts showing type, function, and location of all tubes and/or transistors used in a particular chassis, ratings and locations of fuses and circuit breakers, location of service controls and adjustments, etc. Specific field-adjustment procedures are shown on page opposite chassis layout. Index provides instant reference to the proper chart for any particular TV chassis. Each volume contains 80 diagrams covering over 3,000 chassis.

Volume 1. Order 20796, only . . . \$4.95  
Volume 2. Order 20807, only . . . \$4.95

## Questions and Answers

### About Medical Electronics

by EDWARD J. BUKSTEIN Anyone familiar with basic electronic circuits will find this a fascinating and readily understandable book emphasizing the applications of electronic equipment in clinical and research medicine, general principles of equipment operation, special features of the equipment, and the related medical terminology.

Order 20816, only . . . \$2.95

### ABC's of Integrated Circuits

by RUFUS P. TURNER. This basic introduction to the integrated circuit (IC) will be welcomed by hobbyists, experimenters, and students who have some familiarity with semiconductors. Describes the fundamentals of the IC, and its applications in amplifiers, oscillators, control circuits, communications, test equipment, and computers.

Order 20823, only . . . \$2.95

### Transistor Specifications Manual. 4th Ed.

by THE HOWARD W. SAMS ENGINEERING STAFF. Lists the electrical and physical parameters (along with the manufacturers) of virtually all of the transistor types now in use. Also includes frequency, gain, and leakage parameters, as well as a special section on rf power transistors. Comb-bound.

Order 20788, only . . . \$4.50

### ABC's of FET's

by RUFUS P. TURNER. Clearly explains the theory and describes the operating principles of FET's (field-effect transistors), special semiconductor devices with unique qualities. Describes FET circuit design and typical applications in a number of practical circuits.

Order 20789, only . . . \$2.95

## Computer Data Handling Circuits

by ALFRED CORBIN. This book offers the beginner a valuable introductory course in practical digital data circuit analysis. Makes understandable the semiconductors and circuitry used in digital equipment. Explains digital data logic and the associated mathematics. Analyzes the basic logic circuits and their functional blocks, as well as digital display devices. Invaluable for anyone desiring to be conversant in the operational theory of data handling circuits.

Order 20808, only . . . \$4.50

## Color-TV Case Histories

by JACK DARR. Case histories not only provide the TV technician with solutions to troubles he is likely to encounter, but enable him to compare his troubleshooting methods with those of others. Each of these case histories of troubles actually happened. The symptoms are given for each trouble, along with the method used to locate it.

Order 20809, only . . . \$3.50

## Radio Spectrum Handbook

by JAMES M. MOORE. This book fills the "information gap" about the many types of radiocommunication which exist apart from radio and TV. Each chapter covers a given frequency-allocation range; a table provides an overall summary of the uses of all frequencies in that range, followed by text describing the individual radio services available. Includes information on receivers available for the various frequency bands described. Hardbound.

Order 20772, only . . . \$7.95

## First-Class Radiotelephone License Handbook. Third Edition

by EDWARD M. NOLL. Completely updated to cover all the new material included in the recently revised FCC Study Guide. Book sections include: Theory and discussion of all phases of broadcasting; all the questions (and the answers) included in the FCC Study Guide; three simulated FCC examinations; appendices containing the most relevant FCC Rules and Regulations. This book will not only help you acquire your license, but will also serve as a textbook for broadcast engineering training.

Order 20804, only . . . \$6.50

## Short-Wave Listener's Guide. 4th Ed.

by H. CHARLES WOODRUFF. Completely revised and enlarged to include the most recent changes in SW broadcasting schedules. Lists world-wide short-wave stations by country, city, call letters, frequency, power, and transmission time. Includes Voice of America and Radio Free Europe stations, and stations operating behind the Iron Curtain. With conversion chart and handy log.

Order 20798, only . . . \$2.95

## ABC's of Tape Recording. 3rd Ed.

by NORMAN CROWHURST. Newly revised and updated edition of this popular handbook. Explains how tape recorders work (transport mechanisms, heads, controls, etc.), how to choose the best recorder for your needs, and how to use it most effectively for both entertainment and practical purposes. Includes tips on recording quality and recorder care.

Order 20805, only . . . \$2.95

## HOWARD W. SAMS & CO., INC.

Order from your Electronic Parts Distributor, or mail to Howard W. Sams & Co., Inc., Dept. RE-021  
4300 W. 62nd St., Indianapolis, Ind. 46268

Send books checked at right. \$\_\_\_\_\_ enclosed (please include sales tax where applicable).

Send FREE 1971 Sams Book Catalog

Name \_\_\_\_\_  
PLEASE PRINT

Address \_\_\_\_\_

City \_\_\_\_\_ State \_\_\_\_\_ Zip \_\_\_\_\_

<input type="checkbox"/> 20796	<input type="checkbox"/> 20808
<input type="checkbox"/> 20807	<input type="checkbox"/> 20809
<input type="checkbox"/> 20772	<input type="checkbox"/> 20789
<input type="checkbox"/> 20816	<input type="checkbox"/> 20804
<input type="checkbox"/> 20823	<input type="checkbox"/> 20798
<input type="checkbox"/> 20788	<input type="checkbox"/> 20805

Circle 18 on reader service card

# NEW PRODUCTS

More information on new products is available from the manufacturers of items identified by a Reader Service number. Use the Reader Service Card on page 93 and circle the numbers of the new products on which you would like further information. Detach and mail the postage-paid card.

**STYLUS FORCE GAUGE, model SFG-2**, is based upon a counterweight balance principle, no springs are used. It measures stylus pressure with the pickup arm in playing position and is accurate within  $\frac{1}{10}$  of a gram in the optimum tracking range of  $\frac{1}{2}$  to  $1\frac{1}{2}$  grams. If

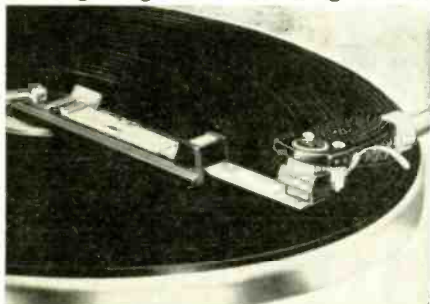

stylus force exceeds  $1\frac{1}{2}$  grams, the stylus is placed in a second channel which makes it possible to get an extended force measurement of up to 3 grams. \$4.95.—Shure Bros, Inc. 222 Hartrey Ave. Evanston, Ill. 60204.

Circle 31 on reader service card

**DIGITAL READOUT FREQUENCY COUNTER KIT, model 1B-101**, uses computer-type integrated circuitry to provide accurate counting from 1 Hz to over 15 MHz and eliminate divider chain adjustment. Readings to the nearest kHz are made with the range switch in the kHz position. Switching to the Hz position allows reading figures down to



the last Hz. Five-digit readout plus over-range indicator. The input circuit uses a dual-gate, diode-protected MOSFET to provide proper triggering from less than 100 mV to greater than 200 volts, without input level adjustment. Input impedance is 1 megohm shunted by less than 20 pF to minimize circuit loading and error. Kit \$199.95.—Heath Co. Benton Harbor, Michigan 49022.

Circle 32 on reader service card

**KINETIC ART FORM LAMPS, AtmoSpheres**, creates the illusion that the lamp itself is moving. The pattern spins around an assembly of transparent, color light bulbs that blink on and off. The globe-type *AtmoSpheres* are available as table lamps in 8-, 12-, 16-, and 24-inch diameters. The two largest ones have

plastic globes, are motor driven and available in hanging models. The smaller sizes have glass globes and are heat

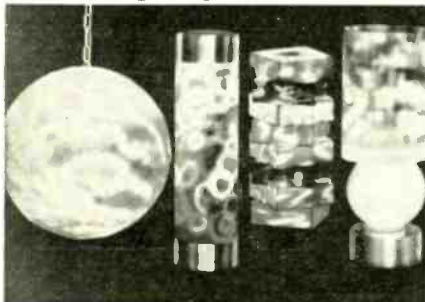

driven. Other models include the "Color Column," the "Pagoda Light," and others. Replacement masks that change the effects of the images are available.—Edmund Scientific Co., 380 Edscorp Bldg., Barrington, N.J. 08007.

Circle 33 on reader service card

**UHF CONVERTERS, models 6715, 6714**, have transistor inputs with low noise figures for maximum signal-to-noise ratio, and snow free pictures. Vernier slide rule tuning for channel selection. The 6715 includes a uhf preamplifier and an illuminated dial. It is recom-



mended for fringe areas. The 6714 is similar, but has no amplifier, and is recommended for metropolitan and suburban areas. \$25.95 and \$19.95 respectively.—Channel Master, Ellenville, N.Y. 12428.

Circle 34 on reader service card

**340-WATT STEREO RECEIVER, model SX-2500**, features automatic search tuning. While station hunting, a muting switch cuts out interstation noise. There is also an adjustable muting level control for presetting the amount of muting between FM stations. Another fea-

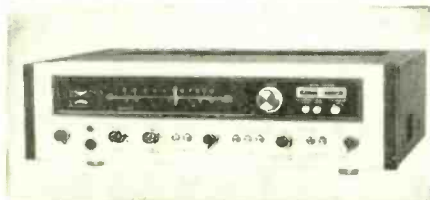

ture is the FM stereo selector switch, which when on, causes the tuning feature to stop only on stations broadcasting stereo. Remote control unit for automatic

tuning and volume control. FM tuner has a two-stage rf circuit and uses a FET's, 5 IC's, 2 crystal filters, and a 4-gang variable capacitor. Sensitivity is 1.6  $\mu$ V/meter. Capture ratio is 1 dB at 98 MHz. Antenna input is 300 ohms balanced and 75 ohms unbalanced. There are two phono inputs. \$549.95—Pioneer Electronics, 140 Smith St, Farmingdale, L.I. New York. 11735.

Circle 35 on reader service card

**TYMETER NUMERAL CLOCK, model Essex #171**, is a 110-120 V, 60 cycle, ac clock. Measures 4" x 7" x 3" and weighs 3 pounds. Housed in a plastic case—walnut or white—it has a 3-D re-



cessed white face and gold trimmed escutcheon. \$16—Tymeter Electronics, Div. of Pennwood Numechron, 7249 Frankstown Ave., Pittsburgh, Pa. 15208.

Circle 36 on reader service card

**TUNER LUBRICANT AND CLEANER, Super Lube, and Super Spray Bath**, are approved for both color and black and white TV sets. *Super Lube* foam cleans, lubricates and restores while polishing tuner contacts. Will not cause drift or detuning. *Super Spray Bath* dissolves accumulated grease, dirt, oil and oxidation



and restores tuners. Can be used on all types of electronic equipment. Both products are non-flammable and non-toxic. *Super Lube* comes in an 8 oz. spray can, *Super Spray Bath* in a 24 oz. spray can. \$2.35 and \$3.25, respectively.—Electronic Chemical Corp. Jersey City, N.J. 07304.

Circle 37 on reader service card

**PLASTIC KNOBS, Model PKS-90B-10**, has a .937" knob diameter with a dial skirt size of 1.437". A brass insert accepts  $\frac{1}{8}$ " shaft and includes a 6/32 set screw. The dial skirt is natural finished





# NEW exciting home training to be a **COMPUTER TECHNICIAN**

NRI program includes a complete, operating computer, with memory, to make you thoroughly familiar with computer organization, design, operation, construction, programming, trouble shooting and maintenance.

You build your own digital computer step-by-step, circuit-by-circuit. You really get involved as you learn computer organization, operation and programming with this remarkable new training aid. It performs the same functions as bigger commercial computers—and it's yours to keep and use.

What better way to learn all about computers than to actually build and use one? That's exactly what you do in NRI's new Complete Computer Electronics home training program.

What you see illustrated may very well be the most unique educational aid ever developed for home training. This is not simply a "logic trainer." It is literally a complete, general purpose, programmable digital computer that contains a memory and is fully automatic. It's a small-scale model of larger, expensive commercial computers. Once you build it and it is operational, you can define and flow-chart a problem, code your program, store your program and data in the memory bank. Press the "start" button and, before you can remove your finger, the computer solves your problem and displays the results.

NRI is offering this new course because this is only the beginning of the "Computer Age." The computer industry continues to leap ahead. Qualified men are urgently needed, not only as digital technicians and field service representatives, but also to work on data acquisition systems in such fascinating fields as telemetry, meteorology and pollution control. Office equipment and test instruments also demand the skills of the digital technician. This exciting NRI program can give you the priceless confidence you seek to walk into a technician's job and know just what to do and how to do it.

*You learn with your hands as well as your head* Planned from the beginning to include training equipment in the pioneering NRI tradition, this exceptional new course combines kits with educator-acclaimed NRI "bite-size" texts in an easy-to-understand package. But, unlike other home training, this is not a general electronics course. Lessons have been specifically written to stress computer repair. You perform a hundred experiments,

build hundreds of circuits, use professional test equipment. You build and use your own solid-state, transistorized volt-ohmmeter and your own oscilloscope in addition to your digital computer. Because you work with your hands as well as your head, your training is as much *fun* as it is education.

## *Train at home with the leader*

There is so much to tell you about this latest NRI "first" in home training, you must fill out and mail the coupon today. Get the full story of Complete Computer Electronics and the amazing digital computer you build and use as you learn. The free NRI Catalog you receive also tells you about other NRI training plans in Color TV Servicing, Communications, Electronics Technology. There is no obligation. No salesman will call on you. NATIONAL RADIO INSTITUTE, Washington, D.C. 20016.

### MAIL NOW FOR FREE CATALOG



**NATIONAL RADIO INSTITUTE**  
Washington, D.C. 20016

94-021

Please send me your FREE CATALOG with details about new Complete Computer Electronics training. (No salesman will call)

Name \_\_\_\_\_ Age \_\_\_\_\_

Address \_\_\_\_\_

City \_\_\_\_\_ State \_\_\_\_\_ Zip \_\_\_\_\_

ACCREDITED MEMBER NATIONAL HOME STUDY COUNCIL

this slab from the positive biased drain to the relatively negative source.

The gate and source are normally the input terminals of the FET. Thus the gate-source junction is forward biased so the gate is made at least 0.6 volt positive with respect to the channel. (Remember, from a previous article, that we need at least 0.6V for a forward-biased diode to conduct.) There is conduction between the gate and the channel. The input impedance would be that of a forward-biased diode. But this junction is normally reverse biased. The negative voltage controls the quantity of current flowing from the source to the drain. An increase in negative voltage reduces the source-drain current.

Should the channel be made of a p-type semiconductor and the gate of n-slabs, the resulting configuration is the p-channel transistor. The schematic change is but a reversal of the arrow representing the gate. The operation is exactly as described above for the n-channel device. However, here the bias must be reversed to make the drain negative and the gate positive with respect to the source.

As the input impedance is high the FET is a voltage-activated device. Whereas  $\beta_{ac}$  is the ratio of currents,  $\Delta I_c / \Delta I_b$ , the ac gain here is the ratio of the change of drain current,  $\Delta I_D$ , to the change of gate voltage,  $\Delta V_G$ . This ratio is known as transconductance. Using the symbol  $g_m$  for this factor

$$g_m = \frac{\Delta I_D}{\Delta V_G} \quad \text{Eq. 7}$$

Assume for the moment, that you have a transistor with a transconductance of 5000 micromhos (equal to 0.005 mhos). If you apply 0.2 volt ac between the gate and source, the output drain current is  $0.2 \times 0.005 = 0.001$  amp ac = 1 mA ac. The ac voltage developed across a load resistor is the drain current flowing through that resistor multiplied by the 1 mA.

Relative even to the JFET, the input impedance of the IGFET is extremely high. The magnitude of this impedance can be realized when it is noted that a static charge is frequently induced at the various elements of the device. (Large amounts of static charge can be generated only across extremely high impedances.) This static voltage is so high that it requires special precautions to be taken when handling an IGFET. To avoid damage to the IGFET due to the static charge, all leads must be shorted together until after the IGFET has been soldered into its circuit.

The physical structures of the n

and p channel depletion type of IGFET, along with the schematic representation of each, are shown in Fig. 6. The discussion will center around the n-channel device. Once again, everything will refer to the p-channel transistor as well. Only the types of material and the polarities of the applied voltages are reversed.

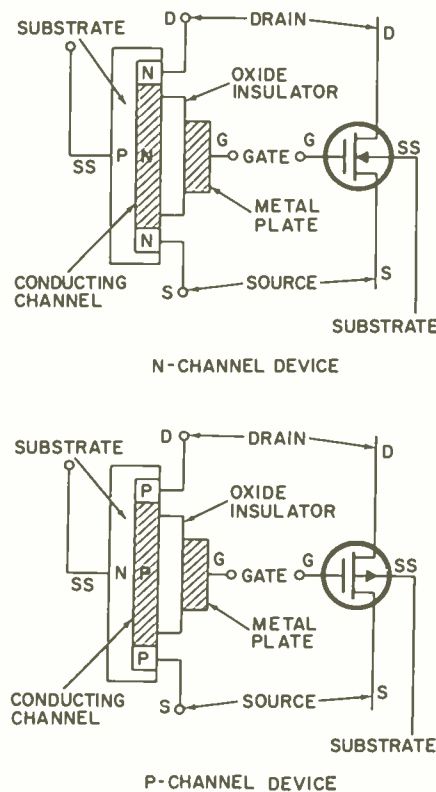

**FIG. 6—PHYSICAL MAKEUP AND SYMBOLS of depletion-mode insulated-gate field-effect transistors.**

Two n-slabs of the n-channel IGFET are diffused into or put in intimate contact with a highly resistive p-semiconductor foundation, known as a substrate. A medium-resistance n-type material connects the two n-slabs. One of the two n-slabs serves as the source and the other n-slab is the drain. The gate is made out of metallic material and is insulated from the semiconductors by an oxide. If the drain is made positive with respect to the source, current flows between the two semiconductors. A negative voltage on the gate will affect the amount of source to drain current flow. The current will be reduced as the gate is made more negative with respect to the source. This is referred to as the depletion mode of operation.

An additional feature of the IGFET over the junction type of transistor is that more source to drain current flows as the gate is made more positive. The IGFET gate can actually be made positive with respect to the source. This positive bias will not reduce the input impedance since the gate material does not form a junction

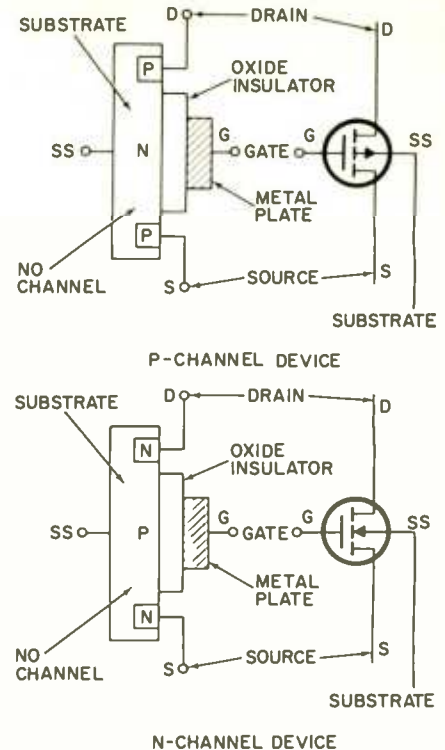

**FIG. 7—SYMBOLS AND PHYSICAL MAKEUP of enhancement-type FET's. There is no channel between the drain and the source.**

with the channel, but is physically insulated from it by the oxide. When biased positively, the transistor is said to be operating in the enhancement mode.

Some IGFET's are strictly enhancement types. A drawing of this type is shown in Fig. 7. The drawing is similar to the drawing of the types just discussed with the exception that there is no n-channel connecting the source to the drain. Current flows between the source and drain only when the positively biased gate induces negative charges into the p-substrate. This reduces the resistance between the two n-slabs allowing conduction.

As for gain, the definition of  $g_m$  discussed for the JFET applies here as well. The example discussed above does not change for this type of transistor—only the voltages involved at the gate have the additional flexibility of being either positive or negative. The substrate lead is normally tied to the source.

In all types of FET's, there is also a dc transconductance characteristic, written  $g_{FS}$ . This defines the ratio of dc drain current flow to the dc gate-to-source voltage.

### Biasing

Many transistor circuits can be understood and the explanations inferred from the above discussion. Proper bias is an important factor when designing any circuit using these devices. Bias methods will be discussed in the next installment of this series. **R-E**



anodized machined aluminum with counter-clockwise 0-10 markings having 30° spacing. The dial is available with-



out the 0-10 markings and has an arrowhead indicator. 55¢ each.—Aleo Electronic Products, P. O. Box 1348, Lawrence, Mass. 01842.

Circle 38 on reader service card

**AUTOMATIC TURNTABLE LINE**, includes the *Professional Series*, featuring the 610—the top of the line—and the MP60, a manual turntable with automatic tonearm set-down and shut-off. The *Promotional Series* offers models 310 (illustrated) and 5500; budget priced. The *Minichanger Series* consists



of miniature sized units to fit tight spaces. All models in the three series

consist of a pre-installed cartridge, molded ebony vinyl walnut base, and a tinted dust cover.—BSR McDonald, Div. of BSR, USA, Ltd., Route 303, Blauvelt, N.Y.

Circle 39 on reader service card

**SWEEP/MARKER GENERATOR**, Speed Aligner SM158. Intended to simplify aligning i.f. and chroma amplifiers in any color TV, and to check the tuner. Hook up four leads labeled TO TV and TO SCOPE. Only two major controls. All markers are crystal controlled and



automatic. It is no longer necessary to look up carrier frequencies or channel frequencies. When crystal marker buttons are pushed the rf, i.f. or chroma markers will pop on the curve at correct frequency. \$275.—Sencore Inc., 426 S. Westgate Dr., Addison, Ill. 60101.

Circle 40 on reader service card

**4-CHANNEL RECEIVER**, model 701. Uses integrated circuits throughout AM and FM sections (a total of 14 IC stages). Pushbutton electronic tuning

without moving parts is provided by an Autosean circuit with four dual varactor diodes. Featuring overload capacity of 2,000,000 microvolts and 105 dB spurious response rejection. The unit is a



four-channel amplifier which also functions as a flexible two-channel unit. Four-channel listening in a second room, through a remote set of four speakers, is available at the throw of a switch. Separate four-channel controls for bass, treble, balance, high filter, loudness contour and tape monitor. Maximum output from the four amplifiers is 250 watts music power, Rms power is 40 watts per channel.—Fisher Radio, Long Island City, New York 11101.

Circle 41 on reader service card

**CB BASE STATION**, Citation. Features a digital clock with a turn-on timer that can be programmed to operate at a pre-



OUR STORE  
AT YOUR DOOR

**Olson**  
ELECTRONICS  
**FREE**  
Catalog

Fill in coupon for a FREE One Year Subscription to OLSON ELECTRONICS Fantastic Value Packed Catalog — Unheard of LOW, LOW PRICES on Brand Name Speakers, Changers, Tubes, Tools, Stereo Amps, Tuners, CB, Hi-Fi's, and thousands of other Electronic Values. Credit plan available.

NAME \_\_\_\_\_  
ADDRESS \_\_\_\_\_  
CITY \_\_\_\_\_ STATE \_\_\_\_\_  
GIVE ZIP CODE \_\_\_\_\_

If you have a friend interested in electronics send his name and address for a FREE subscription also.

**OLSON ELECTRONICS**  
Dept. LN 260 S. Forge Street  
Akron, Ohio 44308

Circle 62 on reader service card

## Need high temperatures in tiny places?

The amazing Little Torch is so tiny it can throw a flame of 6300°F. through the eye of a needle. It solders, brazes, welds and heats with exacting precision in the smallest places; uses oxygen and acetylene,

hydrogen, propane, natural gas or Mapp. It's available with five tips ranging in size from one large enough to weld 16 ga. steel to one small enough to weld .002" copper wire. For free brochure write to:

The  
"Little Torch"

**Tescom**  
CORPORATION

Instrument  
DIVISION



Dept. 2SS-1, 2633 S.E. 4th St., Minneapolis, Minnesota 55414

Circle 61 on reader service card





## Nothing replaces the reality of personal "in-class" instruction.

It builds your confidence through thorough preparation.

Professional success depends upon the quality of your training. You owe yourself the best. Anything less will be costly, takes much longer and requires more effort from you.

Take the shortest distance between you and your career. You'll be ahead in every day.

FREE LIFETIME PLACEMENT  
VETERAN APPROVED



## HEALD Engineering College

1215 Van Ness Ave.,  
San Francisco, California 94109

Oldest and Largest Institution of its kind in the United States. (Since 1863)

Please send information on:

### HEALD ENGINEERING COLLEGE

Bachelor of Science Degree Courses (36 months)

- Electronic Engineering
- Electrical Engineering
- Mechanical Engineering
- Civil Engineering  Architecture (42 months)

### HEALD INSTITUTE OF TECHNOLOGY A division of Heald Engineering College

Technology Diploma Courses

- Electronic Engineering Technician (FCC) (15 months)
- Radio-Television Technician (FCC) (15 months)
- Mechanical Drafting (12 months)
- Electrical Drafting (12 months)
- Structural Drafting (12 months)

Name \_\_\_\_\_ Age \_\_\_\_\_

Address \_\_\_\_\_

City \_\_\_\_\_

State \_\_\_\_\_

Zip \_\_\_\_\_ Phone \_\_\_\_\_

Circle 64 on reader service card

selected time. Colored indicator lights indicate modulation, transmission and reception. Crystals for all 23 channels are supplied. An automatic noise limiter reduces ignition noise during reception of weak signals. Provides 100% modulation for full talk power. Equipped with auxiliary speaker/phone jack and a built-in PA system with volume control. \$229.95.—Courier Communications, 100 Hoffman Place, Hillside, N.J. 07205

Circle 42 on reader service card

**DESOLDERING TOOL**, Soldapullit eases component rework through rapid removal of unwanted solder from joints. Recently improved by adding a plastic sleeve to



shield exhaust ports from user. Larger and lighter loading knob for easier loading. \$5.95, including illustrated 12 page instruction manual.—Edsyn Inc. 15954 Arminia St. Van Nuys, Calif. 91406.

Circle 43 on reader service card

**BURGLAR ALARM SYSTEM**, model 7100 is a solid-state, radar system operating in the 400-MHz range. Provides total protection for up to 3500 square feet. Sustained human movement for 4 seconds or more energizes alarm relay contacts. The ON/OFF switch circuit is impedance controlled and shorting or cutting the cable will result in alarm. May be powered either from 110 Vac or 12 Vdc, is



## MISSILE BATTERY

The Only Lifetime Battery

Surplus—Ni-Cad plastic sintered-plate battery cells at approx. 10% of government cost

Connect these 1.2 V. cells in series to make batteries of any voltage. (Example: 10 cells = 12 V. Batt.) or size to replace storage batteries on autos, motorcycles, boats, radio, etc. All the good characteristics not possessed by lead-acid and other alkaline batteries such as: Lifetime service, lighter wgt., constant voltage, high discharge rate (approx. 10 times All cap.), operate at 100% cap. in temp. range -47° to +165°F., not harmed by storage, discharge, overcharge, or freezing. May be charged thousands of times with the only maintenance of adding distilled water and keeping clean. Select cell sizes to fit your application below.

Type	AMP Hr	High	Width	Deep	Wgt. Oz.	Cost
AH4	4	6	2	1/2	6	1.49
AH4	4	6	2	1/2	6	2.95
AH6	6	4	2-1/8	15/16	8	1.79
AH6	6	4-5/8	2-5/8	3/4	8	1.79
AH6R	6	4-1/2	2-5/8	11/16	8	2.95
AH10	10	4-3/4	2-3/4	1-3/16	16	2.29
AH10	10	4-3/4	2-3/4	1-3/16	16	4.95
AH12	12	5-3/4	2-5/16	1-1/16	18	2.79
AH34	34	9-1/4	3-1/8	1-3/8	52	4.95
AH60	60	11-1/4	5	1-3/8	104	5.95

### SPECIAL CLOSE OUT!

Metal cased Ni-Cad cells. Ideal for motor starting.  
30AHM-30AH. 8-7/8x3x1-1/4. Wgt. 3-1/2 lbs. \$2.00  
52AHM-52AH. 9x3x1-5/8. Wgt. 4-1/2 lbs. \$3.50  
Send for complete list including made-up batteries. All cells guaranteed for satisfaction or money back. All cells not marked now are used but serviceable. Include postage on parcel post shipments.

### ESSE RADIO COMPANY

Dept. RE-2  
368 S. Meridian St.  
Indianapolis, Ind. 46225

Circle 65 on reader service card

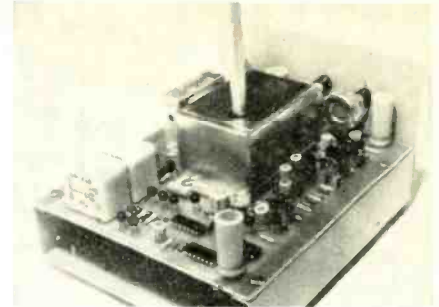

easily camouflaged, and can stand alone or be used as part of larger system. Artronix Surveillance, 716 Hanley Industrial Court, St. Louis, Mo. 63144.

Circle 44 on reader service card

**STEREO AMPLIFIER**, Dual 50A amplifier features 5-year warranty. Patented circuitry provides high music definition into complex speaker loads. \$440. Also SP-2 preamplifier, an extremely low distortion stereo control unit (\$395.00) and

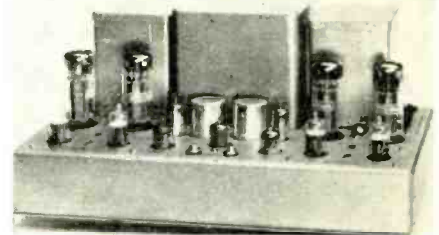

SP-1A preamplifier with electronic voltage regulation and additional variable equalization (\$750.00).—Audio Research Corporation, 2843 26th Avenue South, Minneapolis, Minn. 55406.

Circle 45 on reader service card

Write direct to the manufacturers for information on the following item.

**PEGBOARD TOOL HANGERS**, snap into 1/4" pegboards providing space for tools, parts and supplies at easy reach. Two 9" long tool holders can accom-

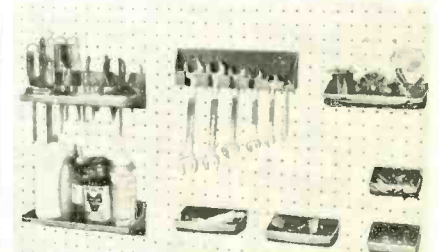

modate screw drivers, pliers, wrenches, etc. A 9" shelf holds boxed, bottled or canned items. Part bins come in 7", 5" and 3 1/2" sizes. All pieces are made of high-impact plastic. 20¢ to \$1.00 per item. Sample kit with 6 pieces, \$3.50.—Wickliffe Industries, Inc. P.O. Box 286, Wickliffe, Ohio 44092 R-E

### CASSETTES GOT YOU PUZZLED?

Next month Larry Allen presents a programmed article on the electronics in cassette tape recorders. Step-by-step he details how these new tape machines operate; and how you can keep them operating. Be sure you get the March 1971 issue of RADIO-ELECTRONICS.



# NEW LITERATURE

All booklets catalogs, charts, data sheets and other literature listed here with a Reader's Service number are free for the asking. Turn to the Reader Service Card on page 93 and circle the numbers of the items you want. Then detach and mail the card. No postage required!

**STEREO COMPONENTS CATALOG**, is a convenient reference source. Lists receivers, AM/FM stereo tuners, amplifiers, preamplifiers, reverberation amplifiers, equalizer preamps, speaker systems, turntables, tape decks, and headphones. Gives complete electronic and mechanical specifications of each listed component. Each item listed is illustrated. Price, weight, and space occupied is also presented.—Pioneer Electronics, 140 Smith St., Farmingdale, N.Y.

Circle 47 on reader service card

**CROSS REFERENCE COLOR TV CONTROLS**, No. X67, is a 32 page, vest-pocket size cross reference. Lists replacement color TV controls for convergence, audio, color, age delay, focus, brightness, sensitivity, horizontal frequency and centering, vertical linearity and centering. Book lists replacement for original manufacturer's part. Organized by set maker and original part number.—Workman Electronics, P. O. Box 3828, Sarasota, Fla. 33578.

Circle 48 on reader service card

**ELECTRON TUBES AND SEMI-CONDUCTOR CATALOG**, 1970, 94 pages includes semiconductor diodes, transistors, silicon controlled rectifiers, foreign diodes and transistors, transmitting, industrial and special purpose tubes, radio and TV receiving tubes, and many others.—Starnetics, 10639 Riverside Drive, N. Hollywood, Calif. 91602.

# TUBE TESTER OWNERS

WE HAVE THE LATEST TUBE DATA AND ADAPTERS FOR →

- EICO
- HEATH
- JACKSON
- KNIGHT
- MERCURY
- NRI-CONAR
- PRECISION
- SYLVANIA

Don't let your tube tester become obsolete

CLIP AND MAIL COUPON TODAY

• COLETRONICS SERVICE INC. TD-71  
 • 1744 Rockaway Ave.,  
 • Hewlett, N.Y. 11557  
 •  Enclosed find \$3.50 for latest data.  
 •  Enclosed find \$5.00 for 1-yr. subscription  
 • (Latest Data Plus 2 Supplements.)  
 • Specify Model No. \_\_\_\_\_ Make \_\_\_\_\_  
 • Name \_\_\_\_\_  
 • Address \_\_\_\_\_  
 • City \_\_\_\_\_ State \_\_\_\_\_ Zone \_\_\_\_\_

Circle 66 on reader service card

FEBRUARY 1971

**TOOL CATALOG, NC. Flasher, Fall/Winter**, offers an assortment of precision tools, instruments, and specialty items. In addition to hundreds of special-purpose and hard-to-find tools, there is a listing of tools and test equipment for photographic equipment technicians. Gadgets for home workshops and hobbyists are also featured. Included are a pocket-size measuring microscope, a variety of calipers for inside or outside measurements, and the "Caliputer", a combination slide rule, depth gage and caliper.—National Camera, 2000 W. Union Ave., Englewood, Colorado 80010.

Circle 50 on reader service card

**SEMICONDUCTOR CROSS-REFERENCE GUIDE & CATALOG, Fall, 1970**. Offers germanium transistors, silicon transistors, unijunction, drift field and field effect transistors, silicon rectifiers, dual diodes, zener diodes, triacs, digital IC's, and hardware. Over 25,000 devices listed in 61 pages. Also features important tips on using semiconductors.—Motorola (HEP) Semiconductors, Box 20924, Phoenix, Arizona.

Circle 51 on reader service card

**TV AND RADIO TUBE CATALOG**, Lists a large number of replacement vacuum tubes, stereo headphones, cooling spray, electronic cleaner, microphones, speaker wire, phono arms, grounding adapters, recording tapes multimeters, transistors and many more items.—Cornell Electronics, 4217 University Ave., San Diego, Calif. 92105.

Circle 52 on reader service card

Write direct to the manufacturers for information on the following items.

**COMMERCIAL SOUND PRODUCTS CATALOG**, lists complete specifications for Power Line amplifiers and amplifier accessories, booster and mobile amps, weather proof hi-fi speakers, paging/talkback speakers, reflex trumpets and trumpet accessories, microphones and accessories, and explosion proof drivers. Also includes a sound pressure level chart, sound system design chart, and technical data for public address system designers and installers.—University Sound, 9500 W. Reno, P. O. Box 26105, Oklahoma City, Okla. 73126. R-E

## If you can't come to the world's newest, largest and most exciting electronics department store, we'll mail the store to you!

**Exclusive!** Knight-Kit and Science-Fair Kits. Build-your-own stereo, CB, automotive, ham radio, science, hobby, test, photography and more!

**Exclusive!** Realistic Life-time Tubes. The end of tube worries! We guarantee ours will last as long as your set—or we replace it FREE!

**Exclusive!** Battery-A-Month Club. Join the Club and get a powerful battery every month for a year—FREE



**Exclusive!** Big Choice of Audio Items... Factory-Direct Savings!

Allied TD-1099, 3-Head Stereo Tape Deck. One-piece head makes tape threading a snap. Walnut-grain case. \$179.95

Realistic STA-120, Wideband AM, FET-FM Stereo Receiver, 140 Watts, With case. \$269.95



**1971 Allied Radio Shack Catalog**  
Thousands of electronic values!



Allied Radio and Radio Shack have joined forces to form the largest electronics distributing company in the world! This new 460-page catalog offers you famous-name brands, exclusive new products you'll find nowhere else and prices that only our combined buying power makes possible!

Mail Coupon To Address Below... or bring to Allied Radio Shack store for new 1971 catalog!

**World's Largest! Over 800 stores in 48 states. See your phone book.**

**ALLIED RADIO SHACK, 100 N. Western Avenue**  
Chicago, Illinois 60680

Yes! I want your big new 1971 catalog. I enclose \$1 for mailing and handling (refundable with my first purchase of \$1 or more).

NAME \_\_\_\_\_  
 First Middle Last  
 ADDRESS \_\_\_\_\_  
 Street or Route and Box No.  
 CITY \_\_\_\_\_ STATE \_\_\_\_\_ ZIP \_\_\_\_\_  
 I enclose  check  money order  cash

## 1 New Heathkit solid-state 25" ultra-rectangular Color TV with exclusive MTX-5 Matrix picture tube

This is the world's finest color TV... and you can prove it to yourself. Compare the standard features of the new "371" to any color TV at any price... and you'll agree.

**MTX-5 picture tube... standard.** Developed by Heath engineers in conjunction with leading domestic picture tube manufacturers to provide optimum picture quality. Specially formulated etched glass face plate cuts out unwanted glare... gives increased contrast without sacrificing brightness... delivers the sharpest, purest, most natural 315 sq. in. of color you'll ever see.

**Unique solid-state design...** under development for over 5 years; 45 transistors, 55 diodes, 2 SCR's; 4 advanced Integrated Circuits containing another 46 transistors and 21 diodes; and just two tubes (picture & high voltage rectifier) combine to deliver performance and reliability unmatched in the industry. Modular plug-in circuit boards permit easier assembly & service.

**3-stage solid-state IF... standard...** delivers higher gain for better overall picture quality. Factory assembled & aligned.

**Exclusive design solid-state VHF tuner...** MOSFET design for greater sensitivity, lower noise & lower cross-modulation. Delivers visibly superior color reception. Assembled & aligned.

**Automatic Fine Tuning... standard.** Just push a button and the

assembled & aligned AFT module tunes in perfect picture & sound automatically, instantly... eliminates manual fine tuning.

**VHF power tuning... standard...** scan thru all VHF channels and one preselected UHF channel at the push of the button.

**"Instant-On"... standard.** A push of the power switch brings instant sound, picture in seconds. Preheated picture tube filaments extend picture tube life.

**Automatic noise limiting and gated AGC... standard.** Keep pulse-type interference to a minimum, maintain signal strength at a constant level.

**High resolution circuitry... standard.** Improves picture clarity. Adjustable video peaking lets you select the degree of sharpness.

**Adjustable tone control... standard.** Lets you vary the tone from the built-in dual cone 6x9" speaker from deep, rich bass to clean, crisp highs.

**Hi-fi sound output... standard.** Permits playing the audio from the "371" thru your hi-fi or stereo for better reproduction.

**Exclusive Heath owner-service capability built-in.** Heath color TV's are the only sets on the market that can be serviced by you... without special equipment or knowledge. The exclusive Heath manual, combined with the built-in dot generator and volt-ohm meter make service and adjustment easy... and save money.

**The GR-371 is the world's finest color TV.** Order yours now. **Kit GR-371**, 125 lbs... **\$579.95\***. Other solid-state color TV's in 227 & 295 sq. in. sizes from **\$489.95\***.

## 2 New Heathkit solid-state "Legato" 25-pedal Theatre Organ

The most versatile musical instrument ever created... here today in easy-to-assemble kit form, saving you hundreds of dollars over comparable organs. A truly professional instrument, designed exclusively for Heath by the famous Thomas Organ company.

**Exclusive Thomas Color-Glo key lights** show you correct notes & chords. Match the colors with your left hand, letters with your right. The unique Color-Glo keys and comprehensive Thomas organ course supplied will have you playing complete professional sounding songs in minutes, without musical knowledge.

**15 manual voices, 4 pedal voices...** any or all at the flip of a tab. SOLO: Diapason 16', Bass Clarinet 16', Trumpet 16', English Horn 8', Oboe 8', Violin 8', Tibia 16', Tibia 8', Tibia 4', Tibia 2'. ACCOMPANIMENT: Diapason 8', Saxophone 8', French Horn 8', Oboe Horn 8', Cello 8'. PEDAL: Diapason 16', Major Flute 8', Bass Clarinet 8', String Bass 8'.

**200 watts peak power** from two separate solid-state amplifiers... one for the Leslie system, one for the main system.

**"Stereo" sound.** 2-speed rotating Leslie to create the liquid tremolo beauty of the theatre organ... 2-12" speakers in the main system. Play some voices thru the Leslie, others thru the main system to create a lifelike "stereo" effect.

**Two 44-note keyboards...** both manuals tilt & overhang for easier playing. Accompaniment manual range 8'... F1 to C5; solo manual 16', 8', 4', 2'... F1 to C7.

**25-note heel & toe pedalboard...** exclusive Thomas Radial-Arc design, permits easy, tireless pedal playing. Range 16' & 8', C0 to C3.

**Other features include** selective repeat percussion for "strumming" effects; selective attack percussion for crisp piano or guitar sounds; Reverb for concert hall realism; variable vibrato and easy assembly with the famous Heathkit manual.

**Put a universe of sound in your home today...** order your new TO-101 now. **Kit TO-101**, 299 lbs... **\$1495\***. Playmate & Band Box accessories also available.

## 3 New Heathkit solid-state 14" portable Color TV

Console performance with portable convenience... that's the new GR-169. Heath engineers took the highly sophisticated circuitry of the new GR-371 above, modified it slightly to accommodate the smaller picture tube, eliminated the AFT feature, and put it in a handsome, compact cabinet. The result is a portable that performs better than any portable at any price... and better than most consoles as well. Features the unique Heath solid-state chassis for unexcelled performance and long-term reliability.

**Other features include** modular plug-in circuit boards for easier assembly, faster service. Solid-state 3-stage IF provides increased gain for improved picture quality. Factory assembled & aligned VHF tuner uses MOSFET design for greater sensitivity... delivers superior color pictures. Front panel secondary controls permit periodic minor adjustments without removing chassis from cabinet. Exclusive Heath self-service features built-in provide complete owner service capability... and you can do it without special knowledge or equipment.

**It all adds up...** to the new Heathkit GR-169... the world's finest portable (and one of the world's best consoles too!). Order yours today. **Kit GR-169**, 69 lbs... **\$349.95\***

## 4 New Heathkit solid-state 80-10 Meter Amateur Receiver

The world's best ham receiver. Tunes USB, LSB, AM, CW & RTTY, 80-10 M. 15 MHz WWV coverage. 100 & 25 kHz calibration. Dual gate MOSFET front end for greater dynamic range. Solid-state factory assembled & aligned Linear Master Oscillator for rock-solid tuning with 1 kHz readout. 1/4 uV sensitivity for 10 dB S+N/N. 2.1 kHz selectivity with built-in SSB crystal filter... optional AM & CW crystal filters available. Fast, easy assembly. Order your **SB-303** now. **Kit SB-303**, 21 lbs... **\$319.95\***

## 5 New Heathkit solid-state 15 MHz frequency counter

Now... frequency measurement at a price you can afford. Delivers stable, accurate counting from 1 Hz to over 15 MHz. All integrated circuitry for top performance, high reliability. Automatic trigger level for wide range input without adjustment. Five digit cold-cathode readout with Hz/kHz ranges and overrange indicators give 8-digit capability. Input Z 1 megohm shunted by less than 20 pF for low circuit loading. Order your new **IB-101** today. **Kit IB-101**, 7 lbs... **\$199.95\***

See these and 300 other Heathkit suggestions at one of the following Heathkit Electronic Centers:

### CALIFORNIA

Anaheim, 92805  
330 E. Ball Road  
El Cerrito, 94530  
6000 Potrero Avenue  
La Mesa, 92041  
8363 Center Drive  
Los Angeles, 90007  
2309 S. Flower St.  
Redwood City, 94063  
2001 Middlefield Rd.  
Woodland Hills, 91364  
22504 Ventura Blvd.

### COLORADO

Denver, 80212  
5940 W. 38th Ave.

### GEORGIA

Atlanta, 30305  
5285 Roswell Road

### ILLINOIS

Chicago, 60645  
3462-66 W. Devon Ave.  
Downers Grove, 60515  
224 Ogden Ave.

### MARYLAND

Rockville, 20852  
5542 Nicholson Lane

### MASSACHUSETTS

Wellesley, 02181  
165 Worcester St.

### MICHIGAN

Detroit, 48219  
18645 W. Eight Mile Rd.

### MINNESOTA

Hopkins, 55343  
101 Shady Oak Rd.

### MISSOURI

St. Louis, 63123  
9296 Gravois Ave.

### NEW JERSEY

Fair Lawn, 07410  
35-07 Broadway (Rte. 4)

### NEW YORK

Jericho, L.I., 11753  
15 Jericho Turnpike  
New York, 10036  
35 W. 45th Street

### OHIO

Cleveland, 44129  
5444 Pearl Rd.  
Woodlawn, 45215  
10133 Springfield Pike

### PENNSYLVANIA

Philadelphia, 19149  
6318 Roosevelt Blvd.

### Pittsburgh, 15235

3482 William Penn Hwy.

### TEXAS

Dallas, 75201  
2715 Ross Avenue  
Houston, 77027  
3705 Westheimer

### WASHINGTON

Seattle, 98121  
2221 Third Ave.

### WISCONSIN

Milwaukee, 53216  
5215 W. Fond du Lac

Retail Heathkit Electronic Center prices slightly higher to cover shipping, local stock, consultation and demonstration facilities. Local service also available whether you purchase locally or by factory mail order.



# Five New Heathkit® Solid-State Ideas

**1** 25" ultra-rectangular Color TV

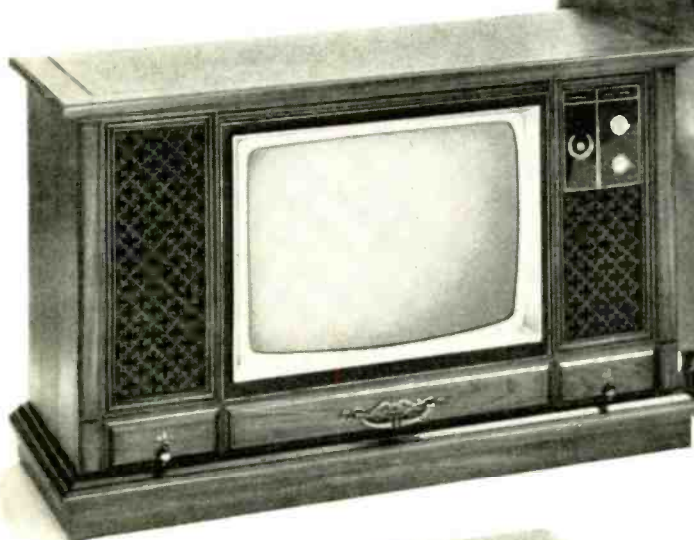

**2** 25-pedal theatre organ



**4** Amateur radio receiver



**3** 14" portable Color TV



**5** 15 MHz frequency counter



Another great idea:

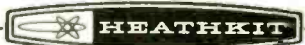

Send for your  
**FREE 1971  
Heathkit catalog  
today!**

HEATH COMPANY, Dept. 20-2 Benton Harbor, Michigan 49022	 a Schlumberger Company
<input type="checkbox"/> Enclosed is \$ _____, plus shipping.	
<input type="checkbox"/> Please send model (s) _____	
<input type="checkbox"/> Please send FREE Heathkit Catalog. <input type="checkbox"/> Please send Credit Application.	
Name _____	
Address _____	
City _____ State _____ Zip _____	
*Mail order prices; F.O.B. factory. Prices & specifications subject to change without notice.	
CL-400	

Circle 67 on reader service card

## Save Time on PC Board Repairs!



MODEL 100A

Melted solder  
disappears up  
hollow tip  
into tube

### The ENDECO Desoldering Iron Removes Soldered Components in seconds...without damage!

Endeco melts solder; removes last trace by vacuum. Leaves terminals and mounting holes clean. Resolders PC boards better than regular iron. One-hand operation. Temperature controlled for continuous use. Standard tip furnished, 5 other tip sizes. Pays for itself. \$20.65 net. Smaller size available. See your distributor or write:



ENTERPRISE  
DEVELOPMENT  
CORPORATION

5127 E. 65th • Indianapolis, Ind. 46220  
Circle 68 on reader service card

## NOW A ONE STOP SHOPPING CENTER FOR YOUR AUTO RADIO AND 8 TRACK STEREO PARTS. AT FACTORY DISCOUNTS

WE ARE AUTHORIZED PARTS  
DISTRIBUTORS FOR:

DELCO  
BENDIX  
MOTOROLA  
LEAR JET  
TENNA  
RANGER  
METRA  
AUTOMATIC  
ON GUARD  
CRAIG  
PANASONIC  
PHILIPS  
BELLE WOOD  
WARD  
QUICKMOUNT  
DEWEKO  
AC SPEEDO  
STEREO LOCK MOUNTS  
SPARKOMATIC

SEND YOUR ORDERS WITH  
PART NUMBERS TO

## Laran Electronics, Inc.

3768 Boston Road  
Dept. 200 Bronx, N.Y. 10469  
OR SEND MODEL, MAKE AND  
DESCRIPTION OF PART WANTED

Circle 69 on reader service card

### IN THE SHOP (continued from page 26)

signal here, but get no output, we read the dc voltages around the chip-socket. To repeat, all of the dc voltages found here are developed inside the chip, except for the 24-volt supply. The three color output terminals, 7, 8 and 9, should read +15.2 volts. Terminals 2 and 3 should read +3.2 volts, 4 and 5 should read +5.8 volts. Pin 1 is ground.

If any of these voltages are off limits, for example, 7 and 8 normal, 9 low or high; check all external components connected to the faulty terminal. An open load resistor, leaky coupling capacitor, etc could be the cause of this type of trouble. One good quick-check for possible external troubles is simply pulling the chip, which is mounted on a standard 9-pin tube base. If the rest of the things are ok, there should be zero dc voltage on all pins except the 24-volt supply, which should rise to about 26 volts or so.

Another good check for possible chip trouble is to read the dc current drawn. In this one, normal current is 22 mA  $\pm$  about 1.0 mA. Current a good deal greater than this would indicate a short, quite a bit less than this some kind of open circuit inside the chip.

Leaky coupling capacitors can be checked by lifting one end and rechecking the dc voltage on the chip-socket. For example, the two .05  $\mu$ F's which feed in the 1/Q CW signal from the transmission line to the oscillator. If either of these were shorted or leaking, the dc voltage would drop because of the low resistance to ground of the transmission line chokes, etc. Resistors can be checked with an ohmmeter.

You might think that these things run cool. They don't. The chip case will warm up in operation, to a temperature somewhere around 100°F, or slightly warm to a fingertip. If there is an internal short, it will probably get hot enough to make you withdraw the fingertip pretty fast. If the chip is "stone-cold" after the set has been running for say 5 minutes, it is quite apt to be open (or the 24-volt supply missing; check that first. This can be done "from the top", by taking a reading on pin 6. All leads of the 221-37 or 221-39 IC's are exposed, since it is mounted on a wafer base. Voltage readings and replacement can be made without pulling the chassis.

All in all, though these things are a novelty to most of us, I don't think they're going to cause us any more trouble than any other type of component. With a few logical tests and diagnoses, we can spot and clear up any kind of trouble originating in the IC's or in the external circuitry. **R-E**

### DID YOU MISS?

Learn how to replace unknown transistors in electronic equipment. Service Editor Jack Darr tells how it can be done on page 33. Next month he concludes this article with a series of case histories demonstrating his technique.

# Service Clinic

By JACK DARR  
SERVICE EDITOR

This column is for your service problems—TV, radio, audio or general and industrial electronics. We answer all questions individually by mail, free of charge, and the more interesting ones will be printed here.

If you're really stuck, write us. We'll do our best to help you. Don't forget to enclose a stamped, self-addressed envelope. Write: Service Editor, Radio-Electronics, 200 Park Ave. South, New York 10003.

### SCREWBALL REACTIONS

#### RCA KCS-136

I've an RCA KCS-136 chassis that's got some of the screwiest reactions I've ever seen! It's got a pale picture, lousy sync, and the agc voltage is much too high, negative. This is not bad. But, when I pulled the 6GX6 audio detector tube (I forget why, but I did.), the picture GOT BETTER! Cleared up a lot! Riddle me that one!—R. F., Boston, Mass.

Well the Crystal Ball nearly popped its circuit-breaker on this one, but I found it in the file! It happened to me some time ago, with almost all the same reactions.

Your major trouble is agc, as you thought. So far, so good. The "picture gets better when the sound

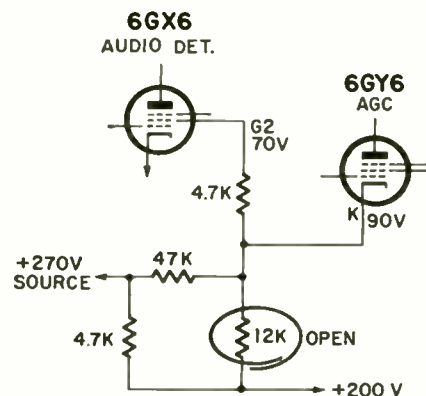

tube is pulled" symptom is due to the simple (after you find it!) fact that the agc tube is supplied from a little voltage-divider between the +200 V and +270 V lines. So is the 6GX6 audio detector! Taking the screen-grid load off the voltage-divider changed the voltage. You'll find that the 12,000-ohm resistor in the divider is open, I believe.

(continued on page 84)



# COMING NEXT MONTH

MARCH 1971

## STEREO SPECTACULAR MONTH

### ■ Quad Stereo — What's Happening

Up-to-the-minute report on the latest developments in 4-channel stereo. Find out what's going on with 4-channel tape, records, and broadcasting.

### ■ 6 Ways To Improve Your Stereo System

Contributing Editor Matt Mandl details six simple improvements you can make to insure getting the best out of your music system.

### ■ Transformerless Stereo Adapter

Turn any FM radio into a stereo-FM receiver by adding on this solid-state circuit. Novel design lets you build it without using any inductors. Printed circuit simplifies construction.

### ■ Cassette Recorder Circuits

Step-by-step programmed article presents and explains the electronic circuits used in today's cassette recorder.

### ■ Fluorescent Light Strobe

Simple project shows how to turn a single-tube fluorescent light fixture into a pulsating, rhythmic light that really jumps.

PLUS . . .

Designing Solid-State Amplifiers  
All About the Laser  
Technical Topics  
Jack Darr's Service Clinic  
Home Appliance Electronics

# CB Troubleshooter's Casebook

Compiled by  
Andrew J. Mueller\*

Case: Transmit is weak. Receive is normal.  
Common to: Johnson 242-102

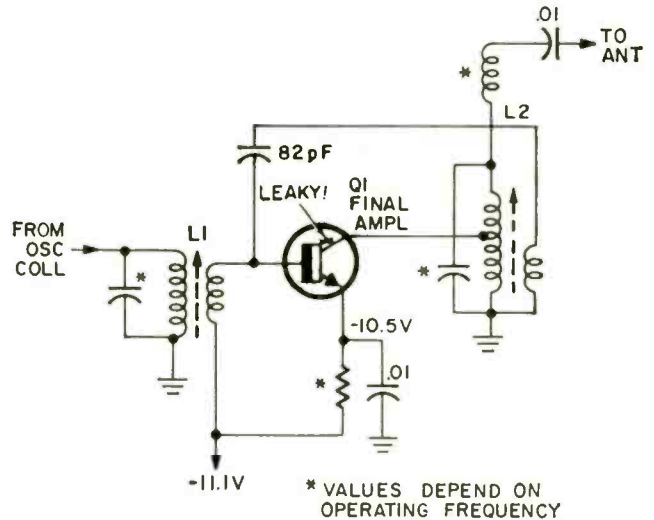

**Remedy:** Replace Q1.  
**Reasoning:** Q1 is the transmitter final power amplifier. It is very leaky from the base to the collector. Replacing Q1 and realigning L1 and L2 will restore transmitting to normal. **R-E**

\*Service Manager, Tel-Air Communications, Inc., Pewaukee, Wis.

LISTEN TO: **INSTANT!**  
**POLICE, FIRE,  
& WEATHER REPORTS!**  
Perfect for  
Industrial, Commercial, Utility  
and Government Use  
**SONAR SENTRY  
VHF MONITOR RECEIVERS**  
ADJUSTABLE SQUELCH

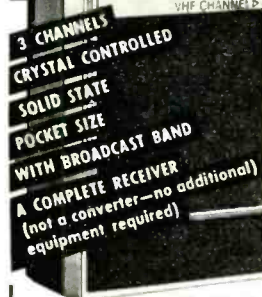

Designed and engineered for simplicity of operation, compact enough to fit a shirt pocket yet powerful enough to deliver a clear clean signal — it's dependable • Operates on three crystal controlled VHF channels and tuneable broadcast band • Adjustable squelch • Completely solid state for long life use • Visible battery indicator to show battery condition at all times • Built in antenna • 5 7/8" H x 2 1/2" W x 1 1/16" D. Wt. 11 oz.

**\$4995**

With Battery & Earphone  
less Crystals  
Crystals \$5.00 ea.

MODELS  
**FR-103-SA**  
150-175 MHz  
**FR-106-SA**  
(IN 4 FREQUENCIES)  
A-30-33MHz—B-33-38MHz  
C-38-44MHz—D-44-50MHz

**SONAR RADIO CORPORATION**  
73 Wortman Ave., Brooklyn, N.Y. 11207

Please send me information on VHF Monitor Receivers  
Dept. 246

Name .....  
Address .....  
City..... State..... Zip.....

Circle 70 on reader service card

# Who Needs a Tuner Wash?

Use **QUIETROLE** Mark II Spray Pack

The product that cleans and lubricates better than any product you can buy and has been used for more years than any product of its kind.

The Choice of "Better Servicemen" Everywhere



manufactured by **QUIETROLE COMPANY**  
Spartanburg, South Carolina

Circle 71 on reader service card

### SERVICE CLINIC (continued from page 82)

This changes the age tube cathode voltage, and of course, upsets the dc voltages around that whole stage. Isn't it remarkable how simple these are, afterward?

### 'VERTICAL BARS' IN COLOR, RCA CTC 28

In an RCA CTC 28, there are about seven vertical bars on the screen, about 3/4 inch wide. At the left side of the screen, the red seems to be missing. On a weak signal, this is worse. I've checked out the antenna, all of the horizontal section tubes, etc. with no luck. Swapped the 6GU7 tubes; no help. Can't see anything that could cause a 60-Hz pickup.—K. W., Fullerton, Calif.

This isn't a 60-Hz problem; that makes horizontal bars. The basis of this trouble is some sort of stray pickup of the original horizontal-blanking waveform. In this, the spike does the blanking, and the ringing along the baseline must be completely clipped off! I believe that these ringing-waves are the cause of this trouble.

Check the waveforms on the horizontal blanker, the "1-2-3" triode of the 6GU7 (other part is the G-Y amplifier). Also, check the keying pulse on the burst amplifier grid, which also goes to the 6KE8 color

bandpass amplifier grid. If the ringing is too great on this waveform, it can override the clamp action of bypass capacitors, etc., and get into the color and/or burst amplifiers. There are sev-

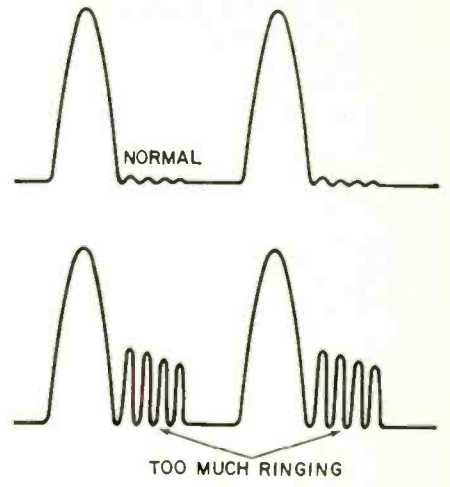

eral bypass capacitors which could open, and allow this to happen. Try shunting each of these with another capacitor. Since they will all cause the same trouble, we can't pinpoint it without making actual tests. **R-E**

**NEXT MONTH**  
Want to build an FM multiplex adapter that doesn't use any inductors? See the article by Len D'Airo in the March, 1971 Stereo issue.

# UNBEATABLE BARGAIN BUYS

FREE \$1 BUY WITH EVERY 10 YOU ORDER Only applies to "S1" Buys FREE GIFT WITH EVERY ORDER

- KNOB SPECIAL**
- 100 — ASSORTED RADIO KNOBS All standard types ... \$1
  - 50 — TV KNOBS — POPULAR TYPES For most sets ... \$1
  - 25 — VERTICAL LINEARITY KNOBS Long shank ... Front mount ... miniature assortment ... \$1
  - 30 — VERTICAL LINEARITY KNOBS Side mount ... Standard sizes ... \$1
  - 25 — KNURLED RADIO KNOBS Hard to get ... Best selection ... \$1
  - 25 ASSORTED CLOCK-RADIO KNOBS Best assortment, Most popular types ... \$1
- ANY 6 KITS FOR \$5
- STEREO HEADPHONES Hi-Fi Quality Complete with Stereo plug ... \$5.95
  - 50 — TUBE CARTONS (colored) assorted sizes for Popular Tubes ... \$1
  - 4 — 36" HI-FI CABLES RCA Molded Phone plug at one end stripped and tinned leads on other end ... \$1
  - 3' JUMPER CABLES Male RCA Type Plug on Both Ends, 2 For ... \$1.19
  - 50 — ASST. TERMINAL STRIPS all types, 1-lug to 6-lug ... \$1
  - 2—G.E. PIECES OF EQUIPMENT stacked with over 200 useful parts ... \$1
  - \$20 — SHURE M7D DIAMOND NEEDLE exact replacement ... \$3
  - SHURE M44 SERIES DIAMOND NEEDLE exact Replacement ... \$4.69
  - PICKERING V-15 DIAMOND NEEDLE exact replacement ... \$4.69

- TRANSISTOR RADIO *asst type* good, bad, broken, as-is, potluck ... \$1.50
- TAPE RECORDER—assorted types good, bad, broken, as-is, potluck ... \$4
- 300 — ASST. 1/2 W RESISTORS Top Brand, Short Leads. Excellent Selection ... \$1
- 100—ASST 1/4 WATT RESISTORS stand, choice ohmages, some in 5% ... \$1
- 100—ASST 1/2 WATT RESISTORS stand, choice ohmages, some in 5% ... \$1
- 70 — ASST 1 WATT RESISTORS stand, choice ohmages, some in 5% ... \$1
- 35 — ASST 2 WATT RESISTORS stand, choice ohmages, some in 5% ... \$1
- 50 — PRECISION RESISTORS asst. list-price \$50 less 98% ... \$1
- 20 — ASSORTED WIREWOUND RESISTORS, 5, 10, 20 watt ... \$1
- 4 — TOGGLE SWITCHES SPST, SPDT, DPST, DPDT ... \$1
- 10—ASSORTED SLIDE SWITCHES SPST, SPDT, DPDT, etc. ... \$1
- COLOR POWER TRANSFORMER — Good for most sets 2BR150 List Price—\$36.75 ... \$6.95
- 6 — TRANSISTOR RADIO EAR-PIECES wires complete with plug ... \$1
- 100 — FINEST NYLON DIAL CORD best size, .028 gauge ... \$1
- 10 — SETS PHONO PLUGS & PIN JACKS RCA type ... \$1
- 3—PRINTED CIRCUIT IF TRANSFORMERS 4-lug, 456 KC ... \$1
- 25 — 3900-OHM-7w RESISTOR 10% Corning glass ... \$1
- 20 — 47-600V CONDENSERS White Ceramic C.D.—American ... \$1

- 12—MINIATURE ELECTROLYTIC CONDENSERS For Transistor & miniature work ... \$1
- 10 — MINIATURE 456KC IF TRANSFORMERS Exceptional value —PC—1/2" x 1/2" ... \$1
- HEAVY DUTY COLOR FOCUS RECTIFIER 14,000 PIV @ 1 ma ... \$1
- 50 — OIL IMPREGNATED TUBULAR CAPACITORS Percelein, Axial Leads—Most popular values ... \$3.25
- COLOR-TV RECTIFIER — Used in most color sets—6500 kv ... 3 for \$1.95
- 15 — ASST. ROTARY SWITCHES all popular types \$20 value ... \$1
- 15 — G.E. #NE-2 TUBES Neon Glow Lamp for 101 uses ... \$1
- 150' — BUSS WIRE #20 tinned for hookups, special circuits, etc. ... \$1
- 50 — .0033 DISC CERAMIC CAPACITORS C.R.L. ... \$1
- 3—ELECTROLYTIC CONDENSERS most popular number 50/30—150v ... \$1
- 7 — TV ELECTROLYTIC CONDENSERS desirable types ... \$1
- 5 — 6' LINE CORDS #18 Stranded Copper Wire ... \$1
- MOTOROLA PWR TRANSFORM 110v, CT 150/150v, 6.3v ... \$1
- 25 — #130 WESTINGHOUSE PILOT BULBS 5000 hours. Same as #47 ... \$1
- 25—WESTINGHOUSE PILOT BULBS Your choice of #241, #154, #PR-28 ... \$1
- 3—ELECTROLYTIC CONDENSERS C.D. 500 mfd—200 volts ... \$1

**SARKES TARZIAN TUNER**  
41mc

Latest Compact Model good for all 41 mc TV's. BRAND NEW—

Best TUNER "SARKES TARZIAN" ever made—last word for stability, definition & smoothness of operation. An opportunity—to improve and bring your TV Receiver up-to-date. **\$7.95**

COMPLETE with Tubes

- TV TUNER — asst. all new standard makes. Less tubes ... \$1
- WESTINGHOUSE STANDARD TUNER Series Type ... \$4
- MATCHED PAIRS TRANSISTORS NPN & PNP (2N4252-2N2904) (2N2222-2N2907) Each set ... \$1
- UHF TUNER — TRANSISTOR TYPE Used in all TV sets ... \$3.95
- 50 — ASSORTED PRINTED CIR. CUIT SOCKETS best types ... \$1
- ASTATIC #13T STEREO CAR. TRIDGE plug in. power point ... \$3.78
- RONETTE STEREO CARTRIDGE latest dual sapphire flipover type ... \$2

**IMMEDIATE DELIVERY** . . . Scientific light packing for safe delivery at minimum cost. **HANDY WAY TO ORDER:** Pencil mark or write amounts wanted in each box, place letter F in box for Free \$1 BUY. Enclose with check or money order, add extra for shipping. Tear sheets will be returned as packing slips in your order, plus lists of new offers. **Minimum Order \$3.00**

Name ..... Cost of goods  
Address ..... Shipping  
..... estimated  
..... TOTAL

Please specify refund on shipping overpayment desired:  CHECK  POSTAGE STAMPS  MERCHANDISE (our choice) with advantage to customer

**BROOKS RADIO & TV CORP., 487 Columbus Ave., New York, N. Y. 10024** 212-874 5600 TELEPHONE



# TRY THIS ONE

## SIMPLE AUDIBLE ALARM

An excellent alarm, producing a tone similar to that from a Sonalert, can be made from a discarded transistor radio if its audio system is still operable. Many inexpensive radios have been discarded because of troubles in the rf or i.f. circuits. These can be pressed into service as signalling devices since only the audio components and speaker are used.

Merely solder one end of a .002- $\mu$ F to the center terminal of the vol-

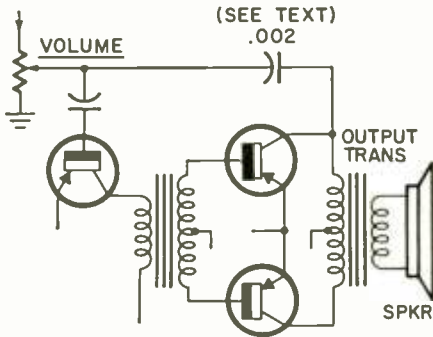

makes the circuit sound off. No damage will result from trying various take-off points. Any tone from a low growl up to several kHz can be obtained by using different capacitor values.

To use the alarm, arrange to have one side of the battery circuit open until it is desired to have a signal. For example, a burglar alarm can be made by using a fine thread to hold two spring contacts apart; then if the string is broken the contacts are closed to start the alarm. The alarm is battery operated and cannot be defeated by cutting off the ac supply to the house. The device uses very little current when operating and none at all when idle. Insert a telegraph key in series with the battery and you will have a neat little code practice oscillator.—George Garvin

## RENEWING RELAY CONTACTS

When silver contacts on a relay wear and require immediate renewal, you can either renew them or make new ones by using a propane torch to melt silver solder on them or atop suitable screws, then file them down to the required size.—H. Josephs R-E

ume control and the other to the collector of one of the output transistors. If you have trouble locating an output collector, just try various points on the PC board until you find one that

# NEW MONITOR RECEIVER goes anywhere!



- MOBILE with built-in DC supply
- BASE with AC supply in convenient desk-top stand
- PORTABLE with rechargeable power pack complete with handle and antenna

VHF FM models cover 148-174 MHz with 5 channels. Professional features include crystal filter and true noise-operated squelch.



You're going to hear more from...



**JOHNSON**

Waseca, Minnesota 56093  
Circle 72 on reader service card

## SHANNON MYLAR RECORDING TAPE

2 1/2" - 225' .. \$ .17	7" - 2400' .. \$1.79
3" - 225' .. .19	7" - 3600' .. 2.95
3" - 300' .. .27	CASSETTE 60 minutes .89
3 1/4" - 600' .. .58	CASSETTE 90 minutes 1.54
5" - 600' .. .62	CASSETTE 120 minutes 1.97
5" - 900' .. .80	
5" - 1200' .. .97	2 1/2" TAPE REEL .. .04
5" - 1800' .. 1.49	3" TAPE REEL .. .05
7" - 1200' .. .77	3 1/4" TAPE REEL .. .06
7" - 1800' .. 1.12	5" TAPE REEL .. .12
	7" TAPE REEL .. .14

CANADIANS: Ordering is easy — we do the paperwork — try a small order



## IBM COMPUTER SECTIONS

8 assorted Units we sell for \$1 are loaded with over 150 valuable parts. Incl. — Transistors, Condensers, Resistors, Heat Sinks, Diodes, Etc.

8 for \$1  
100 for \$10

## WESTINGHOUSE ALL TRANSISTOR HOME/OFFICE MESSAGE CENTER

Leaves messages for other for replay . . . Built in speaker/microphone for talk-into convenience . . . Records up to 3 minutes of messages . . . Illuminated signal shows when a message is waiting. Control adjusts playback volume without affecting recording volume . . . Capstan Drive: BRAND NEW SOLD AS IS \$7.95

- 4 - TV ALIGNMENT TOOLS most useful assortment #1 .. \$1
- 4 - TV ALIGNMENT TOOLS For Color TV #2 .. \$1.49
- 6 - TV COLOR ALIGNMENT TOOLS Most popular type .. \$2.79
- 5 - PNP TRANSISTOR general purpose, TO-5 case .. \$1
- 5 - NPN TRANSISTORS general purpose, TO-5 case .. \$1
- TV TWIN LEAD-IN 300 ohm 500' — \$7 100' — \$1.50 50' — \$2
- CO-AX CABLE RG59U grey or black 250' — \$9 100' — \$3.69 50' — \$1
- 50 - ASSORTED TRANSISTORS big factory scoop—sold as-is .. \$1
- 0 TO 200 MICRO AMP MINIATURE METER 1 1/2 x 1 1/2" Wt. 3 Oz. Excellent 8 meter .. \$1
- 10 - STANDARD TRANSISTORS NPN & PNP 2N404, 2N414, etc. .. \$1
- 10-ASSORTED DIODE CRYSTALS 1N34, 1N48, 1N60, 1N64, etc. .. \$1
- 3 - TOP BRAND SILICON RECTIFIERS 1 amp, 1000 PIV .. \$1
- 20 - ASST. PILOT LIGHTS #44, 46, 47, 51, etc. .. \$1
- 50 - ASSORTED #3AG FUSES popular ampere ratings .. \$1
- 4-50' HANKS HOOK-UP WIRE assorted colors .. \$1
- 100'-SPOOL SPEAKER WIRE 2 cond, mini zip, clear, 101 uses .. \$1.50
- 5 - I.F. COIL TRANSFORMERS 450-ke for Transistor Radios .. \$1
- 5 - AUDIO OUTPUT TRANS-FORM Sub-min for Trans Radios .. \$1

- WESTINGHOUSE FM TUNER (12DTS Tube) .. \$2.99
- WESTINGHOUSE FM TUNER #476-V-015D01 Transistor .. \$3.99
- 300 - ASSORTED HEX NUTS 2/56, 4/40, 5/40, 6/32, 8/32 .. \$1
- 250 - ASST. SOLDERING LUGS best types and sizes .. \$1
- 250 - ASST. WOOD SCREWS finest popular selection .. \$1
- 250 - ASST. SELF TAPPING SCREWS #6, #8, etc. .. \$1
- 150 - ASST. 6/32 SCREWS and 150 6/32 HEX NUTS .. \$1
- 150 - ASST. 8/32 SCREWS and 150-8/32 HEX NUTS .. \$1
- 150 - ASST. 2/56 SCREWS and 150-2/56 HEX NUTS .. \$1
- 150 - ASST. 4/40 SCREWS and 150-4/40 HEX NUTS .. \$1
- 150 - ASST. 5/40 SCREWS and 150-5/40 HEX NUTS .. \$1
- 500 - ASSORTED RIVETS most useful selected sizes .. \$1
- 500 - ASSORTED WASHERS most useful selected sizes .. \$1
- 100 - ASST. RUBBER BUMPERS for cabinet bottoms & other uses .. \$1
- 100-ASSORTED RUBBER GROMMETS best sizes .. \$1

## MARKET SCOOP COLUMN

- STANDARD TUNER - TRANSISTOR (GUIDED GRID) 4 Channel closed circuit .. \$1
- AF POWER AMPLIFIER TRANSISTOR GE-12, RCA-SK3021, HEP-240 .. \$1.95
- GE-2, RCA-SK3009, HEP-230 Replacement .. \$1.39
- 5 ASSORTED GLOBAR VARI-SISTOR Popular replacements for most COLOR TV .. \$1
- 12" X UNIVERSAL SPEAKER. Top Quality .. Large Magnet .. \$4
- 10" PHILCO SPEAKER Top Quality .. Large Magnet .. \$2.69
- 8" UNIVERSAL SPEAKER Large Magnet—Special Buy .. \$2.49
- UTAH 8"—HEAVY DUTY 10 OZ. SPEAKER Ceramic Type—Special Buy .. \$3.69
- 6"—ECONOMY SPEAKER Top quality 2 1/2 Mag. .. \$2.94
- 5" UNIVERSAL TWEETER 1.29 1 Oz. Magnet .. \$1.29
- UNIVERSAL 4" PM SPEAKER With 5016 Output Transformer .. \$1
- 2 1/2" x 4" SPEAKER Special Buy .. 69¢
- 3 1/2" - ROUND SPEAKER Special Buy .. 59¢
- 4" x 6" "QUAM" 16 OHM SPEAKER Large magnet .. Special BUY .. \$1.79
- 75-68K 1/2 WATT RESIS-TORS .. \$1
- 75-10 Meg 1/2 WATT RESIS-TORS .. \$1

## RCA 110° FLYBACK TRANSFORMER

- We scooped the Market Latest type — standard for all 110° TV's RCA's design of large Coil produces 18KV—assuring adequate with Incl Schematic Diagram application for any TV List price \$13.90 Your price .. \$3 10% off in lots of 3
- 75-3.3 Meg 1/2 WATT RESIS-TORS .. \$1
- 110° TV DEFLECTION YOKE for all types TV's Incl schematic .. \$3
- "COMBINATION SPECIAL" RCA 110° FLYBACK plus 110° DEFLECTION YOKE .. \$5
- 90° FLYBACK TRANSFORMER for all type TV's Incl schematic .. \$2
- 90° TV DEFLECTION YOKE for all type TV's Incl schematic .. \$2
- 70° FLYBACK TRANSFORMER for all type TV's Incl schematic .. \$2
- 70° TV DEFLECTION YOKE for all type TV's Incl schematic .. \$2
- 2 - TV CIRCUIT BREAKERS Rated 4.2 TO 5.0 AMPS, etc. .. \$1-19
- 70° COLOR YOKE For all round color CRT's .. \$12-93
- 90° COLOR YOKE For all Rectangular 19 to 25" Color CRT's .. \$10-93

Circle 73 on reader service card

# NOTEWORTHY CIRCUIT

## SCR TOOL-SPEED CONTROL

This SCR control unit (see diagram) effectively slows down the speed of an electric drill, sander or other item around the home workshop, that has a universal, commutator-brush-type ac/dc motor. It's also handy for cutting down the input voltage to a transformer; for dimming incandescent lamps, etc.

The SCR should be rated to

carry the maximum current you want to control. You can use the G-E C15B or up to 3 amps and the C37B for up to 8 amps. Be sure to use an adequate heat sink for the SCR. It dissipates quite a bit of heat when the circuit is adjusted for dim lights or slow-speed operation.

The value of R1 may be altered if the minimum speed of the tool is too slow. Try values from 22 to 68

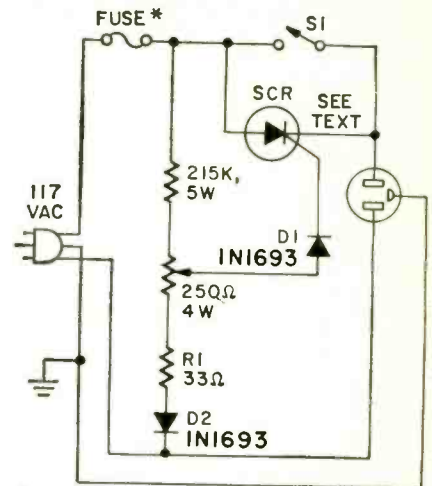

\* TO MATCH SCR AND CIRCUIT LOAD CURRENT

ohms. A small 75-ohm pot could also be used for this resistor. Switch S1 bypasses control unit.—Bob Lange R-E

**WHAT DO YOU DO WITH A LASER?**  
If you don't know, turn back to page 43 and find out. In this continuing series of articles on lasers you'll find a complete section on today's applications for lasers.

## LIGHT ACTIVATED SCRs

STOCK	PRV	PRICE
B4116	60	1.00
B4117	100	1.95
B4118	200	2.50
B4119	300	3.50

## HONEYWELL COMPUTER BOARDS

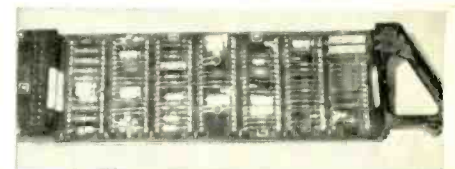

Honeywell Computer boards, 4½" x 12". Transistors, diodes, zeners, capacitors, precision resistors, heat sinks, trimmers etc. 2 Different boards \$1.00. Stock No. B9082.

Stock No. B9040

Honeywell Boards 5½" x 6". Loaded with late no. transistors, diodes, resistors and capacitors. 2 different boards \$1.25.

### COMPUTER GRADE CAPACITORS

B2040 Sangamo or Pyramid 4¼" x 1¾"  
4000 MFD 50V ..... 65 5/3.00

**\$1.00 FREE WITH \$10.00 ORDER**

**MINIMUM ORDER 3.00**

Lots of other items—send for free flier; all merchandise fully guaranteed. Please include postage; excess will be refunded.

**DELTA ELECTRONICS CO.**  
BOX 1, LYNN, MASSACHUSETTS 01903

Circle 79 on reader service card

RADIO-ELECTRONICS

# FREE!

## Lafayette's 1971 Golden Jubilee Catalog



## 50th LRE anniversary

## 468 PAGES

Your 1st Guide  
To Everything  
in Electronics

- Stereo/Hi-Fi Components • Musical Instruments and Amplifiers
- Photography Equipment • Ham and CB Gear • Public Address Systems
- Tools and Test Equipment • Educational and Optical Equipment
- Black and White/Color Televisions • Police and Fire Monitor Receivers • Books and Parts

Plus Thousands of Additional Items



Send For Your Free 1971 Lafayette Catalog Today!

LAFAYETTE Radio ELECTRONICS Dept. 17021  
P. O. Box 10, Syosset, L. I., N. Y. 11791

Mail This  
Coupon Today  
For Your  
1971 Catalog  
No. 710

Send Me the Free Lafayette Golden Jubilee 1971 Catalog 710

Name ..... 17021

Address .....

City .....

State ..... Zip .....

(Please include your zip code)

Circle 74 on reader service card



# R-E's Logic Laboratory

HERE IS A COMPLETE LIST OF ALL PARTS required to assemble R-E's Logic Laboratory (December 1970 and January 1971). As well as individual parts lists, you will find a separate list of suppliers for some of the more exotic elements. At the end of this section you will find a listing of various groups of parts and printed-circuit boards that can be used to assemble the lab.

In the months to come we will present an assortment of experiments that can be performed with the completed unit. If there are any particular arrangements you would like to see, let us know and we'll pass them on to the author.

## SUPPLIERS ADDRESSES SPECTRA-STRIP CORPORATION

P.O. Box 415  
Garden Grove, California 92642  
Part Number SS-3026-7B (30 conductors, #26 AWG, 7 strands, type B insulation, Spectra-Strip flat ribbon cable).

## MURA CORPORATION

355 Great Neck Road  
Great Neck, N.Y. 11021  
Model L-6/50 lamps with round lens caps

## CALECTRO, GC Electronics

Division of Hydrometals, Inc.  
400 South Wyman Street  
Rockford, Illinois 61101  
Part #E2-118 miniature DPDT toggle switches

## MARK EYELET & STAMPING INC.

Wakelee Road, Route 69  
Wolcott, Connecticut 06716  
Mark Part Number M-843F eyelets, tin plated

## SCHRY-WAY CASES

2211 E. Walnut Street  
Pasadena, California 91107  
Case Model L1P-12-9-4-3/1 with split hinges on left side, narrow dimension horizontal, catch on right side looking at front, handle centered top (12") four rubber feet on bottom of large section. Include four corner mounting blocks.

## CASE PARTS LIST

- 1 12.75 x 9.75 x 4.5 inch hardwood case.
- 1 Type 7486 3-wire male base for power.
- 1 Type 7484 3-wire female connector and a 3-wire line cord. Assembled, these will make the 120-volt ac power cord. Glue, paint, sandpaper and similar material to finish as desired.
- 1 Calectro Catalog #N4-057 power supply (a 9-volt battery could be used here)
- 1 6.3-volt, 1-2A transformer (Allied #54D2030 or equivalent)
- 1 12.6-volt, 1-2A transformer (Allied #54D4136 or equivalent)
- 1 Fuse holder, Littelfuse #357001 (Allied #57D3009 or equivalent)
- 2 Terminal strips, H.H. Smith Type 879

## LOGIC PANEL PARTS LIST

- 1 Printed circuit card\*
- 338 Eyelets (Mark Eyelet and Stamping #M-843F)
- 2 TI SN7400N or equivalent
- 2 TI SN7410N or equivalent
- 2 TI SN7420N or equivalent
- 2 TI SN7450N or equivalent
- 4 TI SN7473N or equivalent
- 5 15- $\mu$ F, 20-volt tantalum capacitors

- 8 "L" brackets (Calectro Catalog #J4-642) Wire and 4-40 hardware as required
- \*see price list

## DISPLAY PANEL PARTS LIST

- 1 Panel assembly\*
- 1 Potentiometer, 500,000 ohms Mallory type MLO N55L, with 1/4 inch bushing. Allied Part #46D1143
- 1 Knob for the potentiometer, Mallory Type 1910K, Allied Part #46D1146
- 8 Type L-6/50 Muralite lamps with lens caps—3 red, 3 green and 2 yellow
- 10 Dpdt switches, Calectro Catalog #E2-118
- 2 Pushbutton switches with Form C contacts (single pole, double throw), and 1/4" bushing

\*see price list

## CLOCK-LAMP DRIVER PARTS LIST

- 1 Circuit card\*
- 1 220-ohm resistor, 1/4 watt (R2)
- 1 47,000-ohm resistor, 1/4 watt (R3)
- 1 100-ohm resistor, 1/4 watt (R4)
- 8 3,300-ohm resistors, 1/4 watt (R01 thru R07)
- 1 .25- $\mu$ F, Mylar capacitor (C1)
- 1 .001- $\mu$ F ceramic capacitor (C2)
- 1 15- $\mu$ F, 20-volt tantalum capacitor (C3)
- 16 1N914 diodes (D01 thru D71) (D02 thru D72) (Q0 thru Q7)
- 8 2N3705 transistors (Q8)
- 1 2N4870 Unijunction transistor
- 2 SP380A Signetics IC's
- 1 SP322B Signetics IC

\*see price list

## RECTIFIER-REGULATOR PARTS LIST

- 1 Circuit card
- 2 Motorola MDA 942A-1 Bridge rectifier assemblies
- 3 500- $\mu$ F, 25-volt electrolytic capacitors Sprague Type 39D507G025HE4
- 1 1N5337B Zener diode, 4.7-volt, 5-watt, 5% (D9)
- 1 1N5338B Zener diode, 5.1-volt, 5-watt, 5% (D10)
- 1 2N4231 2A 35-watt, npn power transistor
- 1 Thermalloy Model 6166B transistor cooler assembly
- 1 0.75-ohm resistor, 2-watt, 10%, BWH Type (R1)
- 1 3.5-ohm resistor, 2-watt, 10%, BWH Type (R2)
- 2 20-ohm resistor, 2-watt, 10%, BWH Type (R5 and R6)
- 2 220-ohm resistor, 2-watt, 10%, BWH Type (R3 and R4)

## LOGIC LAB PARTS

Parts for the logic laboratory are available from Southwest Technical Products Corp., 219 Rhapsody, San Antonio, Texas, 78216. The following items are available:

- ✓ Rectifier-Regulator Board . . . . . \$2.20
- Kit of parts plus board . . . . . \$17.50
- ✓ Lamp-clock Driver Board . . . . . \$2.10
- ✓ Kit of parts plus board . . . . . \$20.75
- Lamp and Switch Panel with associated parts . . . . . \$20.00
- ✓ Main Logic Panel Board . . . . . \$8.50
- Kit of parts plus board . . . . . \$36.40

R-E

## IMPOSSIBLE?... BARGAINS IN SURPLUS ELECTRONICS (AND OPTICS)



### GOVERNMENT SURPLUS GEIGER COUNTER

"USAF" radiation detectors are in like new condition, with instructions. Shirt pocket size, in gray plastic case. Requires one each 1.35 V and 5.4 volt mercury batteries, cost about \$3.00. Will operate fine from less expensive penlite batteries. Quantity limited  
ASAFGC . . . \$7.50 ppd.



### PUSH BUTTON SWITCHES

These high grade moulded bakelite push button switches were made to be used as a computer entry device. Uses are limited only by your imagination. Consists of seven sections, six double pole double throw and one four pole double throw. May be cut apart to make seven independent switches. Alternate action, similar to switches on professional audio equipment.  
PBS-1 . . . . . \$1.25 each

### SPECIAL! INTEGRATED CIRCUIT VOLTAGE REGULATOR

Latest type, Motorola MC1460G, RCA 3055 or equivalent. Range 3 to 30 volts at 200 MA, 4 amperes with external transistor. Foldback current limiting makes it short circuit proof. Complete with circuit diagrams and data sheets. MFGS price over \$6.00.  
Our price . . . . . \$2.00 each



### POWER SUPPLY KIT

We have taken a select group of surplus components, and put together this bargain kit. The kit includes all components required to make a power supply as shown capable of supplying 24 volts at 2 amps, 12 volts at 4 amps or 6 volts

at 8 amps. You couldn't build or buy this same supply at 4 times our low price of \$13.50. For an additional \$8.00, we supply the P. C. board and components to build an integrated circuit regulator for this supply, using a silicon power transistor and the I. C. regulator described elsewhere in this ad.

- Power Supply Kit, Unregulated . . . . . \$13.50
- Power Supply Kit, Regulated . . . . . \$21.50

Charges Welcome \$10.00 min  
Bank Americard—Master Charge

- TI T1S43 Unijunction Xsistor . . . . . 2/\$1.00
- TI 2N3819 FET Xsistor . . . . . 2/\$1.00
- 1N3821A (3.3 volts) 1 watt, 1N3822A (3.6 volts) 1 watt, 1N429 reference or 12 volt 3 watt zener.  
Your choice . . . . . 3/\$1.00
- Socket for 14 pin DIP integrated circuit . . . 3/\$1.00
- Integrated Circuits, TTL flat pak, new original packages . . . 5400 quad 4 input, 5410 triple 3 input, 5420 dual 4 input, 5440 power NAND.  
Your choice . . . . . 3/\$1.00
- Hi-Fi Headphone Speakers, MFG G.E. Make your own Hi-Fi headset, to z.  
Price . . . . . 2/\$1.50
- GIANT 80 PAGE ILLUSTRATED CATALOG jammed with BARGAINS in I.C.'s, Electronics, Optics, G.I.: Watches, etc. Free with any order or send \$25.  
Price . . . . . \$ .25

ALL ITEMS POSTAGE PAID IN THE U.S.A.

## B. & F. ENTERPRISES

PHONE: 617 532-2323  
P.D. Box 44, Hathorne, Massachusetts 01937

Circle 75 on reader service card

# MARKET CENTER

## ELECTRONICS

**PRINTED** Circuit Boards, solder plated, for magazine projects. Send magazine page or drawing of circuit pattern. 20¢ square inch. Min. \$1.75 per board. Send remittance: **GENERAL PRINTED CIRCUITS**, Box 4013, Downey, Calif. 90241

**INTRUSION** alarm. Protect your home with solid state modular system. Plans \$2.50. **BOB KINARD**, Box 11, Waltherville, Oregon 97489.

**RADIO** and TV Tubes 36¢ each. One year guaranteed. Plus many unusual electronic bargains. Free Catalog. **CORNELL 4217-E** University, San Diego, California 92105

**B & K**, Sencor test equipment, discount prices, Free catalog and price sheet. **FORDHAM RADIO**, 265 East 149th Street, Bronx, NY 10451

**CONVERT** any television to sensitive big-screen oscilloscope. Only minor changes required. No electronic experience necessary. Illustrated plans \$2.00. **RELCO-A25**, Box 10563, Houston, Texas 77018

**DISCHARGE** Ignition. Photoflash. Free catalog parts, kits. **TRANSPARK**, Carlisle, Mass. 01741

**TUBES**—Lowest prices. Foreign-American. Obsolete, receiving, special purpose, transmitting tubes. Send for tube, parts catalog. **UNITED RADIO COMPANY**, 56-R Ferry St., Newark, N.J. 07105

**"HOW TO INCREASE TRANSISTOR RADIO REPAIR PROFIT"** Write: X T R, Box 1556, Las Vegas, Nev. 89101.

Independent News Company, Inc. is pleased to announce a Retail Display Plan which includes Radio-Electronic as part of a group of magazines available for the earning of a Display Allowance.

To obtain details and a copy of the formal contract please write to Marketing Department, Independent News Co., Inc., 909 Third Avenue, New York 10022 (Attention Mr. Paul Hendershott). Under the Retail Display Plan in consideration of your acceptance and fulfillment of the terms of formal contract to be sent to you upon request you will receive a Display Allowance of 10% of the cover price per copy of each magazine in the group sold by you. This plan will become effective with all issues of the magazine group delivered to you subsequent to the date your written acceptance is received and accepted by our Company.

## CLASSIFIED ADVERTISING ORDER FORM

1	2	3	4	5
6	7	8	9	10
11	12	13	14	15
16	17	18	19	20
21	22	23	24	25
26	27	28	29	30
31	32	33	34	35

No. of Words { @ .30 Non-Commercial Rates } = \$ \_\_\_\_\_  
 { @ .70 Commercial Rate } = \$ \_\_\_\_\_  
 No. of Words in bold caps @ .10 = \$ \_\_\_\_\_

Total Enclosed \$ \_\_\_\_\_

Insert \_\_\_\_\_ time(s)

Starting with \_\_\_\_\_ issue

Payment must accompany order unless placed through accredited advertising agency 28

NAME \_\_\_\_\_

ADDRESS \_\_\_\_\_

CITY \_\_\_\_\_ STATE \_\_\_\_\_ ZIP \_\_\_\_\_

SIGNATURE \_\_\_\_\_

MAIL TO: RADIO-ELECTRONICS, CLASSIFIED AD DEPT., 200 PARK AVE. SOUTH, NEW YORK, N.Y. 10003

## ADVERTISING INDEX

**RADIO-ELECTRONICS** does not assume responsibility for any errors which may appear in the index below.

READER SERVICE CARD NO.	PAGE
Allied Radio Shack	77
75 B.F. Enterprises	87
11 B & K (Division of Dynascan Corp.)	22
73 Brooks Radio & TV Corp.	84-85
12 Channel Master	23
9 Chemtronics	16
17 Cleveland Institute of Electronics	28-31
66 Coletronics	77
C'REI, Home Study Division of McGraw-Hill Book Co.	65-66
79 Delta Electronics	86
4 Electronic Chemical Corp.	12
7 Electronic Distributors Inc.	14
Electronic Measurement Corp.	14
68 Enterprise Development Corp.	82
65 Esse Radio Co.	76
1 Grantham School of Electronics	1
64 Heald Engineering College	76
67 Heath Co.	78-81
76 International Crystal Mfg. Co.	92
72 E.F. Johnson Co.	85
74 Lafayette Radio Electronics	86
69 Laran Electronics Corp.	82
8 Leader Instrument Corp.	15
2 Mallory Distributor Products Co.	5
National Radio Institute	8-11
National Radio Institute Computer Training	73
National Technical Schools	18-21
62 Olson Electronics Inc.	75
71 Quietrol Co.	84
19 RCA Electronic Components, Test Equipment	54-57
18 RCA Institutes	54-57
3 Sams & Co., Howard W.	71
15 Sansui Electronics Corp.	7
77 Schober Organ Co.	26
14 Sencore, Inc.	Cover III
70 Shure Brothers, Inc.	25
16 Sonar Radio Corp.	83
10 Sony Corp. of America	32
3 Sprague	17
10 Sylvania	27
6 TEAC Corp. of America	13
5 Telematic Division U.X.L. Corp.	12
61 Tescom, Inc.	75
13 Ungar, Division of Eldon Ind., Inc.	24
78 Winegard Co.	Cover IV
<b>MARKET CENTER</b>	88-91
82 Alco Electronics	
Edmund Scientific Co.	
Fair Radio Sales	
Lakeside Industries	
Midwest Knife Co.	
Music Associated	
80 Park Electronic Products	
81 Polypaks	
83 Solid State Sales Surplus Center	
<b>SCHOOL DIRECTORY</b>	91
North American School of Drafting	
Valparaiso Technical Institute	



**AMPLIFIER 500 WATTS RMS stereo.** 250 RMS per board, built in protection circuit, newest semiconductor design. For musicians or stereo. Circuit guaranteed. Schematic and complete assembly plans. \$9.95 Check or money order. **AMPLIFIER DESIGN CORP.** P.O. Box 4, Rossford, Ohio 43460.

SAVE over 331/3 on a pair of one of the World's Best Speaker Systems. Shipped Direct to you from factory. Try them in your home for thirty days. **KGLL, INC.** Water Street, Lewiston, Maine 04240

**BACKGROUND MUSIC,** continuous, commercial-free. Solid-state **MUSICON SCA ADAPTER** plugs into any FM Tuner, Receiver. Line powered. 5 year guarantee! Only \$39 postpaid. **K-LAB,** Box 572R, South Norwalk, Conn. 06856

**STEREO TAPE TRANSPORT—7"** reel—2 speeds—pause control—made for famous manufacturer—50 to 15,000 Hz—with rec/play and erase heads, without case. Send M.O. or check for \$19.50 to **STEREO CENTER,** 218 Columbia St., Utica, N.Y. 13502. \$2.50 for prepaid shipping and insurance.

**TAPEMATES** makes available to you ALL 4-TRACK STEREO TAPES. ALL labels—Postpaid to your door—at tremendous savings. For free brochure write: **TAPEMATES CLUB,** 5280 RE West Pico Blvd., Los Angeles, Calif. 90019

**OLD RADIO PROGRAMS ON TAPE.** YOUR FAVORITES LIVE AGAIN. \$8.00 FOR 6 HOURS 50¢ FOR CATALOG. THOUSANDS OFFERED. **REMEMBER RADIO INC.,** 1926 CHEROKEE. NORMAN, OKLA. 73069

## EDUCATION/ INSTRUCTION

**TV TUNER REPAIRS—**Complete Course Details, 12 Repair Tricks, Many Plans. Two Lessons, all for \$1. Refundable. **FRANK BOCEK,** Box 3236 (Enterprise), Redding, Calif. 96001

**MEMORIZE,** Study: "1970 Test-Answers" for FCC First and Second Class License. plus—"Self-Study Ability Test." Proven. \$5.00. **COMMAND,** Box 26348-E. San Francisco, Calif. 94126

## PEP'S Dollar Sale \$1 Money Back guarantee \$1

- 1 Amp Silicon Rectifier** choice of package  
**Bullet—Miniature Glass-Metal**
- 5-800V units \$1.00
  - 4-1000V units \$1.00
  - 3-1200V units \$1.00
- 3 AMP Epoxy Package**
- 10-100V units \$1.00
  - 5-400V units \$1.00
  - 2-1000V units \$1.00
- Gen Purpose PNP Germ Transistor Similar to 2N404**
- 8 For \$1.00

- 2 AMP BULLET RECTIFIERS**
- 10-200V—\$1.00
  - 8-100V—\$1.00
  - 6-500V—\$1.00
- GERM GLASS DIODES DO7 GEN PURPOSE**
- 20 Units \$1.00
  - Replaces 1N-34 1N-60 1N-64 1N-295
- SILICON STUD MOUNT 20 AMP**
- 3-100V units \$1.00
  - 1-1000V unit \$1.50

PRV	1 Amp	3 Amp	7 Amp
50	.20	.25	.30
100	.25	.30	.35
200	.40	.45	.50
300	.60	.70	.80
400	.75	.85	.95
500	—	—	1.00
600	—	—	1.30

PRV	1Amp	3Amp	6Amp	10Amp	15Amp
100	.40	.50	.75	1.00	1.20
200	.65	.75	1.00	1.40	1.80
300	1.00	1.10	1.25	1.90	2.20
400	1.30	1.40	1.80	2.30	2.60
500	1.60	1.80	2.10	2.75	3.10

PRV	2Amp	3Amp	5Amp	10Amp
50V	1.25	1.35	1.50	1.70
100V	1.50	1.60	1.75	1.95
200V	1.75	1.85	2.00	2.20
400V	2.00	2.10	2.25	2.45
600V	2.50	2.60	2.75	2.95
800V	3.00	3.10	3.25	3.45

## PARK ELECTRONIC PRODUCTS

P. O. Box 78 N. Salem, N. H. 03073  
Tel. (603) 893-0276

NO SALES TAX WE PAY POSTAGE

Circle 80 on reader service card

FEBRUARY 1971

## 4,000 BIT MEMORY \$8.50

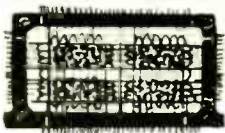

From IBM Computers, Guaranteed! W/Spec Sheets

## GIANT SALE ON NEW TTL TEXAS & NATIONAL ICs

Guaranteed! W/Spec Sheets

Any 3 — 10% Discount!

Type*	Description	SALE
SN7400N	Quad 2 input NAND gate	\$.88
SN7401N	Quad 2 input NAND gate*	.88
SN7402N	Quad 2 input NOR gate	.88
SN7404N	Hex inverter	.99
SN7410N	Triple 3 input NAND gate	.88
SN7420N	Dual 4 input NAND gate	.88
SN7430N	8 input NAND gate	.88
SN7440N	Dual 4 input NAND gate*	.88
SN7441N	BCD-to-decimal decoder-driver	4.95
SN7442N	BCD-to-decimal decoder	4.50
SN7447N	BCD-to-7 seg decoder-driver	4.95
SN7460N	Dual 4 input expander	.88
SN7473N	Dual J-K master slave flip flop	1.19
SN7474N	Dual D-type edge triggered flip flop	1.19
SN7475N	Quad bistable latch	2.95
SN7476N	Dual J-K master slave flip flop	1.19
SN7483N	4 bit binary full adder	4.95
SN7490N	Decade counter	3.95
SN7492N	Divide-by-twelve counter	3.95
SN7493N	4 bit binary counter	3.95
SN7495N	4 bit right-shift left-shift register	4.95

10¢ Catalog on Fiber Optics, 'ICs', Semis, Parts

Terms: add postage. Rated: net 30, coll's 25%. Phone Orders: Wakefield, Mass. (617) 245-3829 Retail: 211 Allison, St., Wakefield, Mass.

## POLY PAKS

P.O. BOX 942 R LYNNFIELD, MASS 01940

**1971 SPECIAL!  
FREE! SUBTRACT  
\$1 WITH EVERY  
\$10 PURCHASE**

## SPRAGUE- IC's

Your Choice

3 for \$1

- 908 Full Adder
- 909 Buffer
- 912 Half Adder
- 913 Shift Register
- 915 Dual 3 In. Gate
- 921 Dual 2 In. Gate
- 940 JK Flip Flop
- 960 Dual Buffer

RTL



Guaranteed! W/Spec Sheets

## POPULAR "LINE LITERS"

<input type="checkbox"/>	10 — 1 watt zeners 5 to 12 volts	1.00
<input type="checkbox"/>	741C Freq. Comp. 709 Op. amplifier	1.80
<input type="checkbox"/>	10 — 1Amp 800 pV silicon rectifiers	1.00
<input type="checkbox"/>	8 — 1Amp 1000 pV silicon rectifiers	1.00
<input type="checkbox"/>	1 — 2N3055 NPN 100V 15A TO3 trans	1.19
<input type="checkbox"/>	1 — 1N2929 Tunnel diode, Centralab	1.19
<input type="checkbox"/>	4 — ER-900 Trigger diodes, triacs	.99
<input type="checkbox"/>	2 — 2N2419 Unijunction transistors	1.19
<input type="checkbox"/>	25 GE 1Amp silicon rects. to 1000V	1.00
<input type="checkbox"/>	5 — 3Amp 600V top hats silicon	.99
<input type="checkbox"/>	4 — 3Amp 800V top hats silicon	.99
<input type="checkbox"/>	8 Transistor stereo preamplifier	1.98

## FAIRCHILD IC SALE LINEAR AMP

\$1.19 each



- 703 RF-IF Amp
- 709 Operational Amp
- 710 Hi-Speed Diff
- 711 Dual Comparator

- 1-Watt Audio "IC amplifier" WC334
- 1.49
- 1 Voltage Regulator, 0 to 40 VDC Positive
- 1.19
- 4 — 2N4409 Nixie tube drivers transist
- 1.00
- 1 — 15Amp 200 PRV Triac stud
- 1.49
- 2 Unijunction transistors 2N1891
- 1.19
- 2 N-Channel plastic Fets 2N3819 Texas
- 1.19

## COUNTING SYSTEM

3 PC. KIT

\$11



Includes SN7490 decade counter, SN7441 (BCD) decoder-driver, SN7475 quad latch with hookups instructions

NIXIE\* TUBE \$5.95

(0-9), wide angle Similar to Burroughs

Circle 81 on reader service card

## Protect and Preserve Your Copies of Radio-Electronics

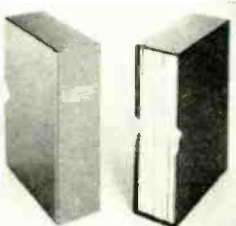

An elegant, durable Library Case will protect an entire year's copies from dust and wear. At the same time, it will enable you to

conserve valuable space and reduce book-case clutter.

With Maroon simulated leather back, and black sides, the attractive case should be a handsome addition to your library. (16-k gold lettering is used to give maximum legibility.) Each Library Case also includes gold transfer so you can print the year on it. To order, send your check with the order form, below:

Clip & Mail with your check to:  
**JESSE JONES BOX CORP.**  
Box 5120, Philadelphia, Pa. 19141

name .....

address .....

city .....

state .....zip .....

Please send me ..... RADIO-ELECTRONICS Library Cases at \$3.50 per Case. (Payment must accompany order.)

Orders outside U.S.A. not accepted



## FREE Catalog Of The WORLD'S FINEST GOV'T SURPLUS ELECTRONIC BARGAINS

Now BIGGER and BETTER Than Ever!

—MAIL THIS COUPON NOW—

NAME: \_\_\_\_\_  
ADDRESS: \_\_\_\_\_  
CITY: \_\_\_\_\_ STATE: \_\_\_\_\_ ZIP: \_\_\_\_\_

For your FREE copy, fill out coupon and mail. Dept. RE

**FAIR RADIO SALES**  
1016 E. EUREKA • Box 1105 • LIMA, OHIO • 45802

ENJOY THE "MUSIC ONLY" FM PROGRAMS

## M. A. D.

**MUSIC ASSOCIATED'S DETECTOR** for continuous, commercial-free music with ANY FM tuner or receiver



Kit \$49.50 Wired \$75.00 Cover \$4.95 List of FM stations with SCA authorization \$1.00. Excellent F.M. Monaural Tuner with M.P.X. Jack \$50.00  
**MUSIC ASSOCIATED**  
65 Glenwood Rd.,  
Upper Montclair, N.J. 07043  
phone 201-744-3387



KEEP PACE WITH SPACE AGE! SEE MOON SHOTS—LANDINGS, SPACE FLIGHTS, CLOSE-UP!

# AMAZING SCIENCE BUYS

for FUN, STUDY or PROFIT

**FREE GIANT CATALOG!**

## NEW \$99.50 HELIUM-NEON LASER!

Completely assembled, instant-starting w/ three times power output of comparable models. Steady, ripple-free light of moderate (safe) power. Excellent collimation. Particularly useful for studies, experiments in holography, interferometry, diffraction, optical alignment. Simple and safe to use—just plug in, switch on. The 4 1/2 lb. unit reaches 75% power in 2 secs.; full power, typically 0.5 milliwatt (0.3 mW minimum) in 3 mins. Beam divergence only 2 milliradians far ahead of competition! beam only 2 cms at 40 ft. Stock No. 79.004EH ..... \$99.50 Ppd. SINGLE MODE MODEL Stock No. 79.008EH ..... \$129.50 Ppd.

**PSYCHEDELIC LIGHTING HANDBOOK**  
100 information packed pages! Fully explains latest in psychedelic lighting equipment, technical details, etc. Covers all facets of psychedelic light-show production including strobes, black lights, projectors, crystals, organic slides, mirrors, color organs, polarized color light beams, Musler-Vision, etc. 8 1/2" x 11" looseleaf paper for 3 ring binder. Stock No. 9100EH ..... \$3.00 Ppd.

**LONG-WAVE BLACK LIGHT FIXTURE**  
Extremely versatile, compactly designed, long wave (3200-4000 angstroms) black light (ultraviolet) fixture—eliminates harmful shorter wave ultraviolet rays. Use to identify minerals, fungi, bacteria—check for surface flaws, oil and gas leakage—perfect for displays with fluorescent paper, paints, chalk, crayons, trace powder. Incl. adjustable aluminum reflector, push-pull switch, connecting plug. Mount vert., horiz., or on corner. 10" L., 1 1/2" W., 1 1/4" H. Stock No. 70.364EH ..... \$12.50 Ppd. No. 60.124EH... REPLACEMENT BULB ..... \$4.75 Ppd.

**MIRRORED BALLS BOUNCE LIGHT**  
Yesterday's ballroom echo in mirrored lights that ratchet to the beat of today's discotheque. Up to 1,000 lustrous, clear, hand-made glass mirrors on each ball create fantastic lighting effects. Motorized—their reflections blow the mind! Ideal for light shows, displays, restaurants, hotels, modern stores. Stock No. 71.066EH ..... (12" Diam.) ..... \$30.00 Ppd. Stock No. 85.180EH ..... (16" Diam.) ..... \$75.00 FOB Stock No. 71.065EH ..... (8" Diam.) ..... \$17.50 Ppd. Stock No. 60.744EH ..... CEILING MOTOR ..... \$12.50

**BLACK-LIGHT MIGHTY MITES**  
Relatively small (12") fixtures give surprisingly bright blacklight. Mirror-finished reflector makes instant starting 3-watt, high-intensity light look like 10-watt. Up to 5,000 hours of safe, long-wave (3660A) black-light to really turn on parties, light & theatrical shows, psychedelic decors, holiday decorations, bulb and starter. Stands upright or horizontal. Alum. case. Stock No. 71.274EH ..... \$14.95 Ppd. DELUXE OUTDOOR/INDOOR MODEL Stock No. 71.299EH ..... \$19.95 Ppd.

**25X to 900X LABORATORY MICROSCOPE**  
Sturdy, monocular-type, 3 Coated Achromatic parfocal objectives—5X (0.10 NA), 10X (0.25 NA), 60X (0.85 NA); triple revolving nose-piece. Automatic focusing stop prevents damage to objectives and slides. Fixed 160mm tube. Rack & pinion coarse focusing & fine micrometer type slide adjustments. 3 Hyegeinall eye-pieces: 5X, 10X, 15X. Bakelite stage 4-1/2" x 4-5/16", 2 stage clips accept Edmund graduated mesh, stage No. 30.060—Substage equipment: Fixed-condenser lens, iris diaphragm, 1-7/8" diam. plano-convex mirror. Stock No. 85.049EH.....(11 3/4" H., 11 lbs. W.), \$99.75 F.O.B.

**MAIL COUPON FOR GIANT FREE CATALOG**

**148 PAGES—1000's OF BARGAINS**  
Completely new 1971 edition. 500 items, categories, illustrations. Dozens of electrical and electromagnetics parts, accessories. Enormous selection of Astronomical Telescopes, Unique Lighting Items, Microscopes, Binoculars, Magnifiers, Magnets, Lenses, Prisms. Many war surplus items. Mail coupon for catalog.

**EDMUND SCIENTIFIC CO.**  
300 EDSORP BUILDING  
BARRINGTON, N.J. 08007  
NAME \_\_\_\_\_  
ADDRESS \_\_\_\_\_  
CITY \_\_\_\_\_ STATE \_\_\_\_\_ ZIP \_\_\_\_\_

## SPECIAL VISUAL EFFECTS PROJECTOR SET

Fantastic variety. Incredibly beautiful. Create floating, exploding, fiery bursts of color like "Symphony of Spheres", "Chromatic Starbursts", "Crystal Starbursts". Features 35mm 8mm W. fan cooled projector, produces big image at short distance. Accepts two 9" diam. wheels (Dry Kaleidoscope & Hexidroscope), 2 cylindrical accessories (8" Colored Cloud & 3" Hexidroscope w/six internal mirrored walls). Complete instructions. Stock No. 71.212EH ..... \$79.50 Ppd.

## 3" ASTRONOMICAL TELESCOPE

See moon shots, orbits, star-phases of Venus, planets close up. 60 to 180 power. Aluminized overcoated 3" diameter f/10 primary mirror, ventilated cell. Equatorial mount with locks on both axes. Equipped with 60X eyepiece and mounted Barlow lens, X line telescope hardware tripod. FREE: "STAR CHART": 272-page "HANDBOOK OF HEAVENS": "HOW TO USE YOUR TELESCOPE" Stock No. 85.050EH ..... \$29.95 Ppd. Stock No. 85.105EH ..... 4" ..... \$94.50 FOB Stock No. 85.086EH ..... 6" ..... \$239.50 FOB

## ROTATING MULTI-COLORED LIGHT

Dazzling colors stream endlessly from constantly rotating light. Faceted, transparent globe has lowered drum inside with red, green, blue & yellow stars. Bulb heat rotates drum which projects flickering star points on walls, ceilings, etc. while individual globe facets present constantly changing array of brilliant colors. 9 1/2" star—approx. 12" high on bell-shaped base. Surprisingly light. Easily used on table, TV, fireplace, or Xmas tree top. Stock No. 71.000EH ..... \$7.00 Ppd.

## 1st LOW-COST XENON STROBE!

Price breakthrough in bright, reliable electronic strobes. 50W/Second xenon tube. Variable flash rate—60 to 500 per minute. Long life—more than 1,000,000 flashes. Printed circuit board design. Safe, durable Bakelite case. Externally mounted bulb. Plastic shield. 3 1/2 x 3 x 2 1/2. 14 oz. Perfect for psychedelic, stage-action lighting effects for home light shows, parties, displays. Stock No. 71.342EH ..... \$24.95 Ppd. BUILD-IT-YOURSELF STROBE KIT Stock No. 71.943EH ..... \$19.95 Ppd.

## 1st QUALITY OPAQUE UNDER \$200

Terrific Buy! Top Quality! Projects brilliant, sharp 4 1/2 ft. sq. image from 8" using up to 5" x 3" obj. h&w illustrations. Retains all original colors, proportions. Enlarges drawings, coins, maps, etc. Revolutionary peanut-size quartz halogen lamp (50 hr. life). 200mm anastigmatic lens (f3.5, 8" F.L.) unique internal reflecting system give maximum brightness, entire field focus. Can be used upside down. Turbo-cooled. 5 1/2 ft. cord. Stock No. 71.272EH (Wt. 11 1/4 lbs.) ..... \$89.75 Ppd.

## ASTRONOMICAL TELESCOPE KITS

Grind your own mirror for powerful telescopes. Kits contain the annealed pyrex mirror blank, tool, abrasives, diagonal mirror, and eyepiece lenses. Instructions you build ratio in value from \$75 to hundreds of dollars. 4 1/2" DIAMETER—3" Thick Stock No. 70.003EH ..... \$10.75 Ppd. 6" DIAMETER—4" Thick Stock No. 70.004EH ..... \$13.95 Ppd. 8" DIAMETER—13" Thick Stock No. 70.005EH ..... \$21.50 Ppd. 10" DIAMETER—1 1/2" Thick Stock No. 70.006EH ..... \$52.50 FOB

## 1st LOW-COST VACUUM PUMP!

Nothing like it! Top-quality hand-held pump produces & maintains 25" of vacuum. Has instant release tab. 1 1/2" diam. stainless gauge (0-30"). 100's of uses—siphon noxious fluids, evacuate bell jars and castings, clean, retrieve, lift sterile objects, demonstrate Marsden's hemispheres, bleed fuel lines, check leaks, etc. Lifts 40 lbs. with included "T" much more w/ larger cup. Stock No. 71.301EH ..... \$12.00 Ppd. No. 71.300EH (without gauge/lifter) ..... 5.50 Ppd.

# U.S. GOV'T ELECTRONIC SURPLUS

Nationally Known-World Famous SURPLUS CENTER offers finest, most expensive, Government Surplus electronic units and components at a fraction of their original acquisition cost.

## IBM COMPUTER POWER SUPPLY

• (ITEM #22-934) - Expensive, regulated unit. Fine for college labs, research etc's, service shops, etc. Fine 10" case a wide range of voltages. DC output voltages: 6, 15, 36, etc. Wide range of AC voltages available. • Finest transformer, filters, transistor load regulation system, independent of line voltage fluctuations. • Contains two separate rectifier systems. Unit is furnished without small "topulating card" which can be easily made available. Data and circuit diagram furnished. 10" x 17" x 14" (145 lbs.). Cost Gov't Over \$500.00 ..... \$24.95 ONCE-IN-A-LIFETIME SPECIAL

## BURGLAR-FIRE ALARM SYSTEM

• (ITEM #1135-A) - Ideal alarm system given details of fire or break-in. Operates on 115-V AC. Control unit, 2-Kelco flash tube, 2-megohm resistor, 3-door lock, 2-bell, 2-bell, 100 ft. wire, instructions, 8 1/2" x 7 1/2" x 3 1/2" (1 lb.) Cost Gov't Over \$29.95 ..... \$29.95

## STANDARD DIAL TELEPHONE

• (ITEM #715) - Standard, commercial telephone was an used throughout U.S.A. Attractive looking design, like new condition. Use for collecting phone to private system or connect several phones together for local intercom system. Full instructions are furnished. 8 1/2" x 8 1/2" x 12" (1 lb.) Cost Gov't Over \$24.50 ..... \$7.49

## STEP-BY-STEP TELEPHONE SWITCH

• (ITEM #7-905) - Amazing telephone selector switch. Great experimental item. When used with two-line telephone dial will select any number from 0 to 100. Make intercom in private system. Use to turn on remote lights, start motors, etc. Complete with contact bank, 12" x 6" x 5" (1 1/2 lbs.). Cost Gov't Over \$60.00 ..... \$6.29 • Telephone dial for use with three wires. Order as (Item #700) ..... \$1.97

## MAGNETIC DIGITAL COUNTER (12 to 18-VDC)

• (ITEM #1-959) - Use to count electrically. Use in count number of items done or opened after business is closed, to show changing price, laboratory uses, etc. Will count 1 for each pulse and will transfer 1000 count to next unit. 2 1/2" x 1 1/2" x 1 1/2" (1 1/2 lbs.). Orig. Cost Over \$19.00 Each \$1.99 Three For \$4.99

## TYPICAL BUYS FROM OUR 1970 CATALOGS

- \$ 10.00 115-Volt DPDT Relays ..... \$1.69
- \$101.00 Regulated Transformer, Wide Range ..... \$14.91
- \$ 75.00 20-Relay Telephone Panel ..... \$4.39
- \$250.00 Gyroscope, Twin Rotor, 24V ..... \$9.89

## AC PROGRAM TIMING CLOCK

• (ITEM #158) - Zenith 115-VAC unit. Use for periodic signaling, work breaks, class run on radio, etc. Ad. has permit 6V-0.015 switching any time in 24-hour period. Also has "stop-a-day" feature. Can be multiple programmed. 12 amp. 60 cycle. 8 1/2" x 6 1/2" x 4" (4 lbs.). Cost Gov't Over \$30.00 ..... \$15.75

## SNAP AROUND VOLT-OHM-AMMETER

• (ITEM #21-844) - Measures AC current without opening the line. Snap-on design. Snap the meter around the conductor. Reads currents from 25 to 125 amps. Reads voltages in 100 reads show up to 500. Test meters, amplifiers, etc. Three current ranges, top voltage ranges. With case, test leads. 7 1/2" x 3" x 1 1/2". Reg. Price \$39.95 ..... \$36.90 (2 lbs.)

## SPECIAL SALE Correspondence Course In ELECTRICAL ENGINEERING

\$8.79 Prepared in U.S.A. \$10.79 Outside U.S.A.

• (ITEM #A180) - Obtain technical training at low cost! Lincoln Engineering School has introduced Correspondence Courses because of rising costs. A limited number of 3 level of Engineering Courses are available, but without the classroom grading system. The course consists of 15 lesson books, each with associated exams and standard answers. Book describing price winning Home Experimental Laboratory Bench furnished at no extra cost.

## RUNNING TIME METER

• (ITEM #2188) - Greatest number of operating hours of electric lights and electrical devices such as refrigerators, furnaces, etc. Records total hours, tenths and hundredths up to 9,999.99 hours. For 115-volt, 60-cycle. Size 4 1/2" x 3 1/2" x 2 1/2", shipping weight 2 lbs. Cost Gov't Over \$39.00 ..... \$4.39

## COMPUTER TRANSISTORS ON HEAT SINKS

IBM Computer Quality Units • (22-928) - This consists of one 150-watt power transistor, one heat sink, silicon aluminum heat sink, many experimental uses. (1 lb.) Cost Gov't Over \$10.00 ..... \$1.99 • (22-915) - This consists of one 150-watt power transistor, one heat sink, silicon aluminum heat sink, many experimental uses. (1 lb.) Cost Gov't Over \$25.00 ..... \$4.91

All items shipped f.o.b. Lincoln, Nebr. Order Direct From Ad. Money Back Guarantee. **SURPLUS CENTER** DEPT. RE-021 LINCOLN, NEBR. 68501

**EDMUND SCIENTIFIC CO.** 300 EDSORP BLDG. BARRINGTON, NEW JERSEY 08007  
ORDER BY STOCK NUMBER • SEND CHECK OR MONEY ORDER • MONEY-BACK GUARANTEE



# MARKET CENTER

**NEW! COMPUTER-TUTOR** slide rule will teach YOU how computers get their answers. Send \$2.95 to: **COMPUTER-TUTOR**, Dept. R2, Box 242, Orchard Park, N.Y. 14127.

**COLOR TELEVISION, IT'S ANTENNA** How they work, facts you should know, 2 booklets \$1.00. **BOOKLETS**, Box 90218x, Los Angeles, Calif. 90009.

## GOVERNMENT SURPLUS

**JEEPS** Typically from \$53.90 . . . Trucks from \$78.40 . . . Airplanes, Typewriters, Boats, Clothing, Camping, Sporting, Photographic, Electronics Equipment. Wide Variety, Condition. 100,000 Bid Bargains Direct from Government Nationwide. Complete Sales Directory and Surplus Categories Catalog. \$1.00 (Deductible First

\$10.00 Order From Our Separate Included Catalog.) **SURPLUS SERVICE**, Box 820-REL, Holland, Mich. 49423

## INVENTIONS & PATENTS

**INVENTORS:** Protect your Ideas! Free "Recommended Procedure". **WASHINGTON INVENTORS SERVICE**, 422X Washington Building, Washington, D.C. 20005

**FREE "Directory of 500 Corporations Seeking New Products"**. For information regarding development, sale, licensing of your patented/unpatented invention. Write: **RAYMOND LEE ORGANIZATION**, 230-U Park Avenue, New York City 10017

**INVENTIONS Wanted.** Patented; Unpatented. **GLOBAL MARKETING**, 2420-AE 77th Ave., Oakland, Calif. 94605

## GENERAL

**JAPANESE NEW PRODUCTS MONTHLY!** \$1.00 Refundable. **DEERE**, 10639 Riverside, North Hollywood, Calif. 91602

**BOOKS**, more than 20 current listings on audio, electronics, mathematics. Descriptive list free from author. **NORMAN CROWHURST**, Rte. 3, Box 324-RE, Dallas, Oregon 97338

## WANTED

**QUICK CASH . . .** for Electronic EQUIPMENT, COMPONENTS, unused TUBES. Send list now! **BARRY**, 512 Broadway, New York, N.Y. 10012, 212 WALKER 5-7000

**10¢ SALE**  
GUARANTEED  
10 YEARS



The knife for hunting, fishing and all around use. Mirror polished, imported stainless steel blade honed to a razor's edge. Rugged. Opens with flick of finger. Locks into position. Blade will not close when in use. Press button in handle to close. Safety finger guard. Sure-grip handle. Balanced for target throwing. IF BROKEN WITHIN 10 YEARS WE WILL REPLACE AT NO CHARGE! Use 30 days. Money back if not pleased. Special 1c Sale. **R.G. PRICE \$1.98.** Send \$1.98 & receive 2 knives. Add 49c postage, handling. **Remit TOTAL \$2.48 for 2 knives.** **ORDER NOW!** Midwest Knife Co., 6043 S. Western Ave., Dept. D.C.-21, Chicago, Ill. 60620. Est. 1936.

**CLASSIFIED COMMERCIAL RATE** (for firms or individuals offering commercial products or services), 70¢ per word . . . minimum 10 words.

**NON-COMMERCIAL RATE** (for individuals who want to buy or sell personal items) 30¢ per word . . . no minimum.

**FIRST WORD and NAME** set in bold caps at no extra charge. Additional bold face at 10¢ per word. Payment must accompany all ads except those placed by accredited advertising agencies. 10% discount on 12 consecutive insertions, if paid in advance. Misleading or objectionable ads not accepted. Copy for April issue must reach us before Feb. 5.

## 5-RANGE DC MICROAMP 29.95 Meter



Ranges: 50-100-250-500-1000uA. Extra-wide meter with mirrored scale. With test leads. Bakelite case 7 1/4 x 4 3/8 x 2 1/2". For schools, shops, labs. SM301

**ALCO** Order: Box 1349RE SHIPPED POSTPAID  
Lawrence, MA 01842 Other Functions Too!

**Rebuild Your Own Picture Tubes?**  
With Lakeside Industries precision equipment, you can rebuild any picture tube!

For complete details, send name, address, zip code to:

**LAKESIDE INDUSTRIES**  
5234 N. Clark St.  
Chicago, Ill. 60640  
Phone: 312-271-3399



# SCHOOL DIRECTORY

GET INTO

## ELECTRONICS

V.T.I. training leads to success as technicians, field engineers, specialists in communications, guided missiles, computers, radar and automation. Basic & advanced courses in theory & laboratory. Electronic Engineering Technology & Electronic Technology curricula both available. Associate degree in 29 mos. B.S. also obtainable. G.I. approved. Graduates in all branches of electronics with major companies. Start Sept. Feb. Dorms, campus. High school graduate or equivalent. Catalog:

**VALPARAISO TECHNICAL INSTITUTE**  
Dept. C, Valparaiso, Indiana 46383



## LEARN DRAFTING AT HOME

U.S. Labor Dept. says "42% more Draftsmen needed next 10 years." Send for FREE "DRAFTING CAREER KIT." No salesman will call.

NAME \_\_\_\_\_ AGE \_\_\_\_\_  
ADDRESS \_\_\_\_\_  
CITY \_\_\_\_\_ STATE \_\_\_\_\_ ZIP \_\_\_\_\_  
NORTH AMERICAN SCHOOL OF DRAFTING, Dept. 13082  
Accredited National Home Study Council 4500 Campus Dr., Newport, Calif. 92660

## INTEGRATED CIRCUITS / RECTIFIERS SEMICONDUCTORS / TRIACS

### TRIACS

PRV	1A	5A	15A
100	.50	.70	1.00
200	.80	1.25	1.40
300	1.10	1.60	1.80
400	1.40	1.90	2.20
500	1.75	2.20	3.00

**ER900 TRIGGER DIODES.** These bidirectional trigger diodes are one of the best and cheapest methods to trigger SCR's and triacs . . . 3/\$1.00

### UNIUNCTIONS!

Similar to 2N2419. RBB of 5-7 stand off ratio of .6 and Ip of 12 with data sheet \$.80

N-CHANNEL FET'S TO-18 plastic units, low noise, low leakage, 25 volts source to gate, 50 ma gate current Gain to 9000  $\mu$ mho's. \$ .60

2N4303. P channel FET with a Q ms of 2000  $\mu$ ohms .....\$ .95

MM 2260. An NPN TO-5 silicon unit used for video output circuits in transistorized TV's, with a gain of 35 and Vcb of 175 \$ .75

### MOUNTING HARDWARE KITS.

These kits are used to mount our SCR's Zeners and Rectifiers etc. 6x32 stud (3, 12 amp rectifiers, \$3.00

7A SCR's 6 sets/\$1.00  
1/2x28 stud (30 amp. rectifiers, 20 amps SCR's) 4 sets/\$1.00

### MRTL IC's

908 FULL ADDER	.75
912 HALF ADDER	.50
913 REGISTER	.50
940 JK FLIP FLOP	.50

### TTL IC SERIES

7441 BCD DECIMAL DECODER	\$2.50
7474 DUAL FLIP FLOP	\$1.25
7475 QUAD BISTABLE LATCH	\$2.00
7476 DUAL JK MASTER-SLAVE JK FLIP FLOP	\$1.50
7490 DECADE COUNTER	\$2.50
7492 DIVIDE BY TWELVE	\$2.50
7493 4 BIT BINARY COUNTER	\$2.50

### Silicon Power Rectifiers

PRV	3A	12A	30A
100	.09	.24	.50
200	.16	.35	.80
400	.20	.45	1.20
600	.30	.70	1.50
800	.40	.85	1.80
1000	.50	1.10	2.20

Terms: FOB Cambridge, Mass. Send check or Money Order. Include Postage. Average Wt. per package 1/2 lb. No. C.O.D.'s. Minimum Order \$3.00

### FIBRE OPTICS

1/32" 2.5 mil. fibers in PVC packet. \$ .33/ft.

### COMPLETE LIGHT GUIDE BUNDLE

consisting of an 11" length of 1/10" dia. fiber optics with bound ends. \$4.00 ea.

Controlled Avalanche or Epoxy Rectifiers 1 AMP.

PRV	PRV
100	.07
200	.09
400	.11
600	.16
800	.20
1000	.30

### LINEAR CIRCUITS

709C operational Amp . . . \$1.30  
SE 501 Video Amp . . . \$1.00  
SE 518 Voltage Comparator . . . \$1.00

### Silicon Control Rectifiers

PRV	3A	7A	20A	70A
50	.30	.35	.70	
100	.40	.55	1.00	4.00
200	.60	.80	1.30	8.00
300	.80	1.00	1.70	
400	1.00	1.30	2.10	12.00
500	1.25	1.60	2.50	
600	1.50	1.90	3.00	16.00

**BIGGER AND BETTER BARGAINS.**

Send for our latest catalog featuring Transistors and Rectifiers; 325 Elm St., Cambridge, Mass.

**SOLID**

Post Office Box 74D

**TATE**

Somerville, Mass. 02143

**SALES**

Tel. (617) 547-4005

Circle 83 on reader service card

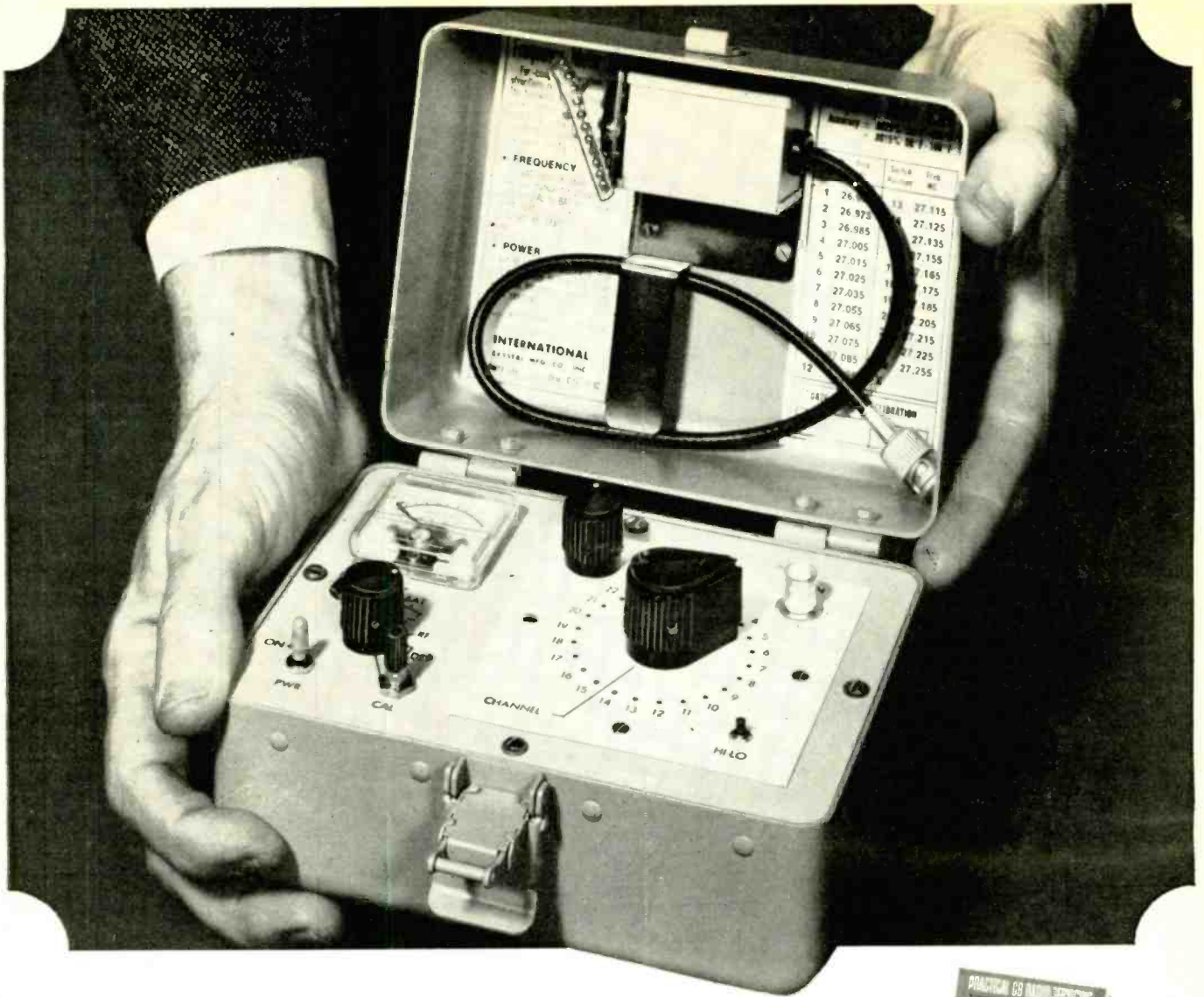

## three in one...

### INTERNATIONAL'S 6024 FREQUENCY METER

- SECONDARY FREQUENCY STANDARD
- SIGNAL GENERATOR
- POWER METER

The 6024 packs three test instruments into one small package for fast, professional servicing on all makes of Citizens Radio transceivers. You have at the flick of a switch, a SECONDARY FREQUENCY STANDARD, range 26.965 to 27.255 MHz with Counter Circuit, zero to 2500 Hz; SIGNAL GENERATOR, 26.965 to 27.555 MHz and DUMMY LOAD/POWER METER, up to 5 watts.

Order your International 6024 today!

Complete with connecting cable, dummy load, rechargeable battery and charger. **\$345<sup>00</sup>**

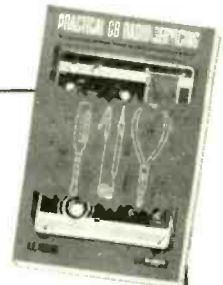

### PRACTICAL CB RADIO SERVICING

*A reference manual for CB's, servicemen and students*

This book covers virtually every servicing problem faced by CB radio enthusiasts, technicians, servicemen, and students. It provides all the theory and detailed procedures needed to repair and maintain equipment in a professional manner. Ideal tool for spot-testing and trouble shooting. Complete with tables and charts.

**\$4.75** postpaid

WRITE FOR CATALOG



CRYSTAL MFG. CO., INC.  
10 NO. LEE • OKLA. CITY, OKLA. 73102

Circle 76 on reader service card



# NOW you can measure resistors accurately **IN CIRCUIT!**

in solid state devices



**FE20 HI-LO**  
with hi-voltage probe and large  
six-inch meter **\$129.50**



**FE21 HI-LO**  
with 4½-inch  
meter **\$99.50**

## WITH THE NEW HI-LO FIELD EFFECT MULTIMETERS

**USES ONLY .08 VOLTS TO POWER OHMMETER TO PREVENT TRANSISTORS FROM CONDUCTING AND UPSETTING READINGS**

Look at these extra features to see why the Hi-Lo meter belongs on your want list:

- Unbelievable specifications of 15 megohm input impedance on DC and 12 megohms on AC
- Laboratory accuracy of 1.5 percent on DC and 3 percent on AC
- 9 DC voltage ranges from as low as .1 volts full scale to 1000 volts
- 3 hi-voltage ranges of 3 KV, 10 KV and 30 KV
- 9 DC zero center ranges from .05 volts to 500 volts . . . a must for delicate transistor bias measurements
- 7 resistance ranges from 1000 ohms full scale to 1000 megohms

- 9 DC current ranges from 100 microamps to 1 amp
- Automatic built-in battery test . . . never a worry about rundown batteries, just push the switches under the meter and read.
- Standard .6 amp fuse to protect the ohms and milliamps scales if voltage or overload is accidentally applied. No more need to return the meter to factory for repair . . . just replace the fuse.
- Special probe with 100K isolation resistor in probe to prevent AC pickup or to prevent loading oscillator circuits. Leave in normal position for most tests.

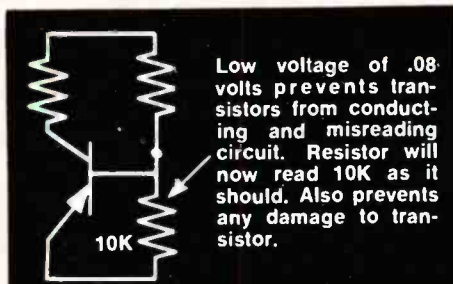

**Here is why you should have both Hi and Lo battery voltages for correct in-circuit resistance measurements in solid state circuits:**

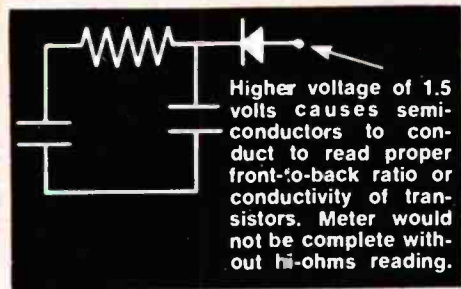

**SENCORE** INC. 3200 Sencore Drive • Sioux Falls, South Dakota 57107

Circle 77 on reader service card

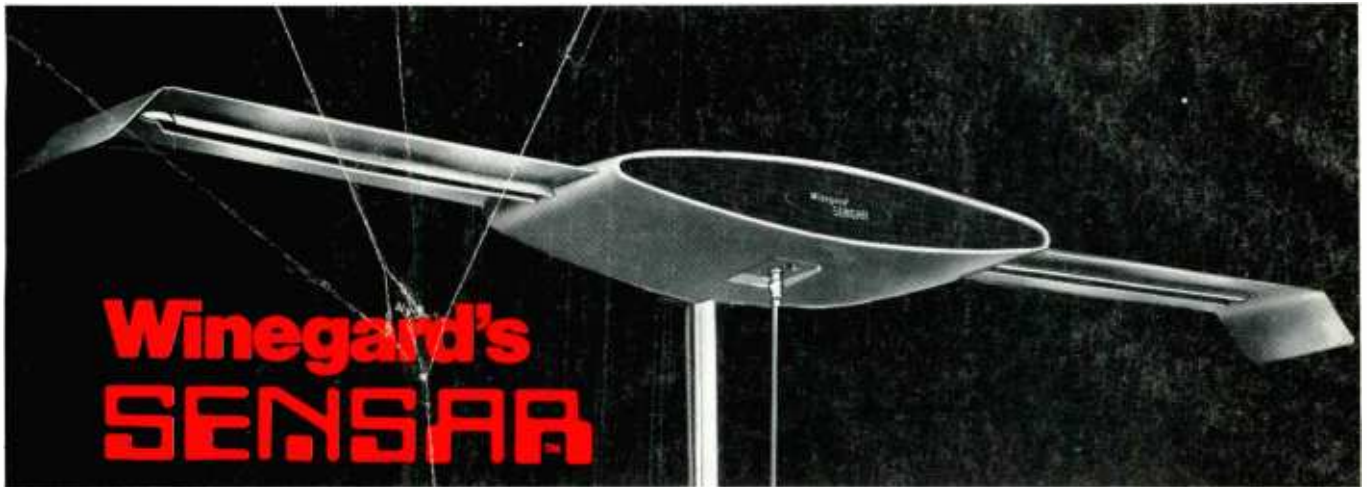

## The first miniature outdoor TV antenna designed for color.

Sensar is the first miniature antenna that's going to become a big antenna. The miniature part, obviously, is the size—only 46" x 6" x 3¼". What's not so obvious, until you see it for yourself, is the big, big performance.

As a matter of fact, Sensar will perform as well as a much larger antenna on all VHF and UHF channels (2 to 83), in color and black & white, and, depending on the reception problems unique to any area, from as far as 40 miles and more from tv transmitters.

Of course, to do all those things, Sensar must have something no other antenna has. And it does. Space-age solid-state circuitry,

coupled with Winegard engineering capabilities. Together, they make Sensar sensitive and powerful enough to match the big antennas, yet small enough to fit under an eaves, outside an apartment window, even in the attic.

Naturally, because of its size, the weatherproof, windproof Sensar is the easiest and quickest antenna to install. We've even developed special mounts to make installation easier—a 30-inch high tripod roof mount, a combination wall, window and chimney mount, and a mount for travel trailers, mobile homes and boats. And because Sensar uses 75-ohm coaxial cable, we offer 15, 25, 50, 75

and 100-foot cable kits with connectors already attached.

You see, we figure everybody's going to want a Winegard Sensar. To make sure everybody knows about Sensar, we're advertising it in Life Magazine and Sunday Newspaper Magazines. We have plenty of in-store sales aids, too, including sell-on-sight packaging, banners and floor displays.

About the only thing we haven't told you about Sensar is the price. Only \$49.88 (Fair Trade List) for the SR-20 Solid-State model with VU Band Separator. A small price for a small wonder. More information? Call your Winegard distributor.

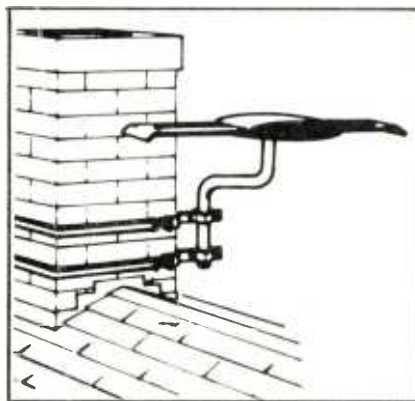
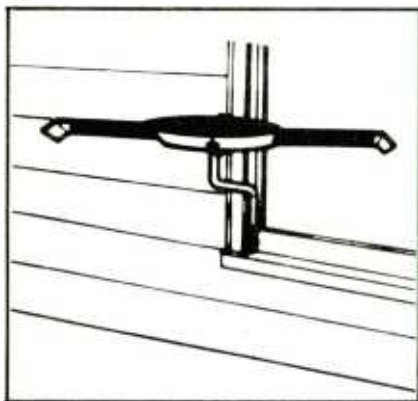

**Winegard**  
ANTENNA SYSTEMS

© Copyright, 1971  
U.S. patents pending

WINEGARD COMPANY • 3000 KIRKWOOD STREET • BURLINGTON, IOWA 52601

Circle 78 on reader service card